

**7504**

**A & B**

**PUMP ROTATION:**  
Clockwise: Firing Order: 1-5-3-6-2-4  
**DRIVE END:**  
R. H. Side  
**TIMED FOR PORT CLOSING**  
**SPECIAL FEATURES:**  
Standard Regulation, Parallel Fuel Adjustment,  
"Dual Speed"

**MACK**  
**APE 6BB 110T 7504A&B**



### SERVICE PARTS

Following are all parts, part numbers, pump codes and calibrations for the *Model: APE 6BB 110T 7504A&B*. The exploded view drawing below is detailed with part numbers

listed on the pages indicated. Refer to the Index Section for explanations of codes and abbreviations.

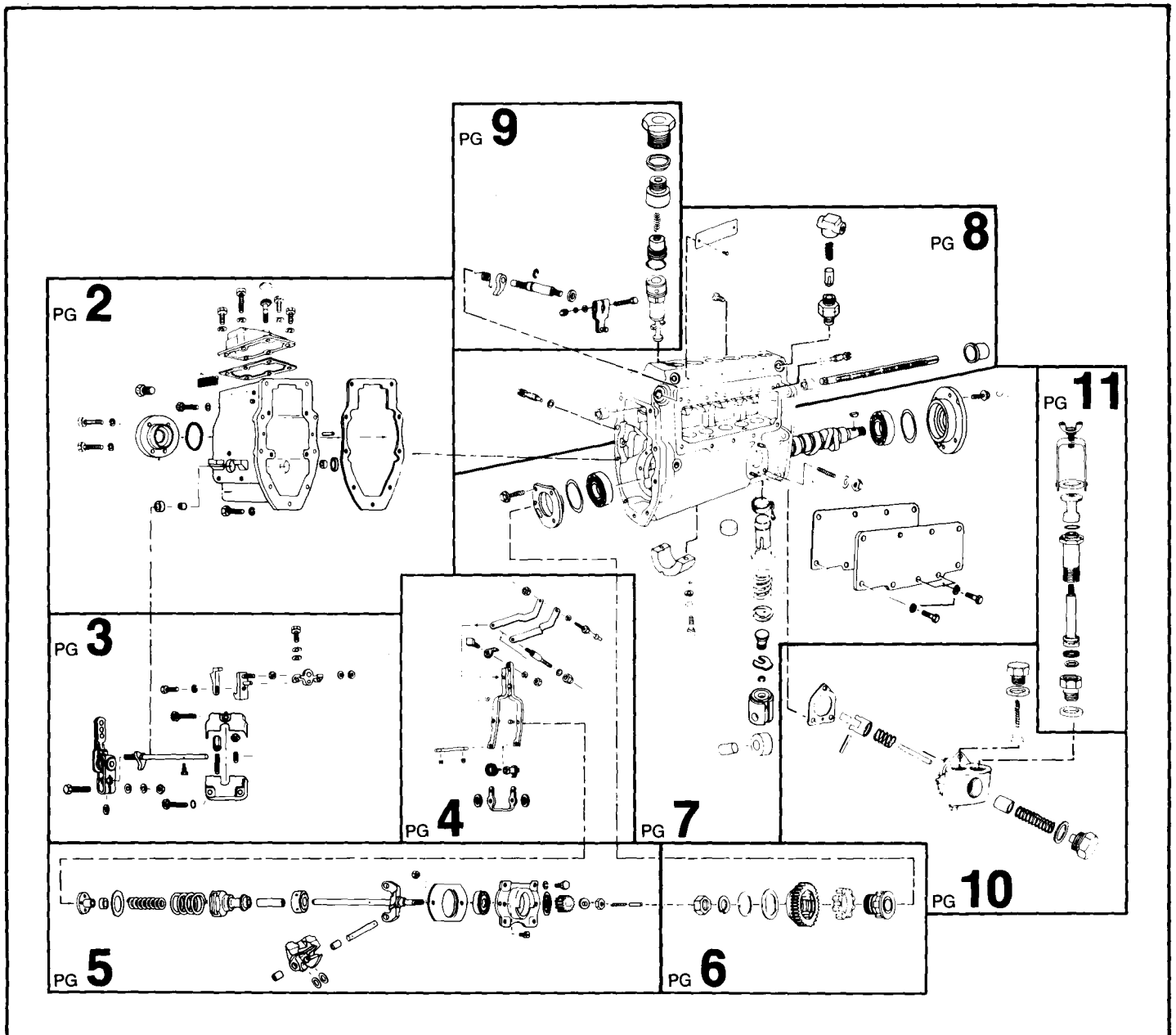

# MODEL APE 6BB 110T 7504A&B

**ASSY GVB/E 7505**  
GOVERNOR ASSY

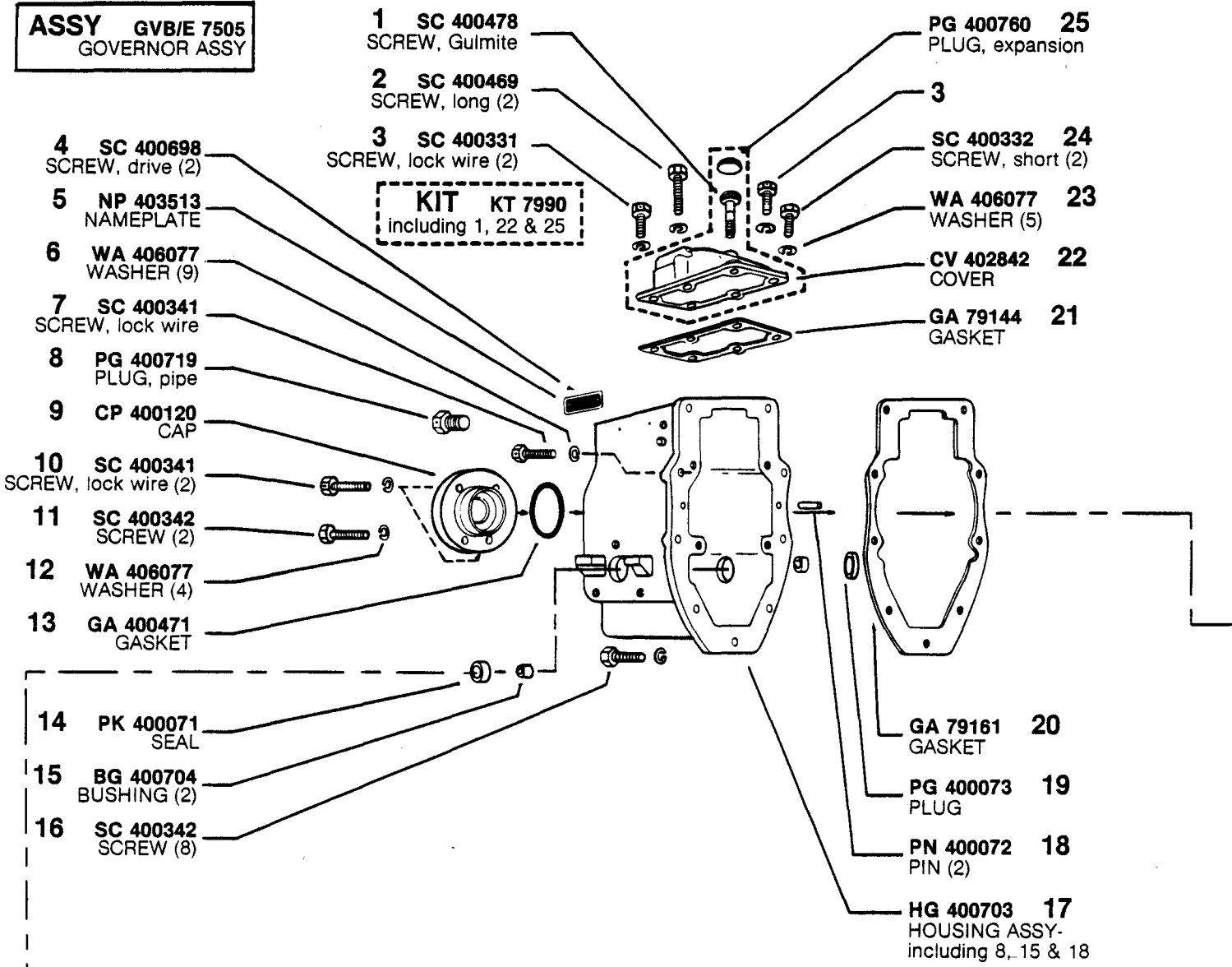

\*Quantity used is one, unless otherwise indicated in parenthesis ( ) following description of part.

**MODEL APE 6BB 110T 7504A&B**

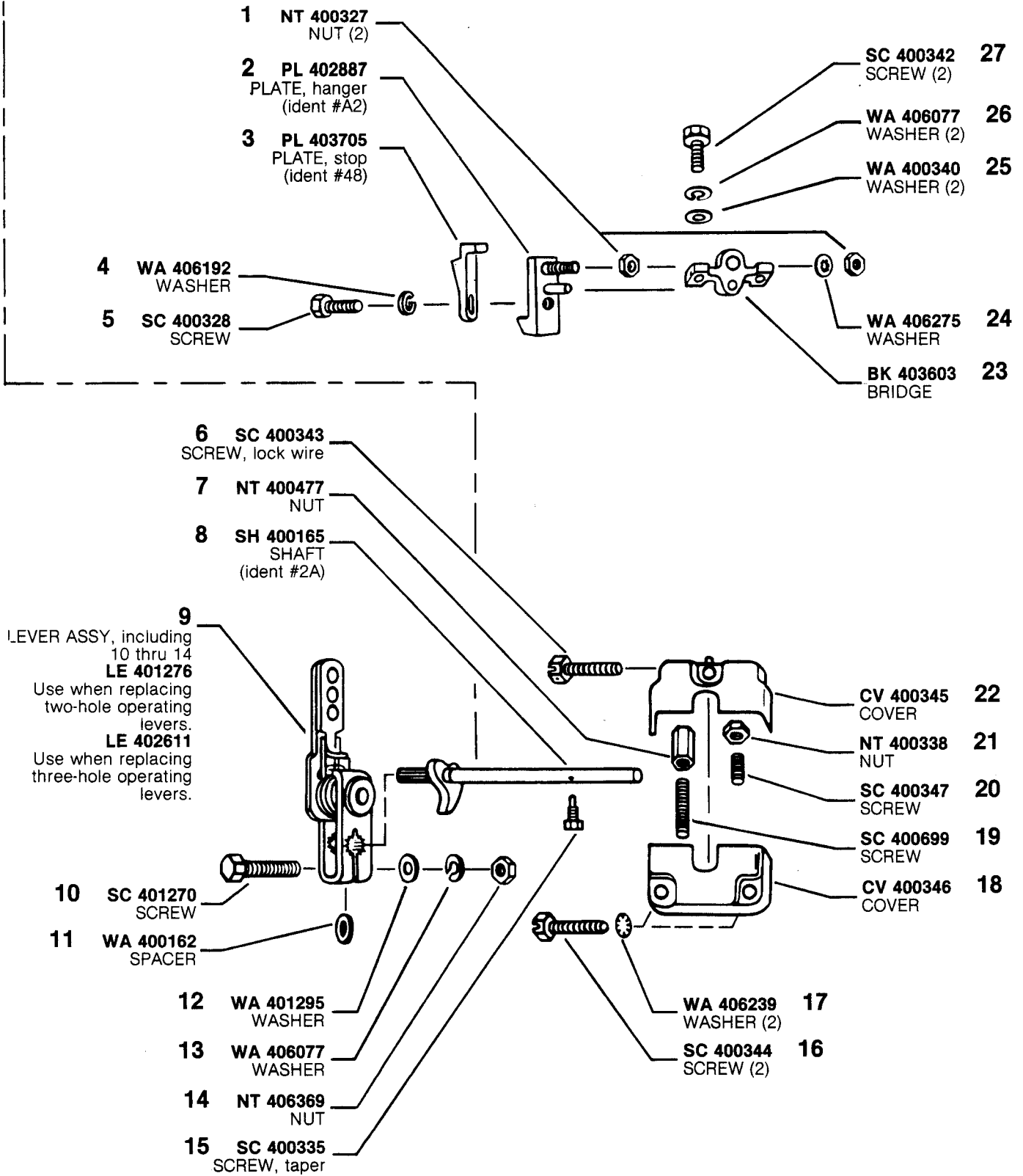

**MODEL APE 6BB 110T 7504A&B**

**ASSY LE 400782**  
LEVER ASSY, fulcrum-  
including 1, 2, 6 thru 8,  
10, 12 & 15 thru 20

**ASSY PL 400177**  
PLATE ASSY, including  
9 & 11

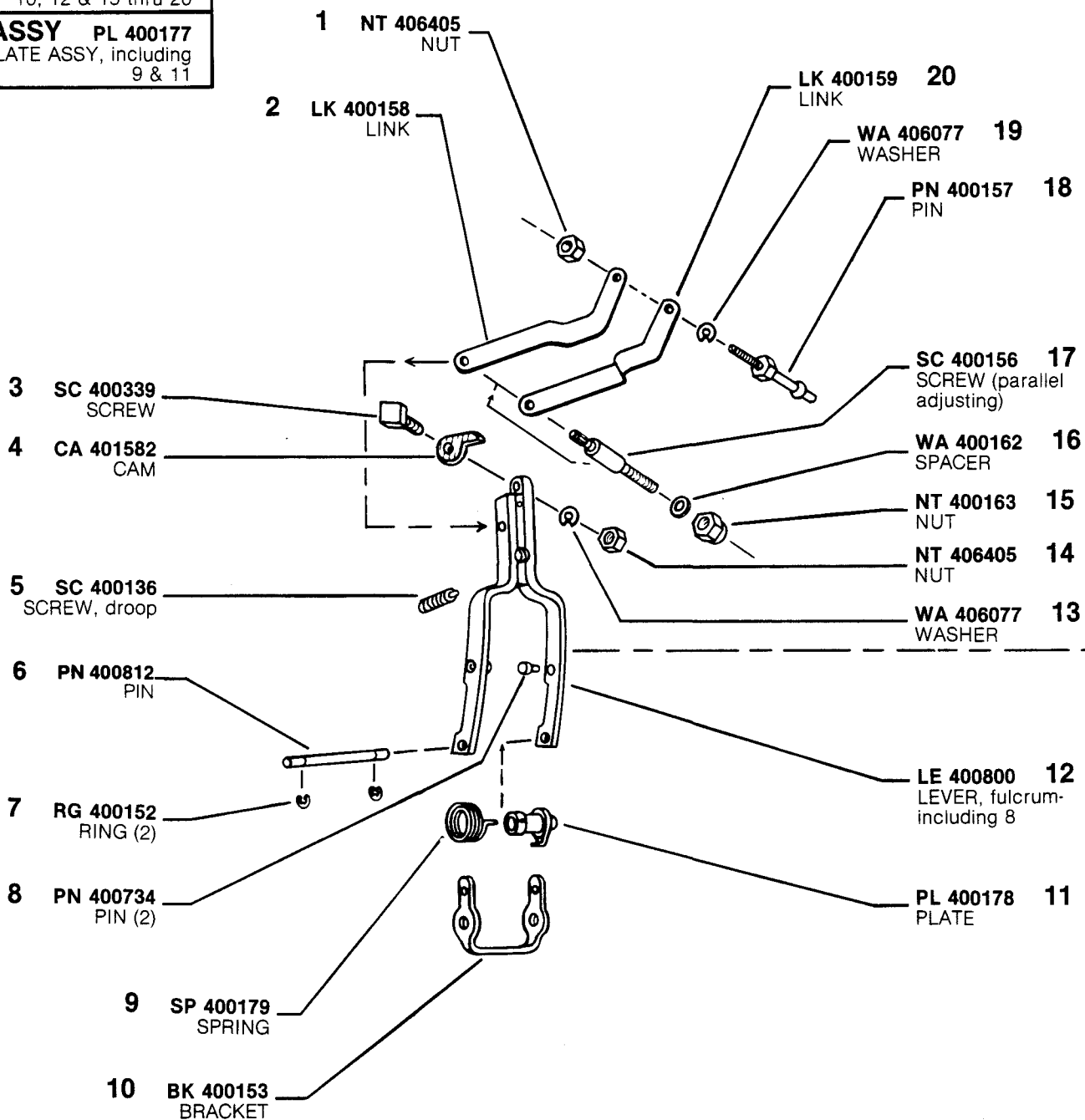

**MODEL APE 6BB 110T 7504A&B**

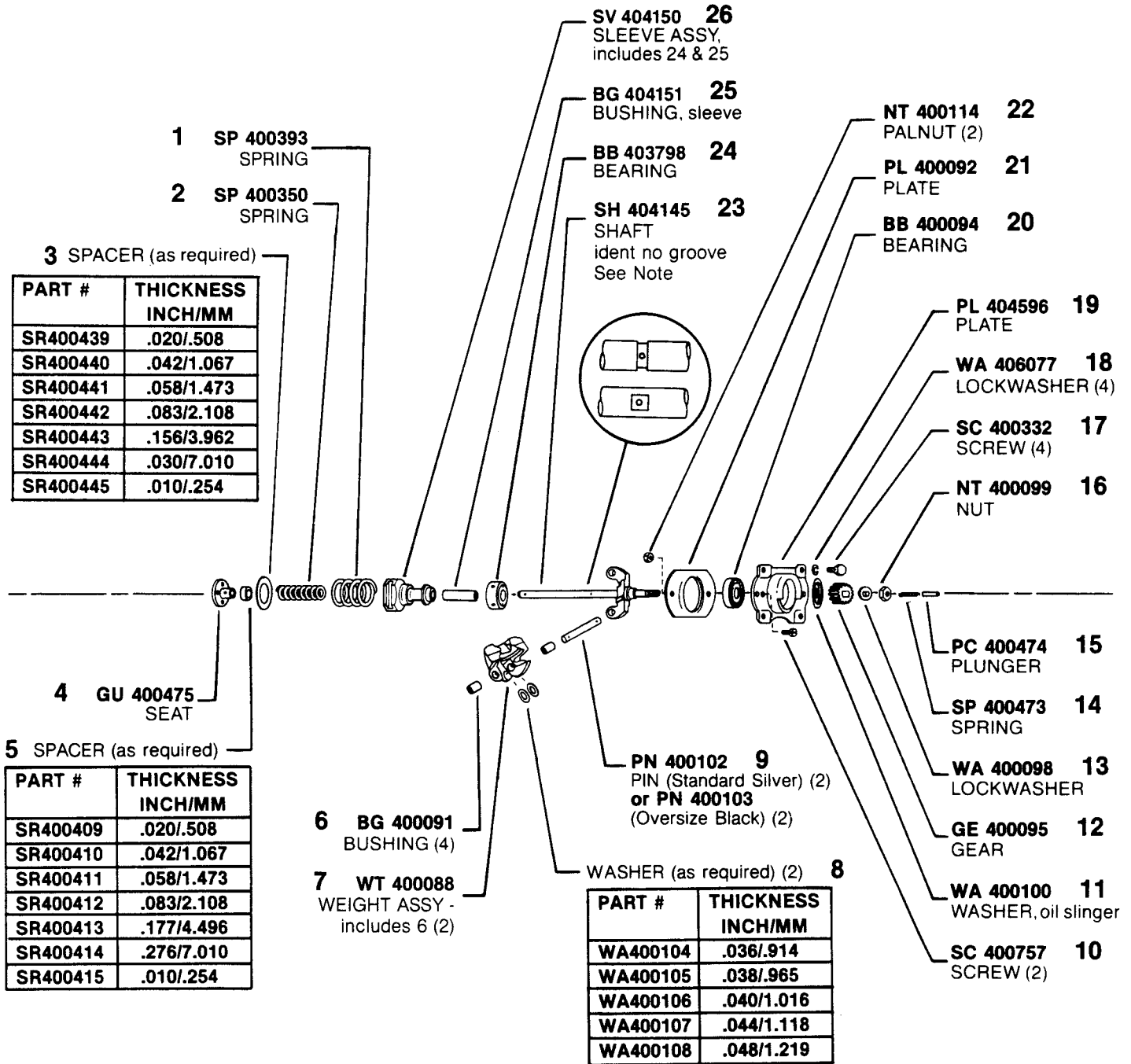

NOTE: When replacing shaft (#23 w/groove) with latest shaft (SH404145 no groove) BG404151 (25) MUST be used. Shaft with groove used BG400118.

# MODEL APE 6BB 110T 7504A&B

**ASSY GE 408663**  
**(RUBBER DRIVE)**  
DRIVE ASSY, includes  
3 thru 7

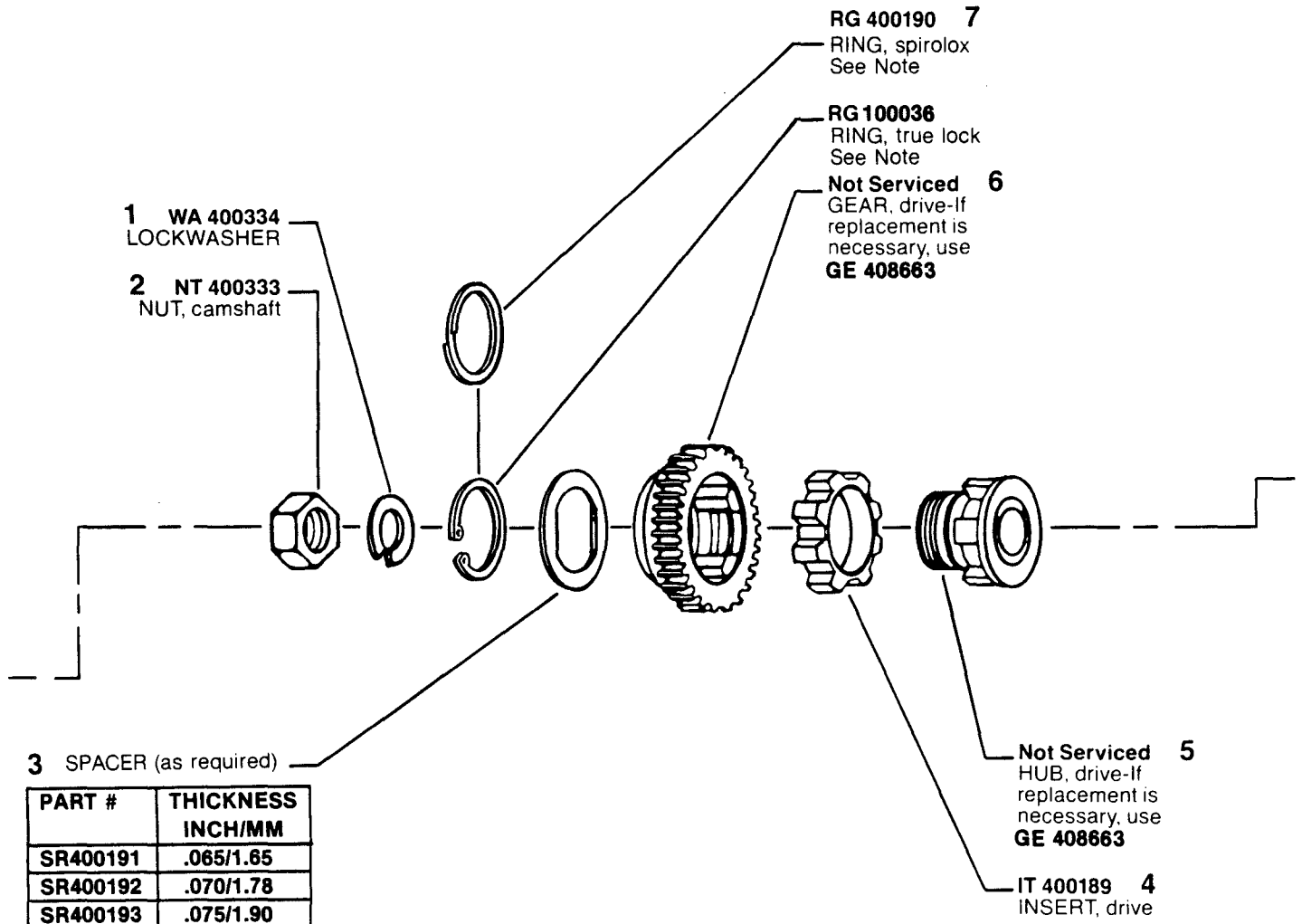

PART #	THICKNESS INCH/MM
SR400191	.065/1.65
SR400192	.070/1.78
SR400193	.075/1.90
SR400194	.080/2.03
SR400195	.085/2.16
SR400196	.0625/1.59
SR400197	.060/1.52
SR400198	.0675/1.71
SR400199	.0725/1.84
SR400200	.0775/1.97
SR400201	.0825/2.10
SR400202	.0875/2.22

#7 NOTE: Earlier rubber drive assy GE 400182 used RG 400190 (Spirolox ring), later assy GE 408663 using RG 100036 (true lock ring). Spirolox & true lock rings are NOT interchangeable.  
 [ASSY] NOTE: Pumps equipped with GE 7992A "Friction Clutch" refer to Service Instructions Model 6BBT Parts Bulletin P4 for Parts.

**MODEL APE 6BB 110T 7504A&B**

**ASSY TP 7651A**  
TAPPET ASSY-  
including 12-17 (6)

**ASSY HG 761246-1A**  
HOUSING ASSY-  
including 31; 4 on page  
8; and 8 thru 10, 17 &  
18 on page 9  
See note

**1 KY 403378**  
KEY, WOODRUFF  
(Earlier Camshafts  
require KY 764)

**2 SH 76121**  
CAMSHAFT  
See note

**3 SPACER (as required)**

PART #	THICKNESS INCH/MM
SR 7611-1	.008/0.2
SR 7611-2	.012/0.3
SR 7611-3	.016/0.4
SR 7611-4	.004/0.1
SR 7611-5	.006/0.15
SR 7611-6	.002/0.05
SR 7611-7	.032/0.8

**4 SC 403602**  
SCREW (4)

**5 PL 76117**  
PLATE

**6 (see note)**  
BEARING, center

**\*7 GA 5264**  
GASKET (2)

**8 WA 1518**  
WASHER (2)

**9 WA 406006**  
LOCKWASHER (2)

**10 SC 400064**  
SCREW (2)

**11 PG 7669**  
PLUG (6)

**12 KN 7610**  
KNOB (6)

**13 SPACER**  
(as required)

PART #	THICKNESS INCH/MM
SR 7610-1	.050/1.270
SR 7610-2	.054/1.372
SR 7610-3	.058/1.473
SR 7610-4	.062/1.575
SR 7610-5	.066/1.676
SR 7610-6	.046/1.168
SR 7610-7	.048/1.219
SR 7610-8	.052/1.321

PART #	THICKNESS INCH/MM
SR 7610-9	.056/1.422
SR 7610-10	.060/1.524
SR 7610-11	.064/1.626
SR 7610-15	.042/1.067
SR 7610-16	.044/1.118
SR 7610-17	.068/1.727
SR 7610-18	.072/1.829

**RL 7613A** **15**  
ROLLER (6)

**PN 7648** **14**  
PIN (6)

**RB 1004** **35**  
BEARING (2)

**PL 76113** **34**  
PLATE

**SC 400331** **33**  
SCREW (3)

**WI 763** **32**  
WIRE

**SD 400005** **31**  
STUD (3)

**WA 406077** **30**  
LOCKWASHER (3)

**NT 400555** **29**  
NUT (3)

**GA 76309** **\*28**  
GASKET

**CV 76312** **27**  
COVER

**WA 406077** **26**  
WASHER (9)

**SC 1865** **25**  
SCREW,  
wire seal (2)

**SC 1863** **24**  
SCREW (7)

**GE 400643** **23**  
GEAR (6)

**SC 400486** **22**  
SCREW, gear (6)

**SV 7671** **21**  
SLEEVE (6)

**GU 400510** **20**  
SEAT (6)

**SP 76149** **19**  
SPRING (6)

**GU 402592** **18**  
SEAT (6)

**RG 7618** **17**  
RING, snap (6)

**GU 76159** **16**  
SHELL (6)

NOTE: Latest pump housings and camshafts do not allow use of center bearing. If bearing is not to be used, refer to note on page 13 (PG 400760 information)

# MODEL APE 6BB 110T 7504A&B

\*Denotes parts included in "Pump & Governor Repair Gasket Kit" KT 76399-2.

**ASSY VA 400683**  
VALVE ASSY, overflow-  
including 11 thru 14

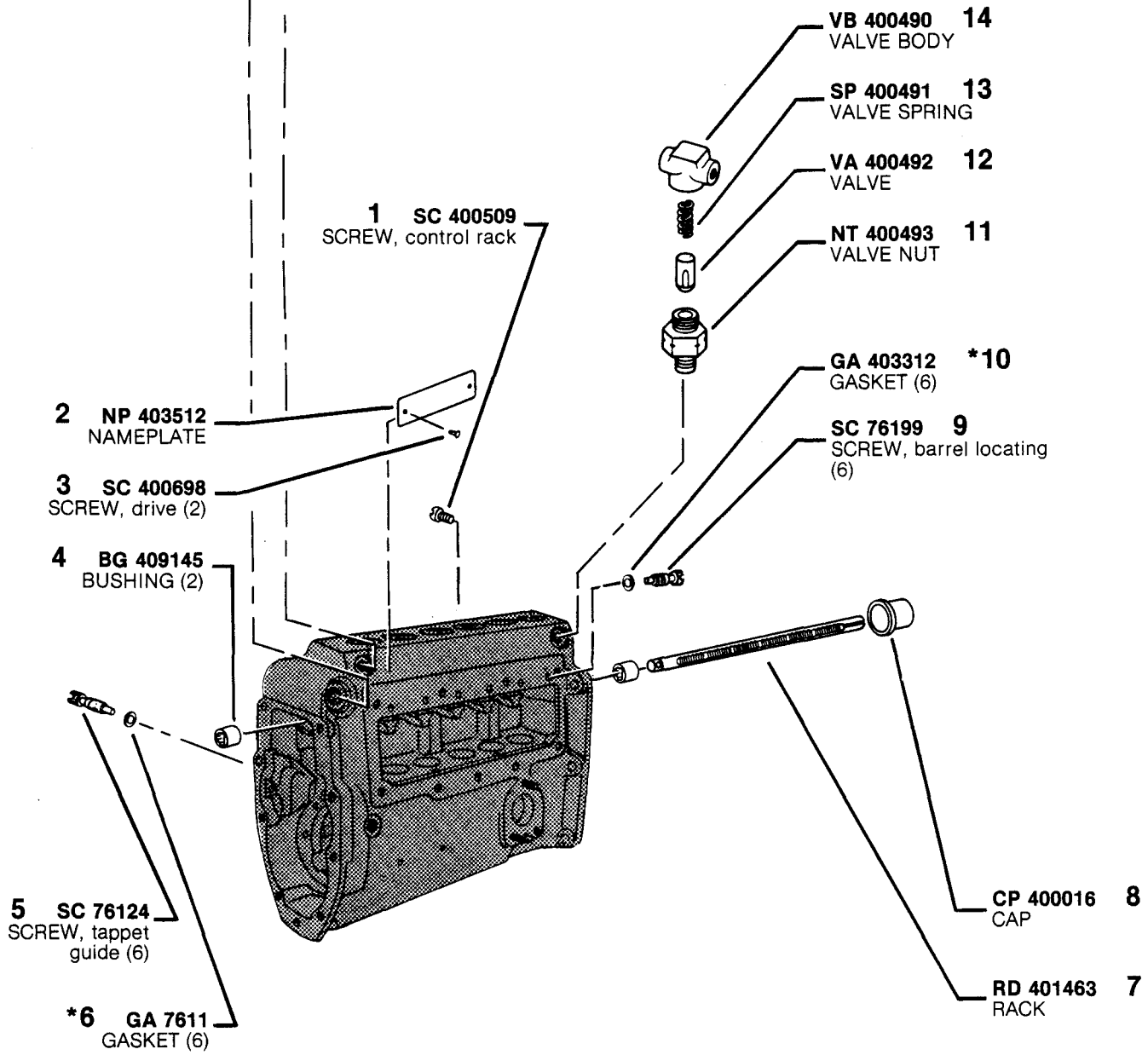

\*Denotes parts included in "Pump & Governor Repair Gasket Kit" KT 76399-2.

**MODEL APE 6BB 110T 7504A&B**

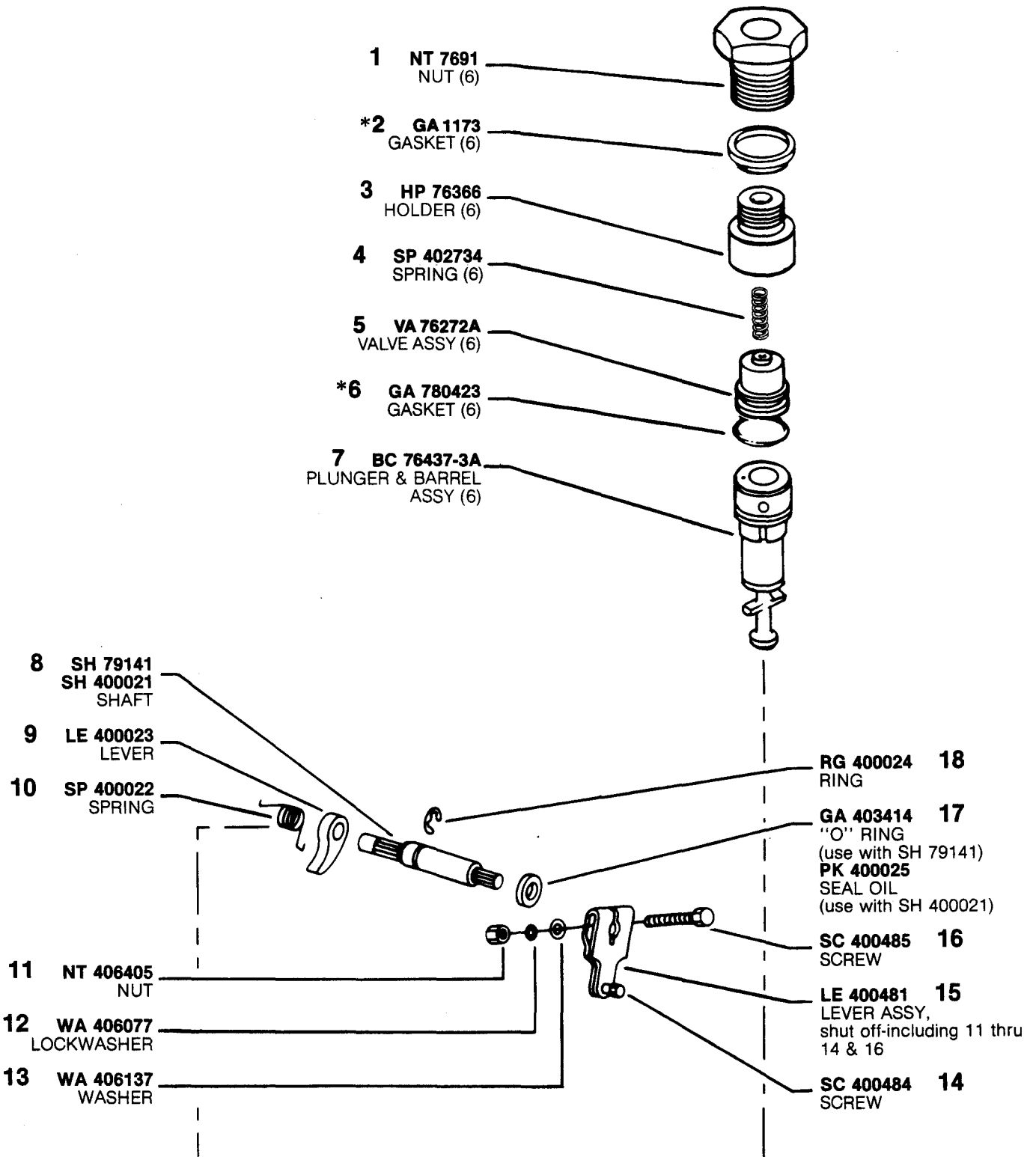

\*Denotes parts included in "Pump & Governor Repair Gasket Kit" KT 76399-2.

# MODEL APE 6BB 110T 7504A&B

**ASSY SPA 22B2**  
 PUMP ASSY, supply-  
 including 1 thru 9 & 11  
 thru 16

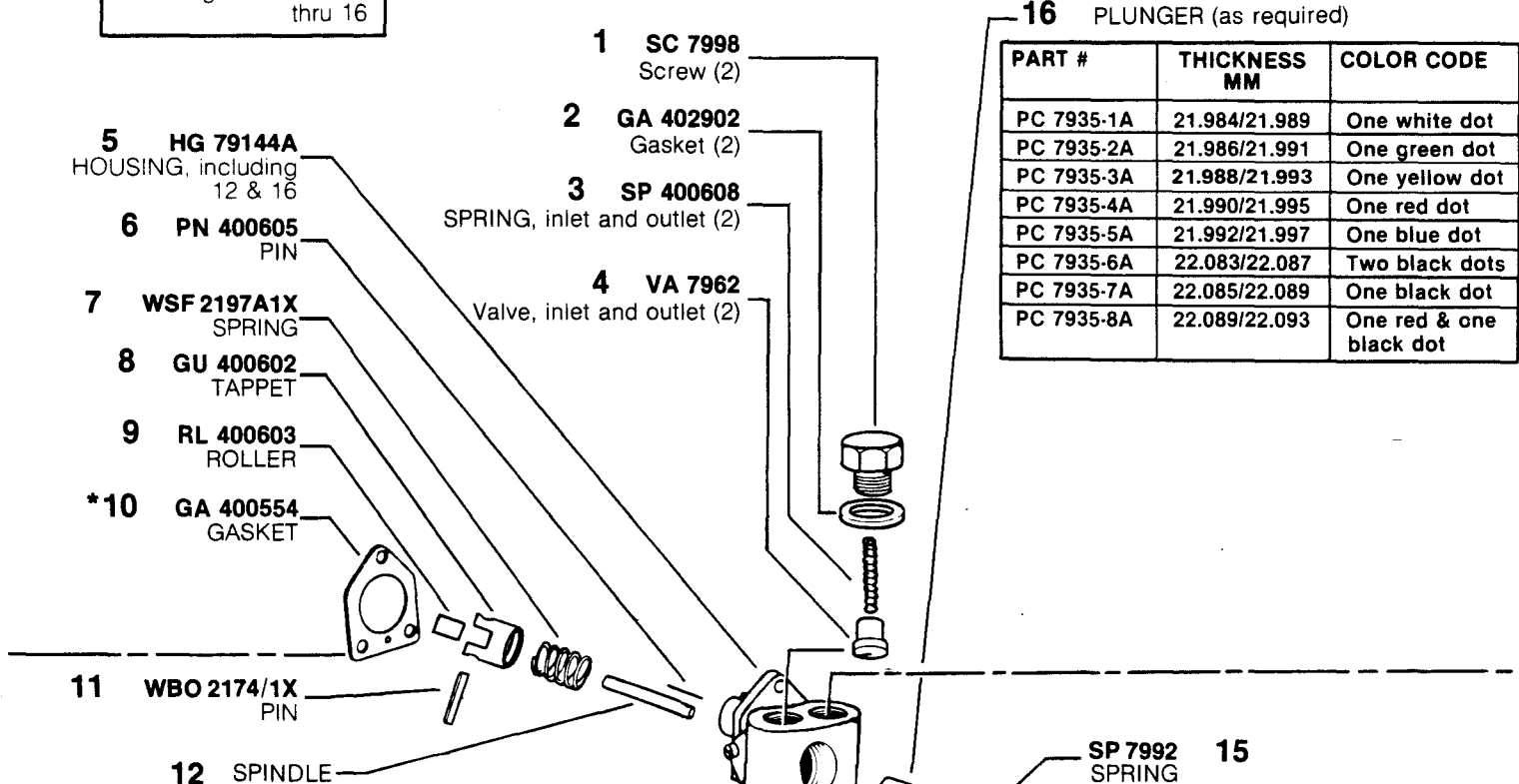

PART #	THICKNESS MM	COLOR CODE
PC 7935-1A	21.984/21.989	One white dot
PC 7935-2A	21.986/21.991	One green dot
PC 7935-3A	21.988/21.993	One yellow dot
PC 7935-4A	21.990/21.995	One red dot
PC 7935-5A	21.992/21.997	One blue dot
PC 7935-6A	22.083/22.087	Two black dots
PC 7935-7A	22.085/22.089	One black dot
PC 7935-8A	22.089/22.093	One red & one black dot

PART #	THICKNESS MM	COLOR CODE
SL 798-1	4.993/4.995	Red — one end
SL 798-2	4.995/4.997	Blue — one end
SL 798-3	4.997/4.999	Yellow — one end
SL 795-1	5.020/5.022	Yellow — one end White — one end
SL 795-2	5.044/5.046	Yellow — one end Black — one end
SL 795-3	5.067/5.069	White — one end Black — one end
SL 798-4	5.087/5.089	White — one end
SL 798-5	5.089/5.091	Black — one end
SL 798-6	5.091/5.093	Green — one end
SL 798-7	5.093/5.095	Aluminum — one end
SL 795-4	5.116/5.118	Aluminum — one end Red — one end
SL 795-5	5.039/5.141	Aluminum — one end Blue — one end
SL 795-6	5.162/5.164	Aluminum — one end Yellow — one end
SL 798-8	5.189/5.191	Red — both ends
SL 798-9	5.191/5.193	Blue — both ends
SL 798-10	5.193/5.195	Yellow — both end
SL 798-11	5.195/5.197	Black — both ends

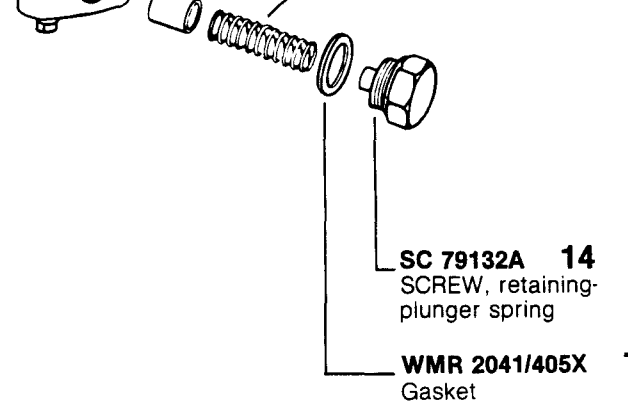

SPINDLE (requires reaming)

PART #	THICKNESS MM	COLOR CODE
SL 793-1	5.557/5.560	Red & Blue — one end
SL 793-2	5.561/5.564	Red & Green — one end
SL 793-3	5.565/5.568	Red & Yellow — one end
SL 793-4	5.569/5.572	Blue & Green — one end

# MODEL APE 6BB 110T 7504A&B

**ASSY MP 404760**  
MANUAL PRIMER  
ASSY, including 3 thru 9  
(Optional)

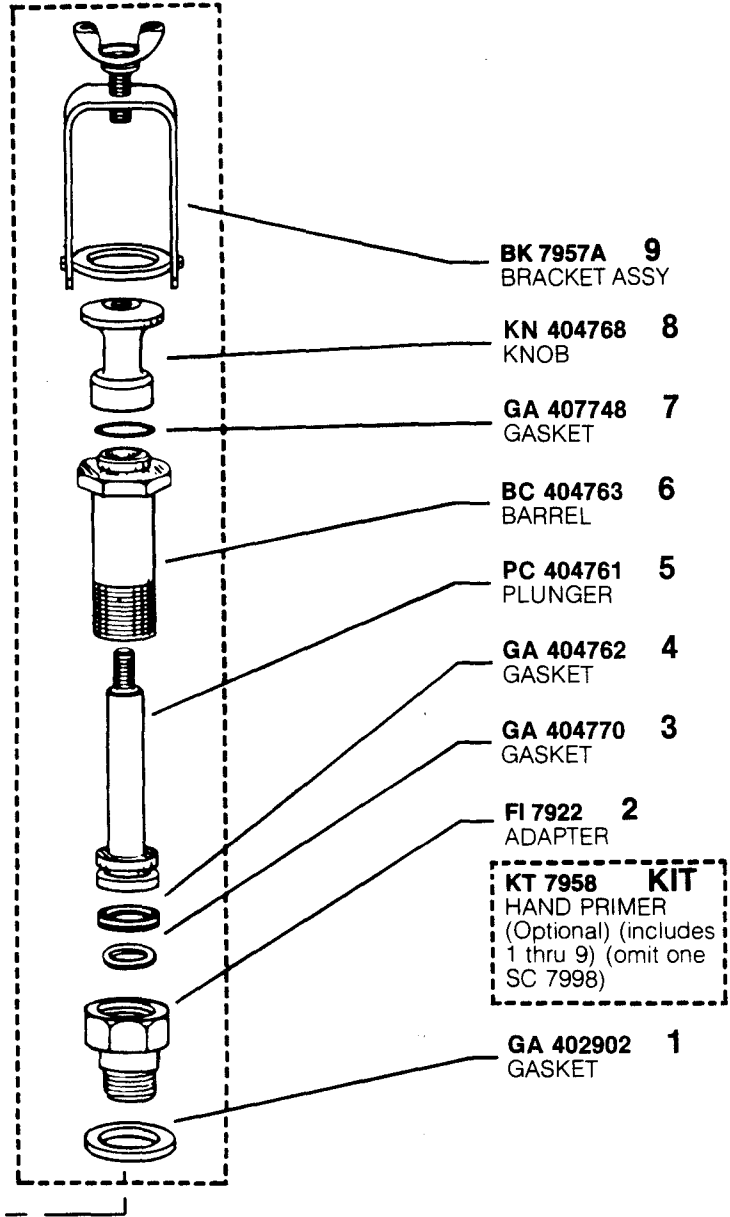

**BK 7957A 9**  
BRACKET ASSY

**KN 404768 8**  
KNOB

**GA 407748 7**  
GASKET

**BC 404763 6**  
BARREL

**PC 404761 5**  
PLUNGER

**GA 404762 4**  
GASKET

**GA 404770 3**  
GASKET

**FI 7922 2**  
ADAPTER

**KT 7958 KIT**  
HAND PRIMER  
(Optional) (includes  
1 thru 9) (omit one  
SC 7998)

**GA 402902 1**  
GASKET

**MODEL APE 6BB 110T 7504A&B**

### CALIBRATION SET-UP

Engine Holders ..... HSN 780050  
 Opening Pressure ..... 4200-4350 psi  
 Engine Nozzles ..... NBM770012  
 Engine Nozzle & Holder Assy .... Ref. #NHM780002  
 High Pressure Tubing ..... 1/4" OD x .067" ID  
 x 39" Long

Calibrating Oil ..... Viscor 1487C @ 100°-105°F  
 (38-41°C) at pump inlet  
 Lube Oil ..... SAE #20 or #30 at 20 psi/1.4 bar  
**PROCEDURE** ..... Refer to the Service Instructions  
 and use figures below

### 7504A&B CODE 1 DATA

Engine Model ..... EM6-250R  
 Engine Static Timing ..... 23°  
 Customer No. .... 313GC5152-P16  
 Kit No. .... KT76517-1  
 Customer Kit. No. .... 313GC5152-P15  
 Governor Speeds ..... 250/1050  
 Cam Nose Angle ..... 89°(± 2°)

Governor Outer Spring  
 Precompression ..... Flush to 0.5mm (.020")  
 Governor Inner Spring Gap .3.75-4.00mm(.148"-.157")  
 Lift to Port Closing ..... 3.00-3.20mm  
 (.118"-.126"), cam lift with control rack at  
 approximate mid-travel position

STEP	A	B	C	D
	Full Load at 1.135" Rack Ext	Cam Departure	Peak Torque (from actual A delivery)	Droop Screw (from actual A delivery)
RPM	1050	1080	700	630
DEL cc/500 str	71.0-75.0	NONE	+ 17.0 ± 2.5	+ 22.0 ± 2.5
DEL cc/300 str	42.5-45.0	NONE	+ 10.0 ± 1.5	+ 13.0 ± 1.5

STEP	E	F	G
	"PLE"	Low Idle	Minimum Delivery
RPM	800	300	75
DEL cc/500 str	59.0-63.0	12-14	—
DEL cc/300 str	35.5-38.0	7- 8.5	—
DEL cc/100 str	—	—	12.0

**SERVICE CHECK** — A, C & D are applicable.

Calibration data consists of latest calibration figures. Earlier editions may require changing parts to meet calibration requirements. See record of change chart.

### RECORD OF CHANGE

EDITION	SPRING INNER
A	8512-11
B	8512-2

## **NOTE ON ELIMINATION OF CENTER BEARING IN APE 6BB FUEL INJECTION PUMPS**

### **INFORMATION:**

Latest APE 6BB fuel injection pumps do not incorporate center bearings and accordingly, pump housings and cam shafts are no longer machined to provide for use of the part.

For earlier type APE 6BB pumps, elimination of the center bearing is **OPTIONAL**.

**CAUTION:** Prior to assembly of a camshaft and center bearing to a pump, first determine that the bearing can physically be used. Insure that there are holes in the housing for the bearing retaining screws and that the journal between cam lobes #3 and #4 has been machined to accept the part.

If a housing has been machined to accept a center bearing and the bearing is not to be utilized, then the screw holes must be plugged per the following instructions:

### **INSTRUCTIONS:**

Plug center bearing screw holes as follows:

1. Clean out screw hole counterbores.
2. Press plug, PG 400760 into each hole.
3. Seal plug in hole with Devcon F, or an equivalent epoxy.

**NOTE:** Elimination of the center bearing is only to be undertaken if the initial service problem required removal of the camshaft from the pump.

**THIS NOTE SUPERCEEDS MODEL 6BBT, SERVICE BULLETIN S7.**

---

# MODEL APE 6BB 110T 7504A&B