

7512

A & B

PUMP ROTATION:
Clockwise: Firing Order: 1-5-3-6-2-4
DRIVE END:
R. H. Side

TIMED FOR PORT CLOSING

SPECIAL FEATURES:
Standard Regulation, Parallel Fuel Adjustment
Dual Speed

MACK
APE 6BB 110T 7512A&B



SERVICE PARTS

Following are all parts, part numbers, pump codes and calibrations for the *Model: APE 6BB 110T 7512A&B*. The exploded view drawing below is detailed with part numbers

listed on the pages indicated. Refer to the Index Section for explanations of codes and abbreviations.

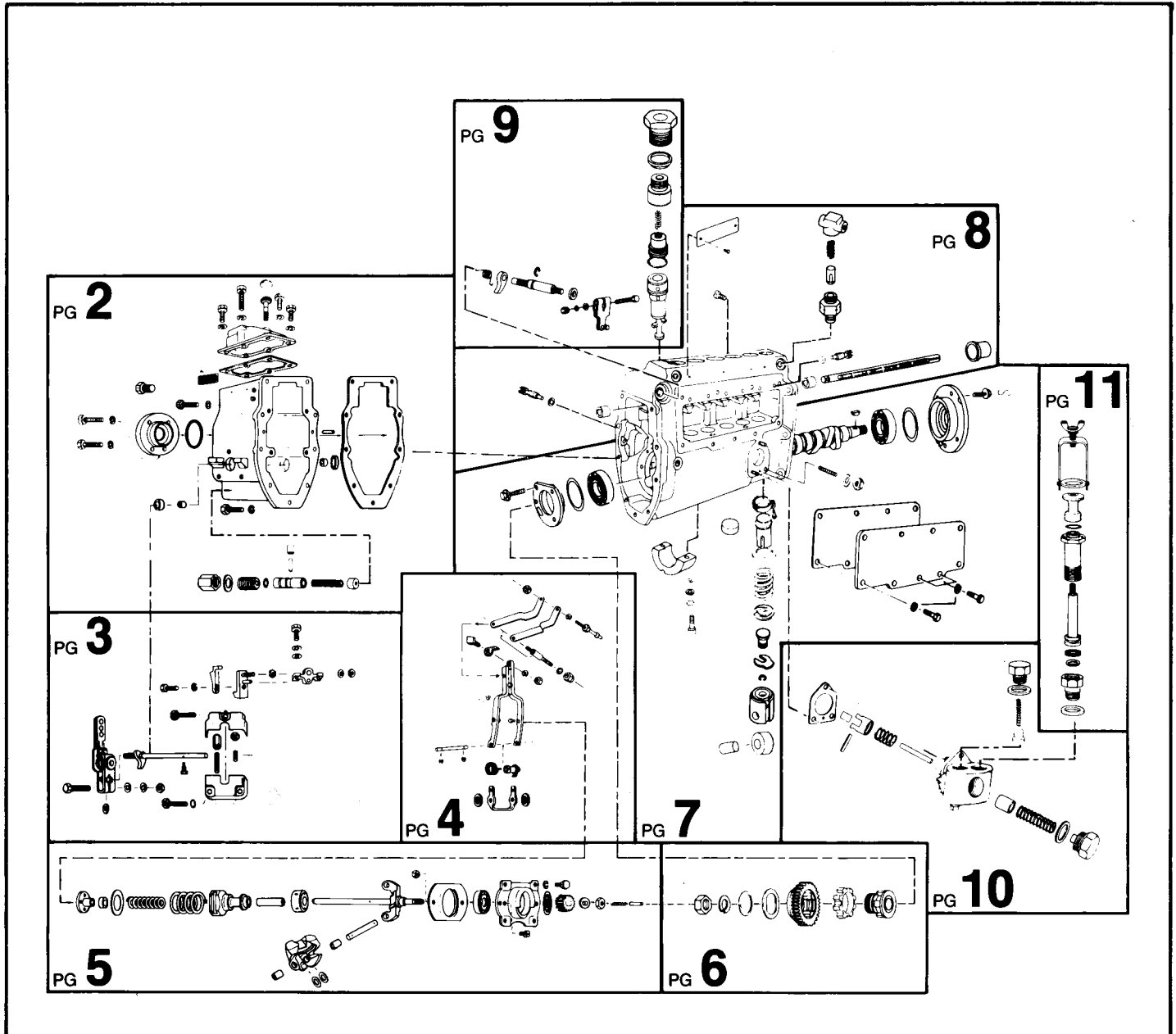

MODEL APE 6BB 110T 7512A&B

ASSY GVB/E 7513
GOVERNOR ASSY

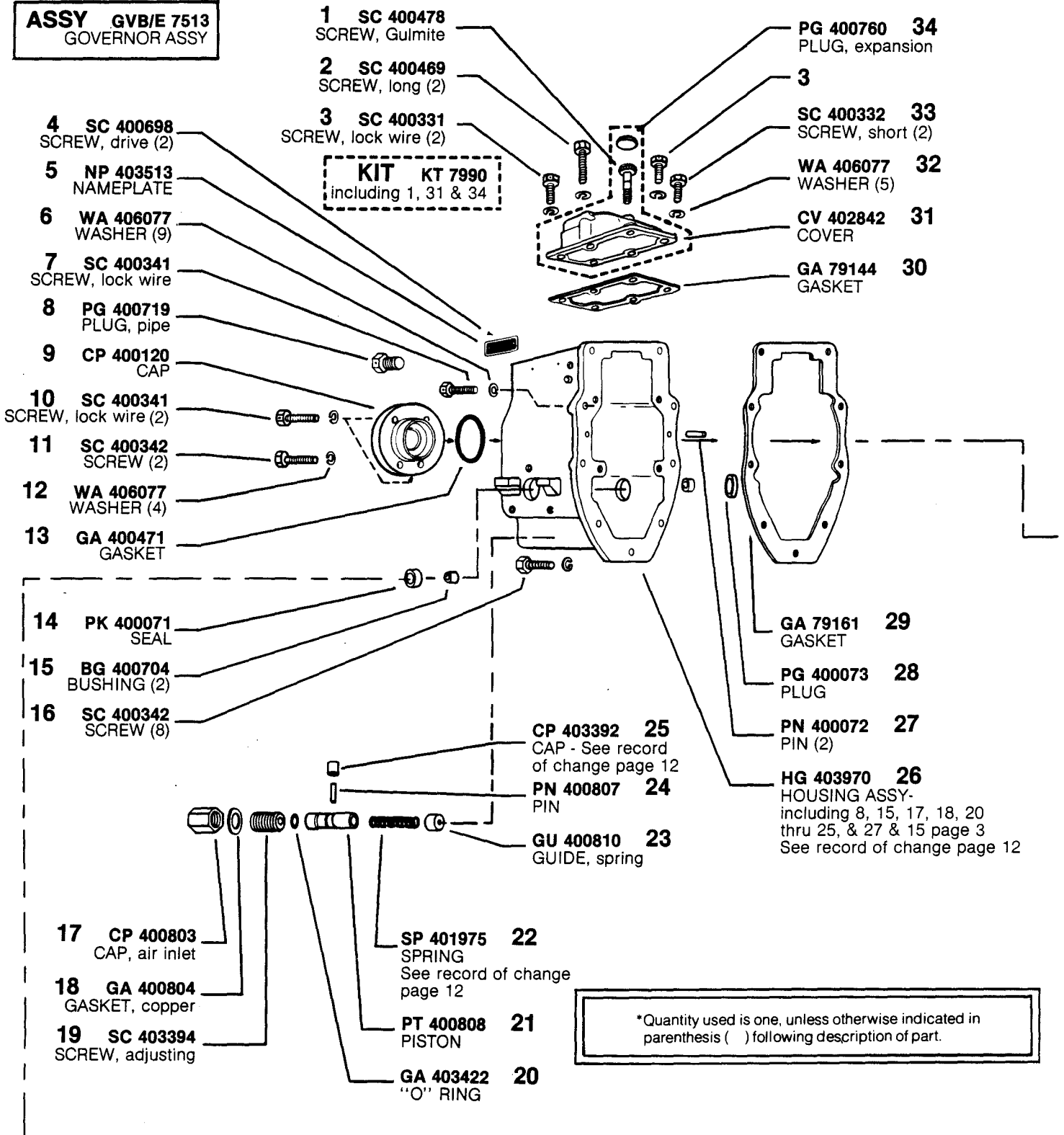

MODEL APE 6BB 110T 7512A&B

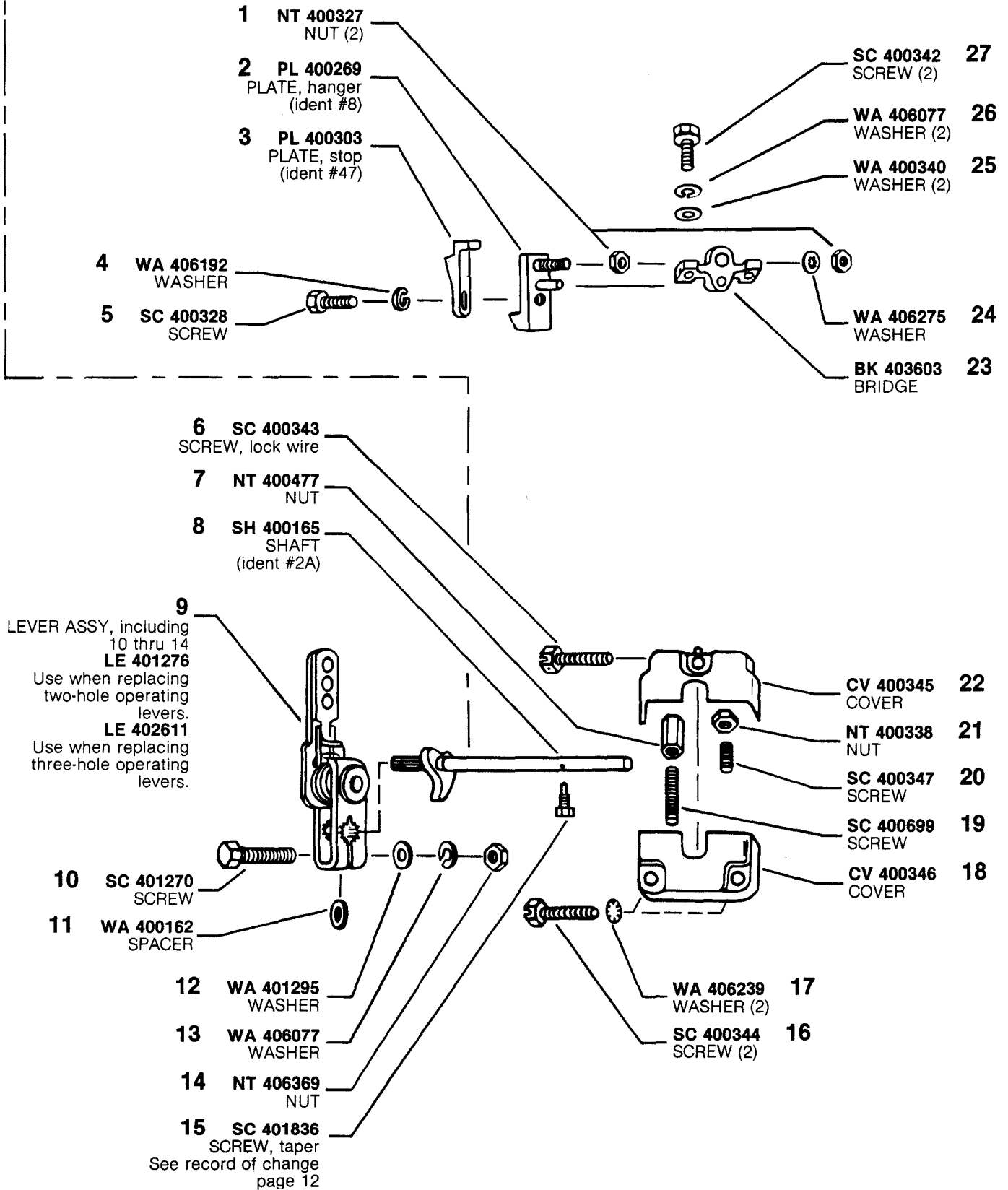

MODEL APE 6BB 110T 7512A&B

ASSY LE 400782
LEVER ASSY, fulcrum-
including 1, 2, 6 thru 8,
10, 12 & 15 thru 20

ASSY PL 400177
PLATE ASSY, including
9 & 11

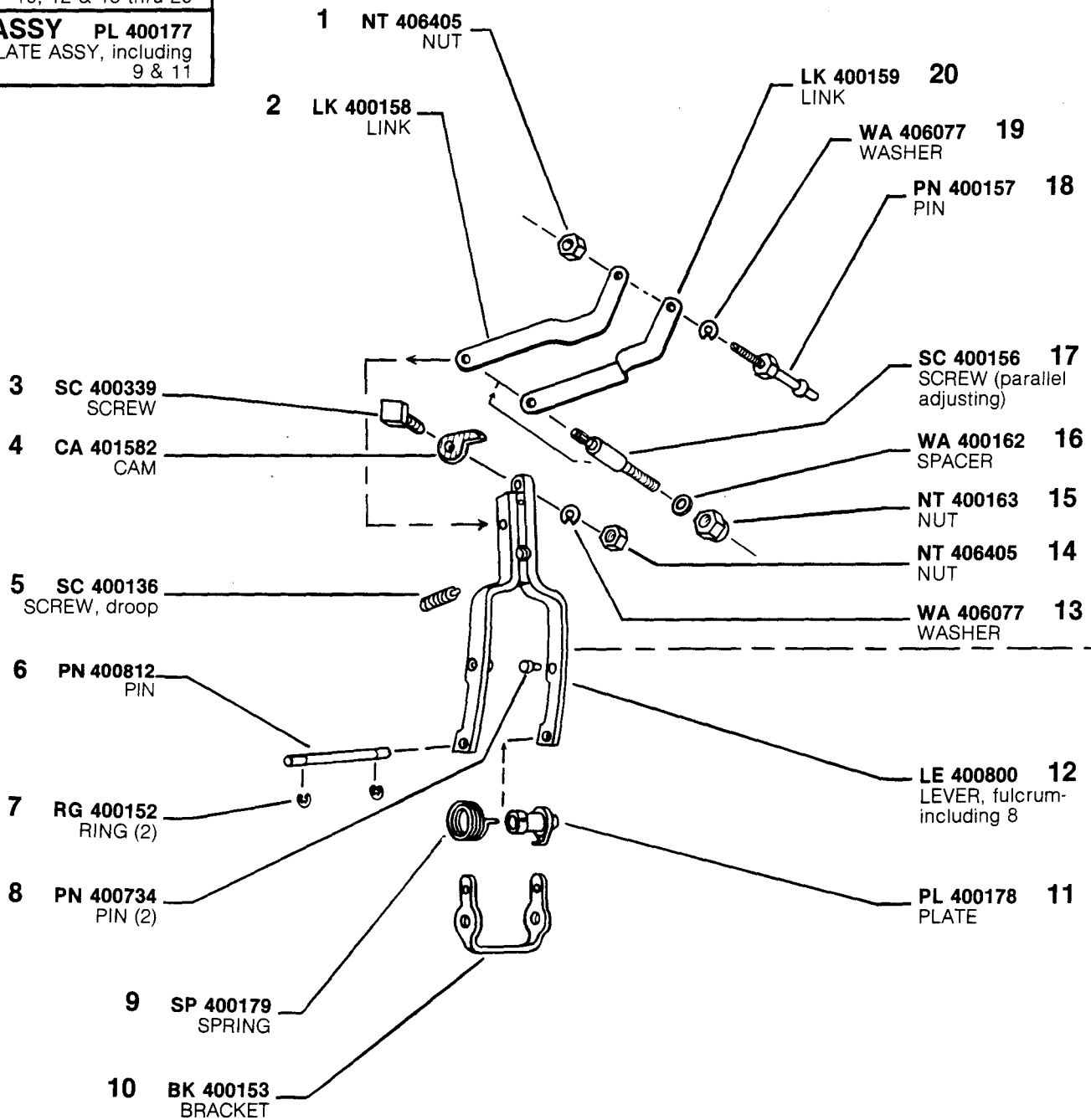

MODEL APE 6BB 110T 7512A&B

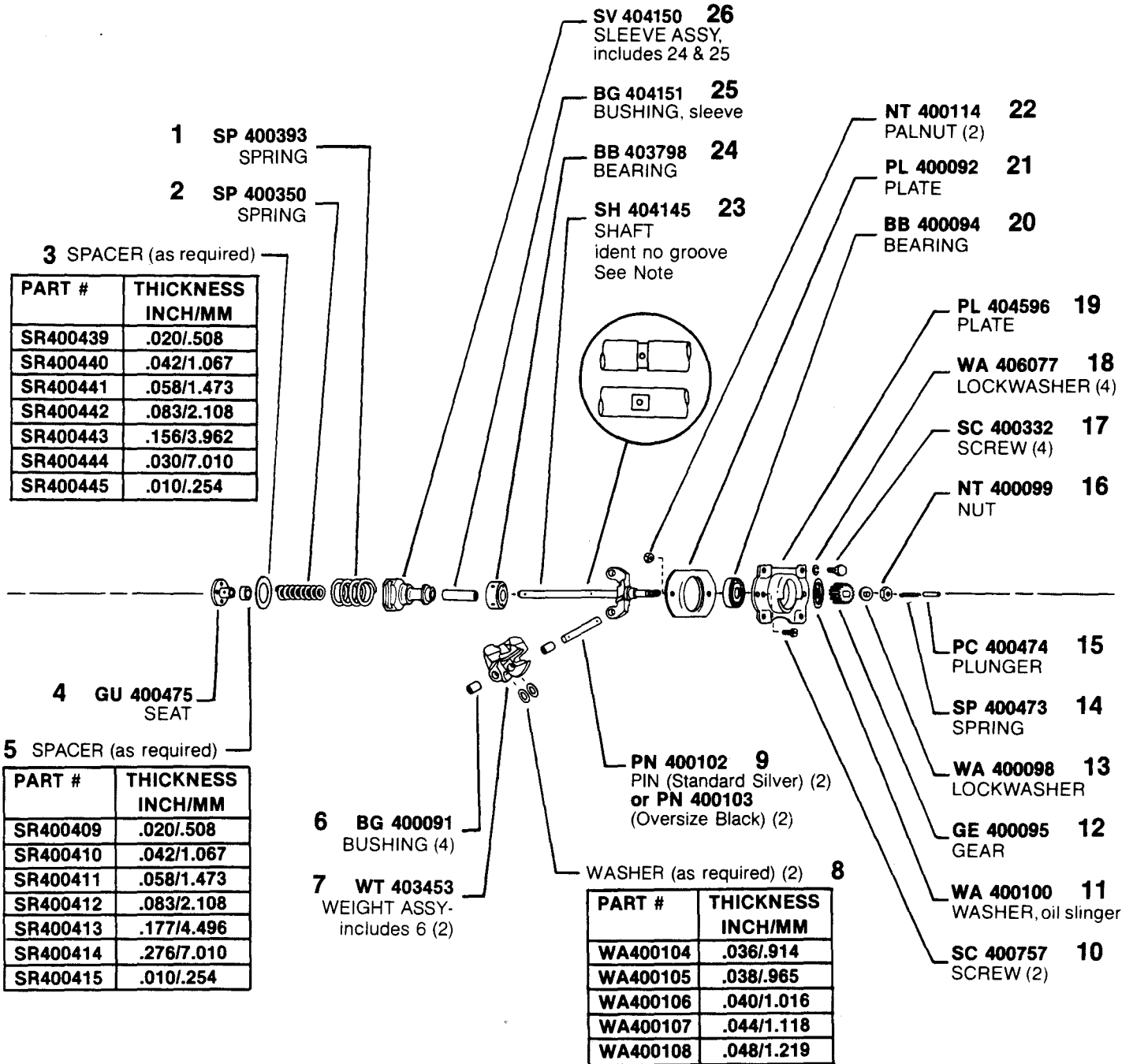

NOTE: When replacing shaft (#23 w/groove) with latest shaft (SH404145 no groove) BG404151 (25) MUST be used. Shaft with groove used BG400118.

MODEL APE 6BB 110T 7512A&B

ASSY GE 408663
(RUBBER DRIVE)
DRIVE ASSY, includes
3 thru 7

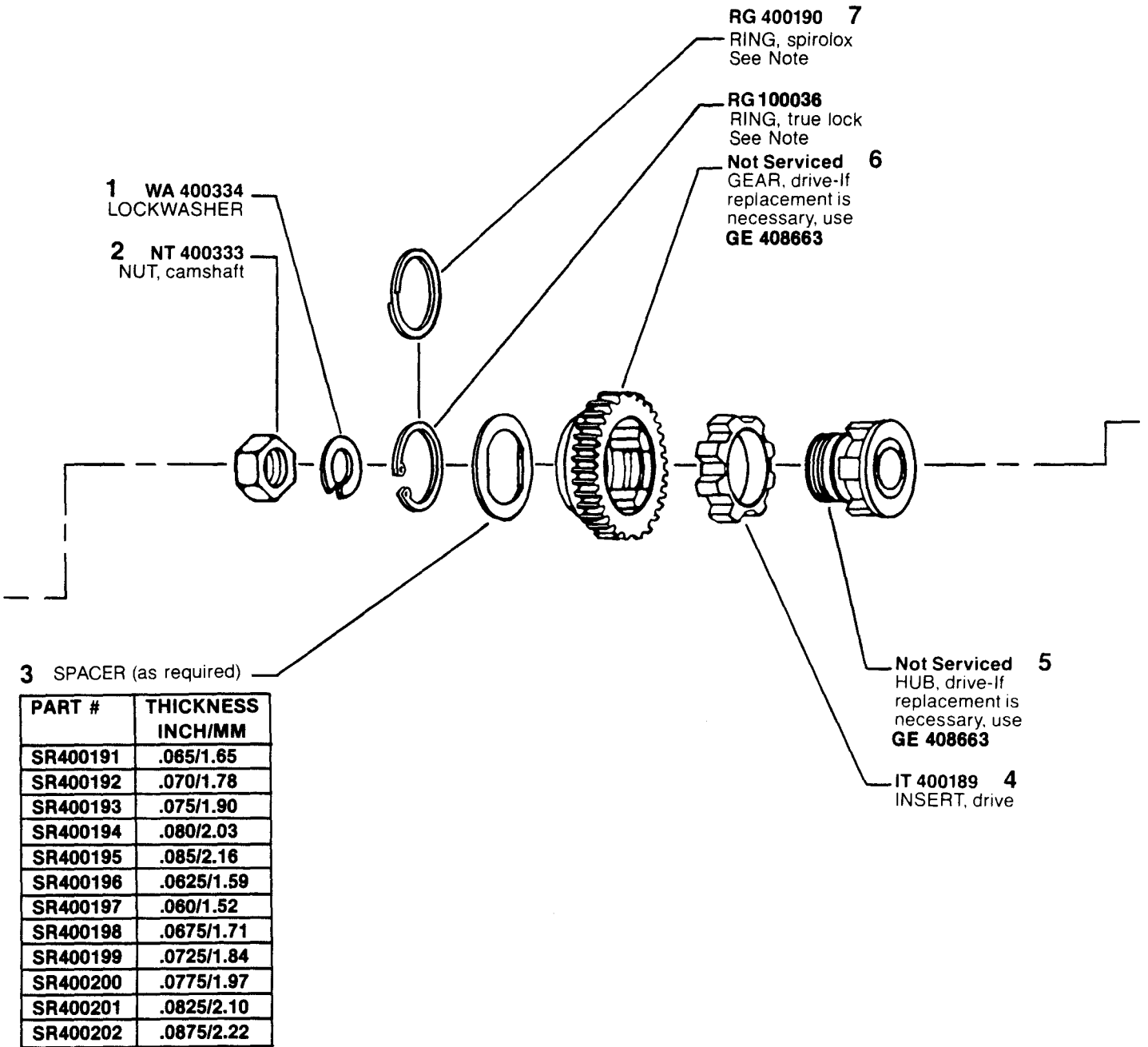

#7 NOTE: Earlier rubber drive assy GE 400182 used RG 400190 (Spirolox ring), later assy GE 408663 using RG 100036 (true lock ring). Spirolox & true lock rings are NOT interchangeable.

ASSY NOTE: Pumps equipped with GE 7992A "Friction Clutch" refer to Service Instructions Model 6BBT Parts Bulletin P4 for Parts.

MODEL APE 6BB 110T 7512A&B

ASSY TP 7651A
TAPPET ASSY-
including 12-17 (6)

ASSY HG 761246-1A
HOUSING ASSY-
including 31; 4 on page
8; and 8 thru 10, 17 &
18 on page 9
See note

3 SPACER (as required)

PART #	THICKNESS INCH/MM
SR 7611-1	.008/0.2
SR 7611-2	.012/0.3
SR 7611-3	.016/0.4
SR 7611-4	.004/0.1
SR 7611-5	.006/0.15
SR 7611-6	.002/0.05
SR 7611-7	.032/0.8

1 KY 403378
KEY, WOODRUFF
(Earlier Camshafts
require KY 764)

2 SH 76121
CAMSHAFT
See note

RB 1004 35
BEARING (2)

PL 76113 34
PLATE

SC 400331 33
SCREW (3)

WI 763 32
WIRE

SD 400005 31
STUD (3)

WA 406077 30
LOCKWASHER (3)

NT 400555 29
NUT (3)

GA 76309 *28
GASKET

CV 76312 27
COVER

WA 406077 26
WASHER (9)

SC 1865 25
SCREW,
wire seal (2)

SC 1863 24
SCREW (7)

GE 400643 23
GEAR (6)

SC 400486 22
SCREW, gear (6)

SV 7671 21
SLEEVE (6)

GU 400510 20
SEAT (6)

SP 76149 19
SPRING (6)

GU 402592 18
SEAT (6)

RG 7618 17
RING, snap (6)

GU 76159 16
SHELL (6)

RL 7613A 15
ROLLER (6)

PN 7648 14
PIN (6)

4 SC 403602
SCREW (4)

5 PL 76117
PLATE

6 (see note)
BEARING, center

***7** GA 5264
GASKET (2)

8 WA 1518
WASHER (2)

9 WA 406006
LOCKWASHER (2)

10 SC 400064
SCREW (2)

11 PG 7669
PLUG (6)

12 KN 7610
KNOB (6)

13 SPACER
(as required)

PART #	THICKNESS INCH/MM
SR 7610-1	.050/1.270
SR 7610-2	.054/1.372
SR 7610-3	.058/1.473
SR 7610-4	.062/1.575
SR 7610-5	.066/1.676
SR 7610-6	.046/1.168
SR 7610-7	.048/1.219
SR 7610-8	.052/1.321

PART #	THICKNESS INCH/MM
SR 7610-9	.056/1.422
SR 7610-10	.060/1.524
SR 7610-11	.064/1.626
SR 7610-15	.042/1.067
SR 7610-16	.044/1.118
SR 7610-17	.068/1.727
SR 7610-18	.072/1.829

NOTE: Latest pump housings and camshafts do not allow use of center bearing. If bearing is not to be used, refer to note on page 13 (PG 400760 information)

MODEL APE 6BB 110T 7512A&B

*Denotes parts included in "Pump & Governor Repair Gasket Kit" KT 76399-2.

ASSY VA 400683
VALVE ASSY, overflow-
including 11 thru 14

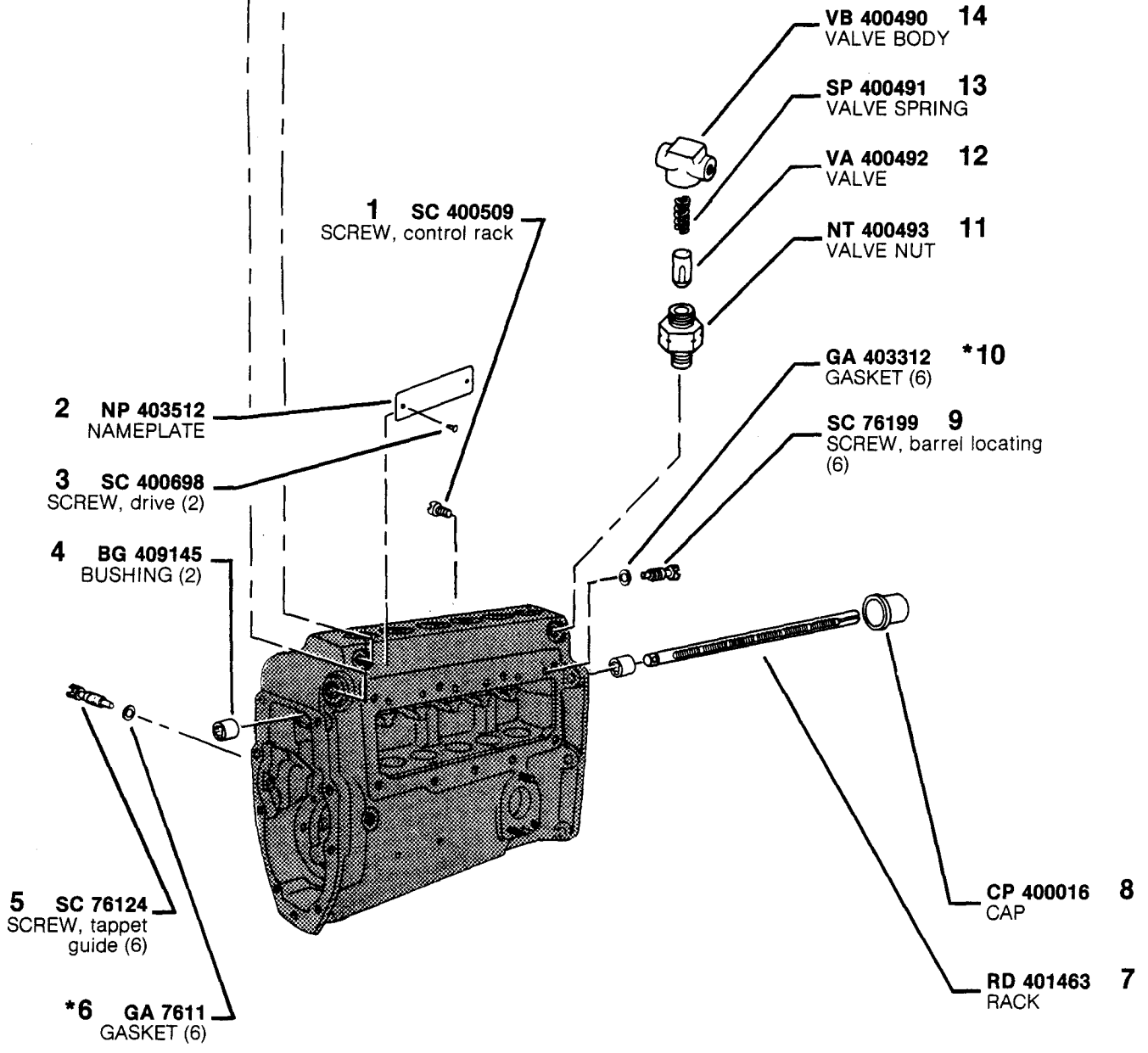

*Denotes parts included in "Pump & Governor Repair Gasket Kit" KT 76399-2.

MODEL APE 6BB 110T 7512A&B

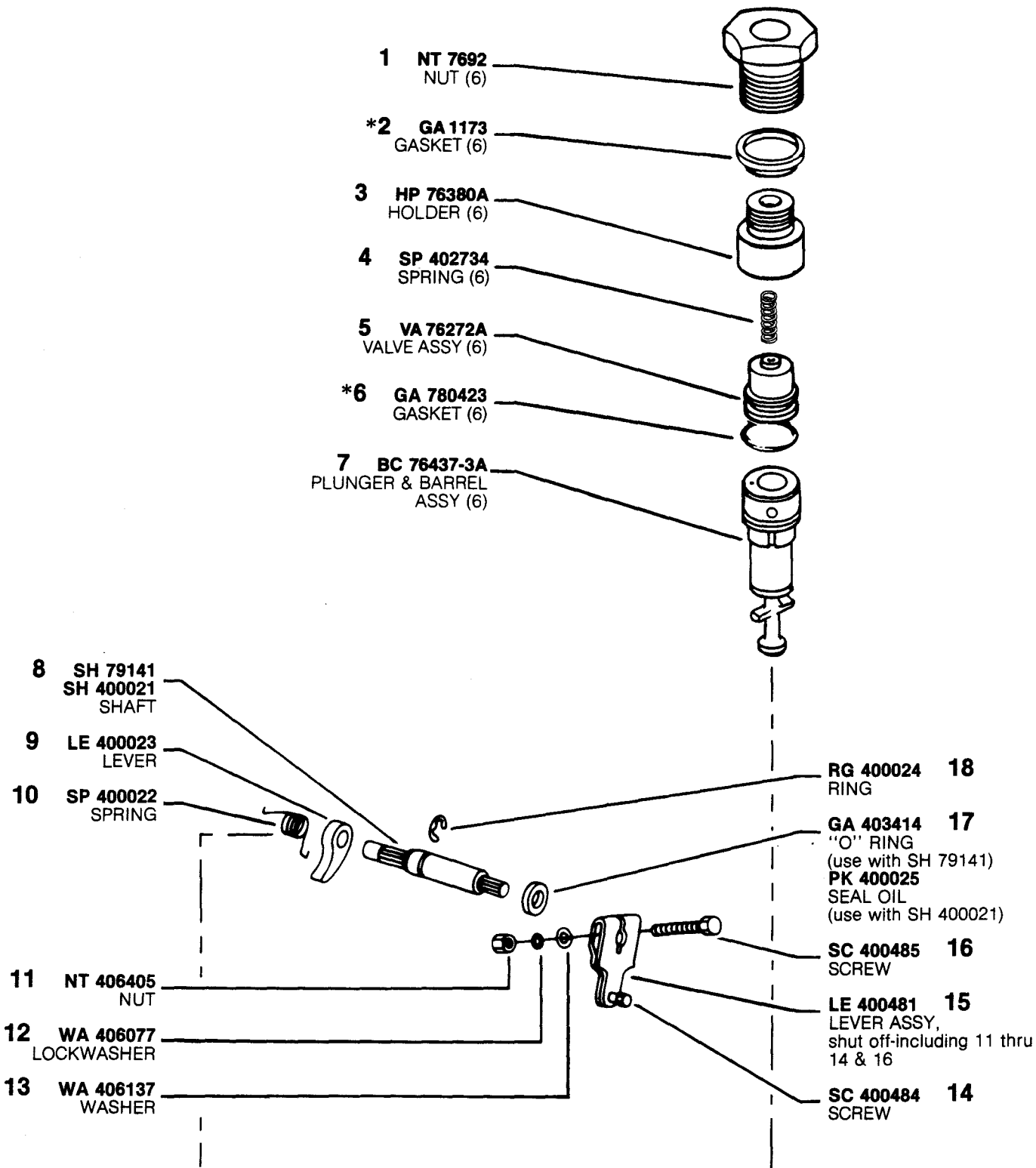

*Denotes parts included in "Pump & Governor Repair Gasket Kit" KT 76399-2.

MODEL APE 6BB 110T 7512A&B

ASSY SPA 22B2
 PUMP ASSY, supply-
 including 1 thru 9 & 11
 thru 16

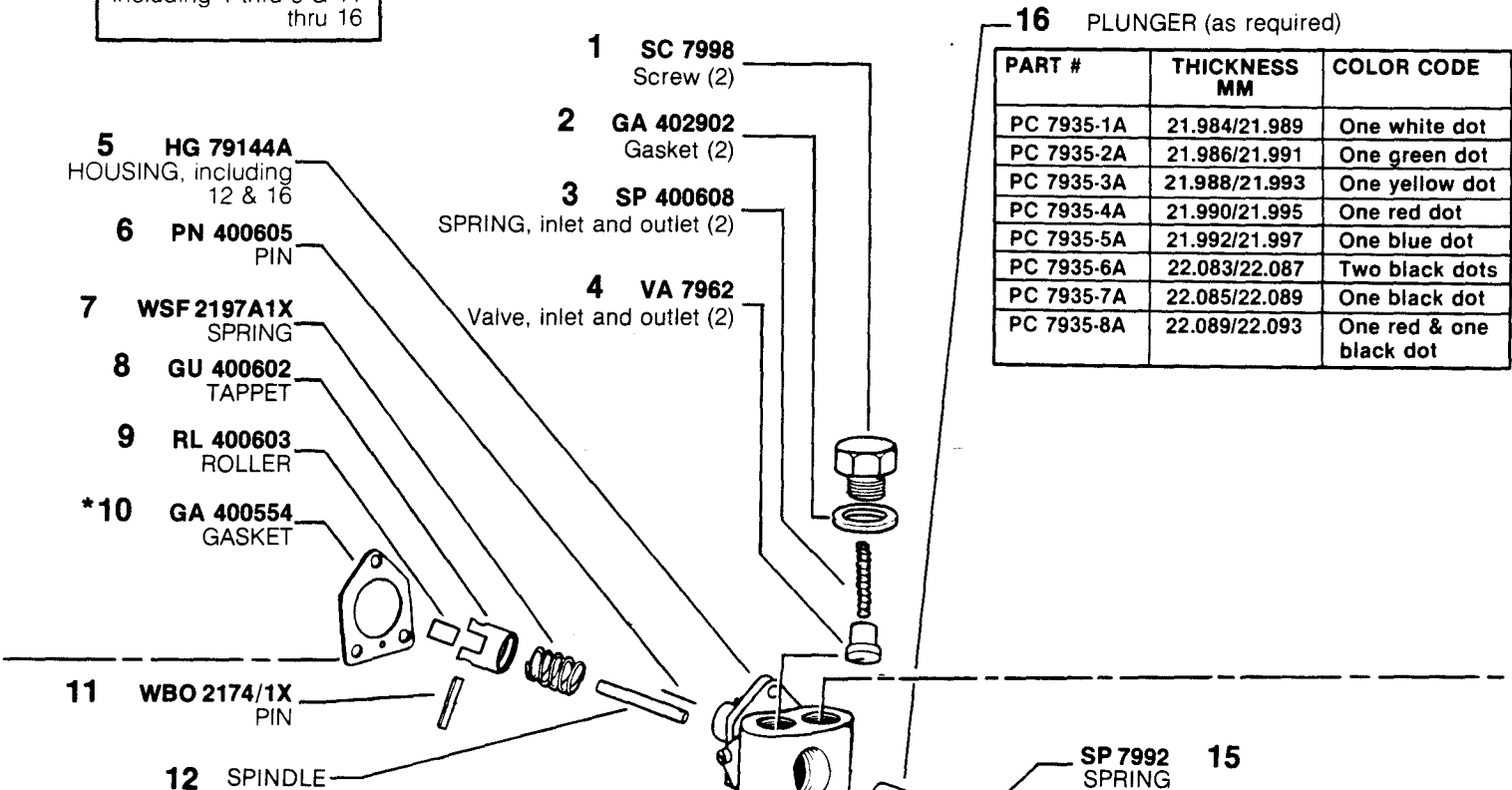

PART #	THICKNESS MM	COLOR CODE
PC 7935-1A	21.984/21.989	One white dot
PC 7935-2A	21.986/21.991	One green dot
PC 7935-3A	21.988/21.993	One yellow dot
PC 7935-4A	21.990/21.995	One red dot
PC 7935-5A	21.992/21.997	One blue dot
PC 7935-6A	22.083/22.087	Two black dots
PC 7935-7A	22.085/22.089	One black dot
PC 7935-8A	22.089/22.093	One red & one black dot

PART #	THICKNESS MM	COLOR CODE
SL 798-1	4.993/4.995	Red — one end
SL 798-2	4.995/4.997	Blue — one end
SL 798-3	4.997/4.999	Yellow — one end
SL 795-1	5.020/5.022	Yellow — one end White — one end
SL 795-2	5.044/5.046	Yellow — one end Black — one end
SL 795-3	5.067/5.069	White — one end Black — one end
SL 798-4	5.087/5.089	White — one end
SL 798-5	5.089/5.091	Black — one end
SL 798-6	5.091/5.093	Green — one end
SL 798-7	5.093/5.095	Aluminum — one end
SL 795-4	5.116/5.118	Aluminum — one end Red — one end
SL 795-5	5.039/5.141	Aluminum — one end Blue — one end
SL 795-6	5.162/5.164	Aluminum — one end Yellow — one end
SL 798-8	5.189/5.191	Red — both ends
SL 798-9	5.191/5.193	Blue — both ends
SL 798-10	5.193/5.195	Yellow — both end
SL 798-11	5.195/5.197	Black — both ends

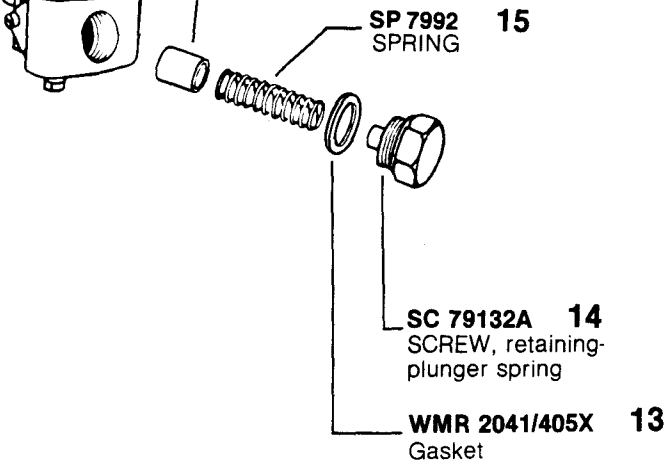

SPINDLE (requires reaming)

PART #	THICKNESS MM	COLOR CODE
SL 793-1	5.557/5.560	Red & Blue — one end
SL 793-2	5.561/5.564	Red & Green — one end
SL 793-3	5.565/5.568	Red & Yellow — one end
SL 793-4	5.569/5.572	Blue & Green — one end

MODEL APE 6BB 110T 7512A&B

ASSY MP 404760
MANUAL PRIMER
ASSY, including 3 thru 9
(Optional)

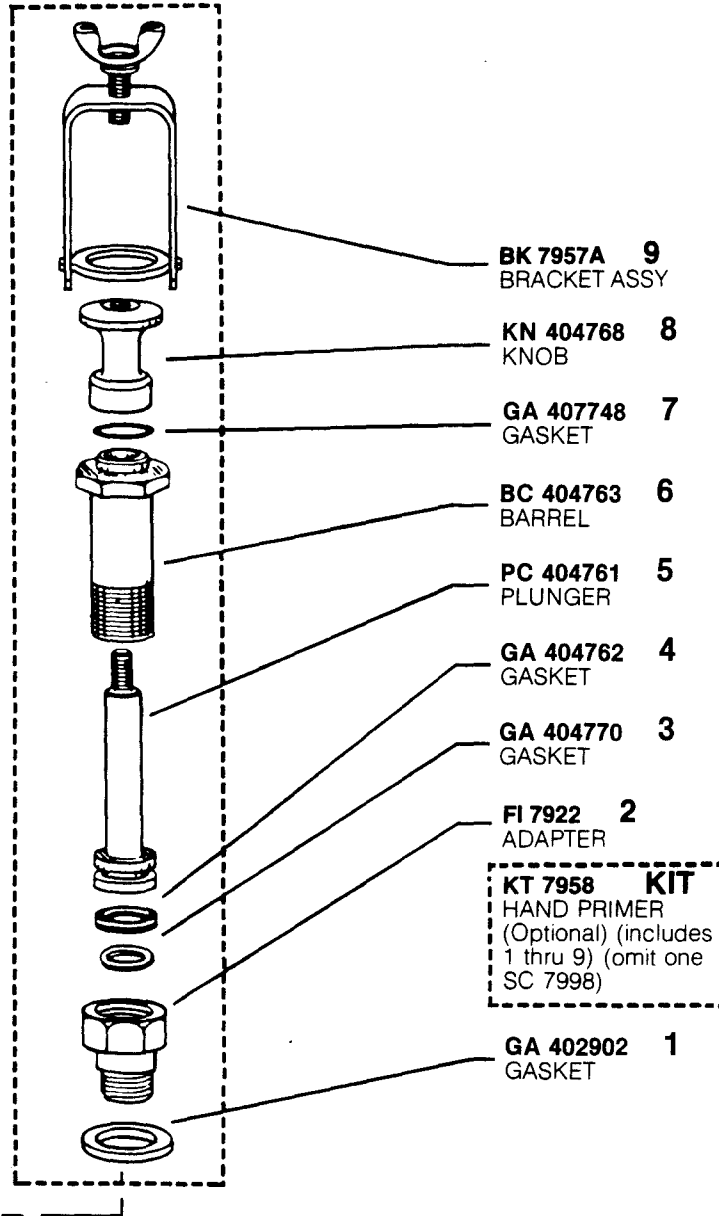

BK 7957A 9
BRACKET ASSY

KN 404768 8
KNOB

GA 407748 7
GASKET

BC 404763 6
BARREL

PC 404761 5
PLUNGER

GA 404762 4
GASKET

GA 404770 3
GASKET

FI 7922 2
ADAPTER

KT 7958 KIT
HAND PRIMER
(Optional) (includes
1 thru 9) (omit one
SC 7998)

GA 402902 1
GASKET

MODEL APE 6BB 110T 7512A&B

CALIBRATION SET-UP

Engine Holders HSN 780050
 Opening Pressure 4200-4350 psi
 Engine Nozzles NBM770000
 Engine Nozzle & Holder Assy Ref. #NHM780001
 High Pressure Tubing 1/4" OD x .067" ID
 x 39" Long

Calibrating Oil Viscor 1487C @ 100°-105°F
 (38-41°C) at pump inlet
 Lube Oil SAE #20 or #30 at 20 psi/1.4 bar
 Air Pressure 70-90 psi to air inlet cap
PROCEDURE Refer to the Service Instructions
 and use figure below

7512A&B CODE 1 DATA

Engine Model EM6-300R
 Engine Static Timing 24°
 Customer No. 313GC5152-P32
 Kit No. KT76524-1
 Customer Kit. No. 313GC5152-P31
 Governor Speeds 250/950
 Cam Nose Angle 94°(± 2°)

Governor Outer Spring
 Precompression Flush to 0.5mm (.020")
 Governor Inner Spring Gap .375-4.00mm(.148"-.157")
 Lift to Port Closing 3.00-3.20mm
 (.118"-.126"), cam lift with control rack at
 approximate mid-travel position

STEP	A	B	C Peak Torque (from actual A delivery)	D Droop Screw (from actual A delivery)
	Full Load at 1.180" Rack Ext	Cam Departure		
RPM	950	980	700	630
DEL cc/500 str	89.0-94.0	NONE	+ 17.0 ± 2.5	+ 23.5 ± 3.0
DEL cc/300 str	53.5-56.5	NONE	+ 10.5 ± 1.5	+ 14.0 ± 2.0

STEP	E	F	G	H
	"PLE"	Low Idle	Minimum Delivery	"Dual Speed" Cam Departure
RPM	800	300	75	860-870
DEL cc/500 str	59.0-63.0	12-14	—	NONE
DEL cc/300 str	35.5-38.0	7- 8.5	—	NONE
DEL cc/100 str	—	—	12.0	NONE

SERVICE CHECK — A, C & D are applicable.

Calibration data consist of latest calibration figures. Earlier editions may require changing parts to meet calibration requirements. See record of change chart.

RECORD OF CHANGE

EDITION	CAP	SPRING	SCREW, set
A	NONE	SP79120	SC8517
B	CP403392	SP401975	SC401836

NOTE: 7512A used HG79301A. "A" edition should be updated to "B" edition to meet calibration requirement. HG 79301A can be updated by changing spring (22 on p. 2), and adding cap (25 on p.2) called for in parts list.

IMPORTANT: SC401836 (15 on p.3) must be used when updating to "B" edition.

NOTE ON ELIMINATION OF CENTER BEARING IN APE 6BB FUEL INJECTION PUMPS

INFORMATION:

Latest APE 6BB fuel injection pumps do not incorporate center bearings and accordingly, pump housings and cam shafts are no longer machined to provide for use of the part.

For earlier type APE 6BB pumps, elimination of the center bearing is **OPTIONAL**.

CAUTION: Prior to assembly of a camshaft and center bearing to a pump, first determine that the bearing can physically be used. Insure that there are holes in the housing for the bearing retaining screws and that the journal between cam lobes #3 and #4 has been machined to accept the part.

If a housing has been machined to accept a center bearing and the bearing is not to be utilized, then the screw holes must be plugged per the following instructions:

INSTRUCTIONS:

Plug center bearing screw holes as follows:

1. Clean out screw hole counterbores.
2. Press plug, PG 400760 into each hole.
3. Seal plug in hole with Devcon F, or an equivalent epoxy.

NOTE: Elimination of the center bearing is only to be undertaken if the initial service problem required removal of the camshaft from the pump.

THIS NOTE SUPERCEEDS MODEL 6BBT, SERVICE BULLETIN S7.

MODEL APE 6BB 110T 7512A&B