

**7540**

**A**

**PUMP ROTATION:**  
Clockwise: Firing Order: 1-5-3-6-2-4  
**DRIVE END:**  
R. H. Side  
**TIMED FOR PORT CLOSING**  
**SPECIAL FEATURES:**

MACK  
**APE 6BB 110T 7540A**

**Special Information:**



### SERVICE PARTS

Following are all parts, part numbers, pump codes and calibrations for the *Model: APE 6BB 110T 7540A*. The exploded view drawing below is detailed with part numbers

listed on the pages indicated. Refer to the Index Section for explanations of codes and abbreviations.

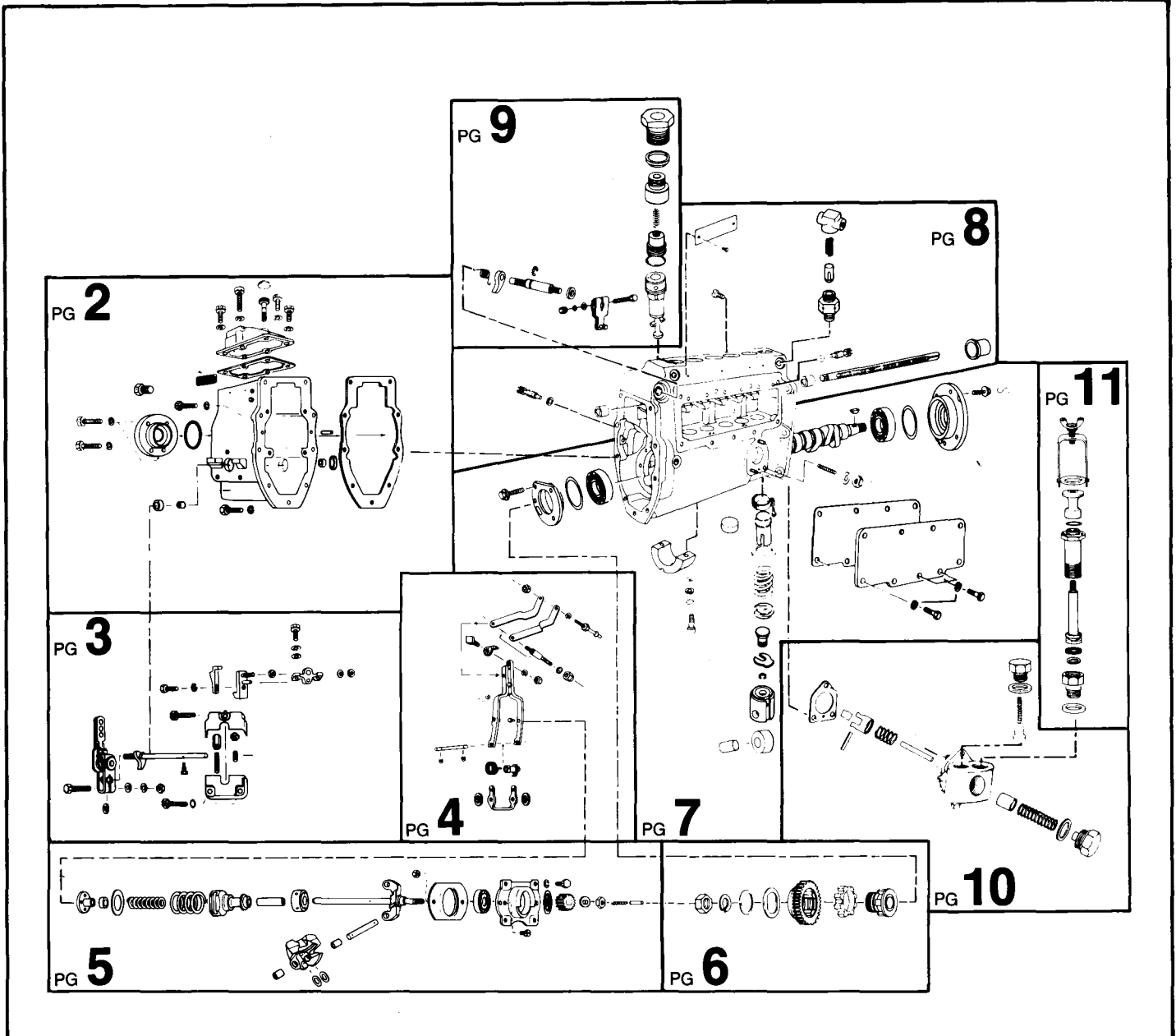

# MODEL APE 6BB 110T 7540A

**ASSY GVB/E 7541**  
GOVERNOR ASSY

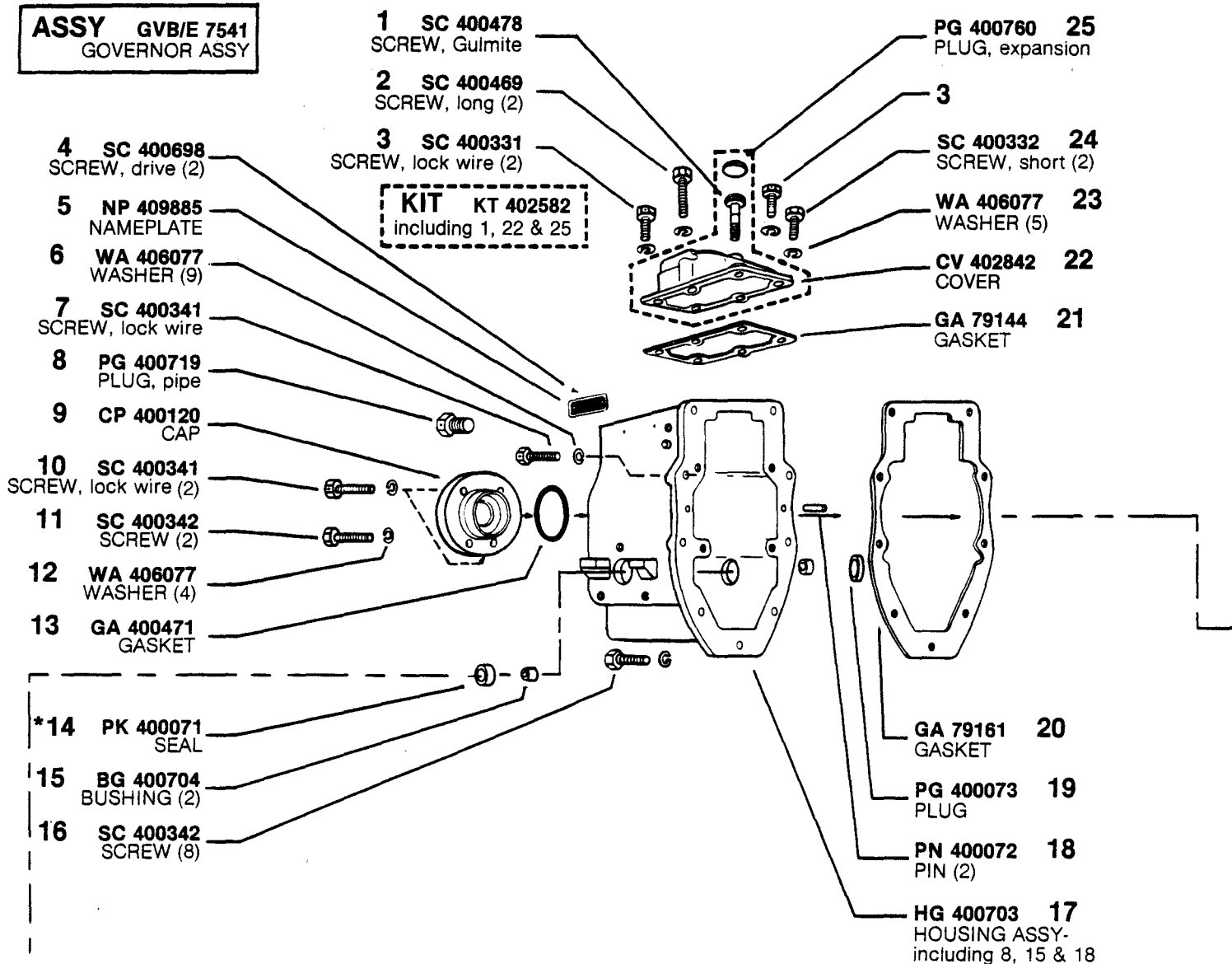

\*Quantity used is one, unless otherwise indicated in parenthesis ( ) following description of part.

\*Denotes parts included in "Pump & Governor Repair Gasket Kit", KT 76399-2.

# MODEL APE 6BB 110T 7540A

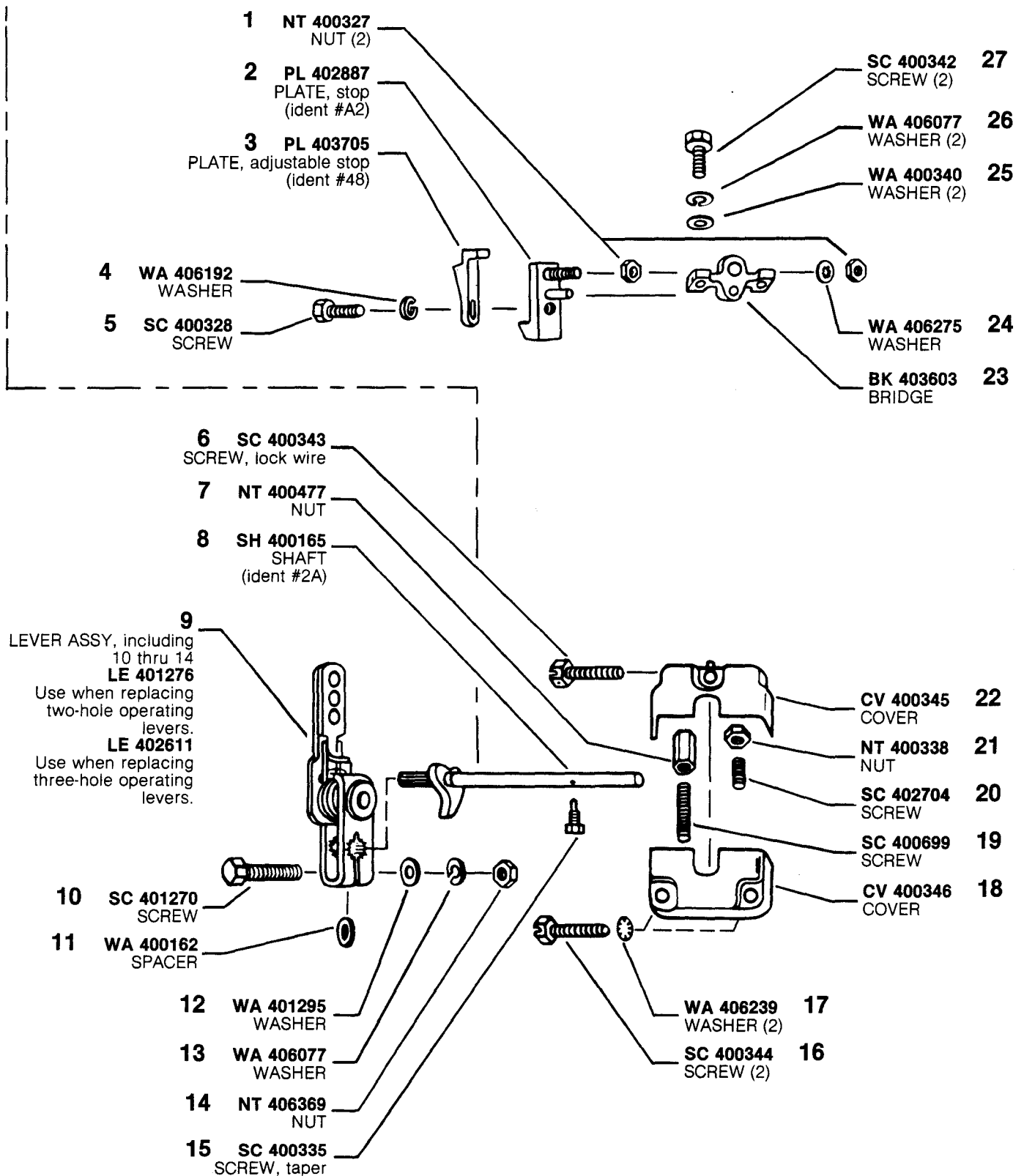

## MODEL APE 6BB 110T 7540A

**ASSY LE 400782**  
 LEVER ASSY, fulcrum-  
 including 1, 2, 6 thru 8,  
 10, 12 & 15 thru 20

**ASSY PL 400177**  
 PLATE ASSY, including  
 9 & 11

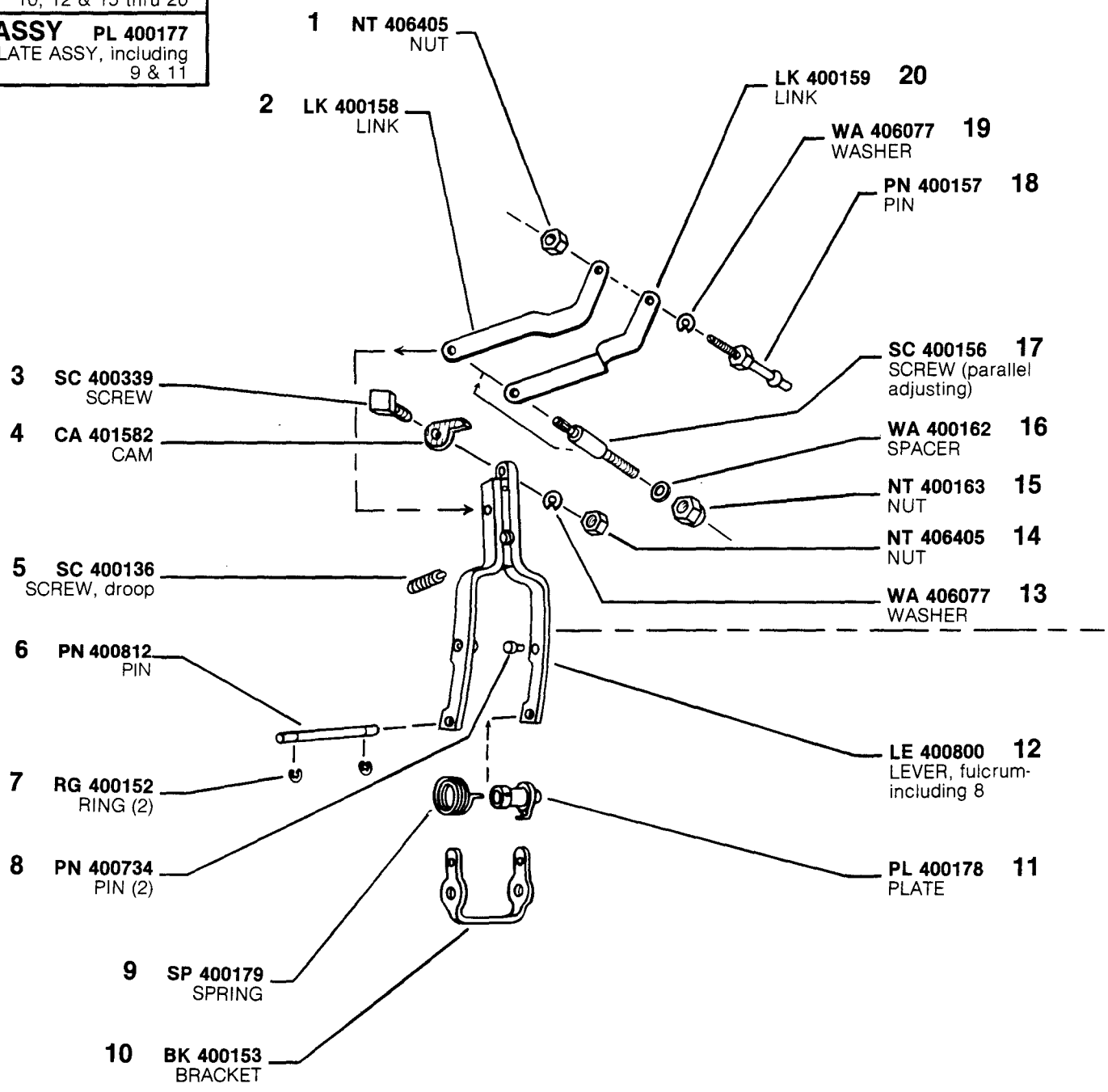

# MODEL APE 6BB 110T 7540A

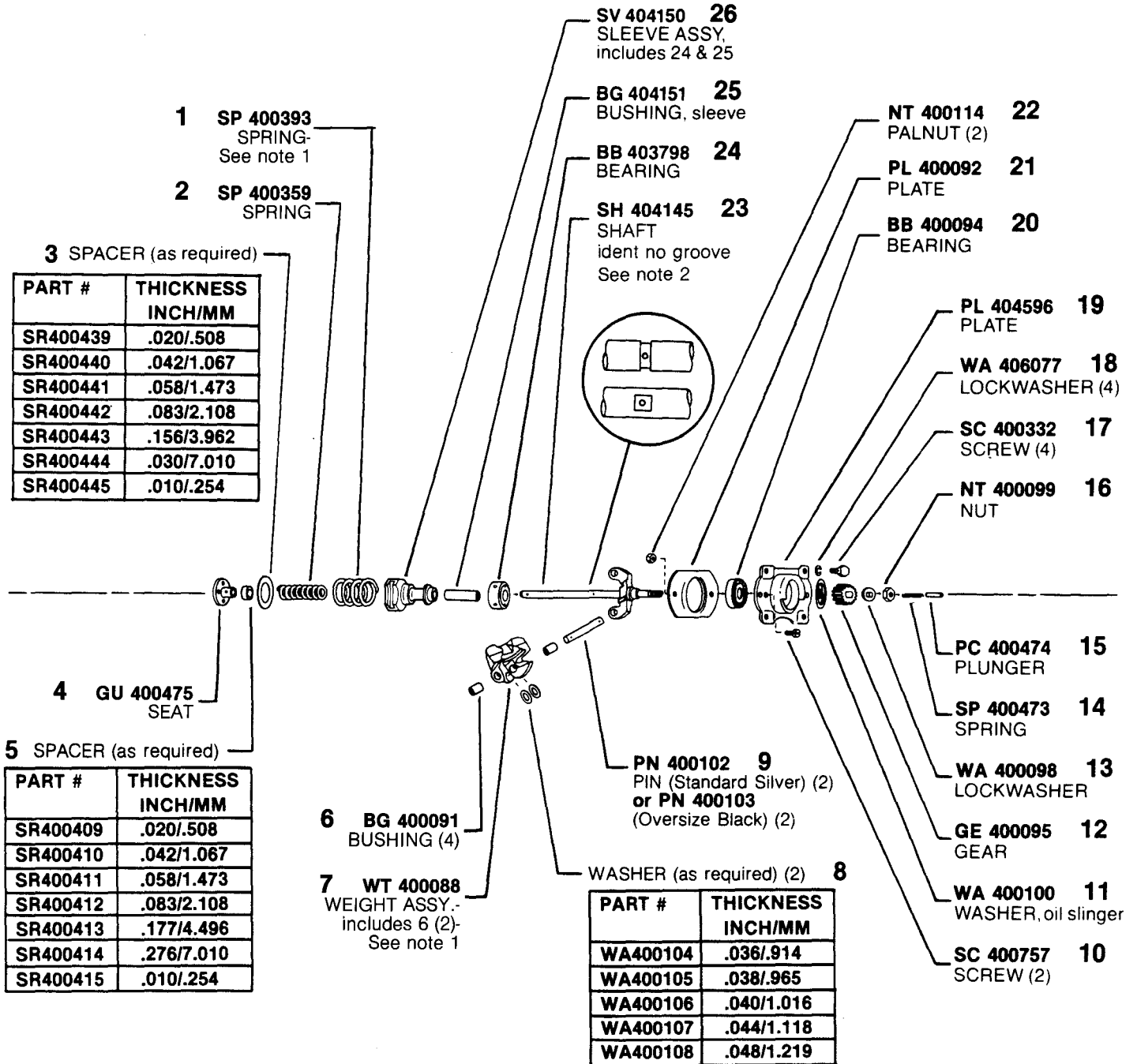

NOTE: 1. Per Service Bulletin S15, use WT 403453 (no low idle pin) when engine experiences idle surge/poor governor response at 1000 ERPM range. Governor outer spring (#1) SP 400404 must also be used and "P" must be stamped on governor nameplate to identify the changeover.

2. When replacing shaft (#23 w/groove) with latest shaft (SH404145 no groove) BG404151 (25) MUST be used. Shaft with groove used BG400118.

# MODEL APE 6BB 110T 7540A

**ASSY GE 408663**  
**(RUBBER DRIVE)**  
 DRIVE ASSY, includes  
 3 thru 7

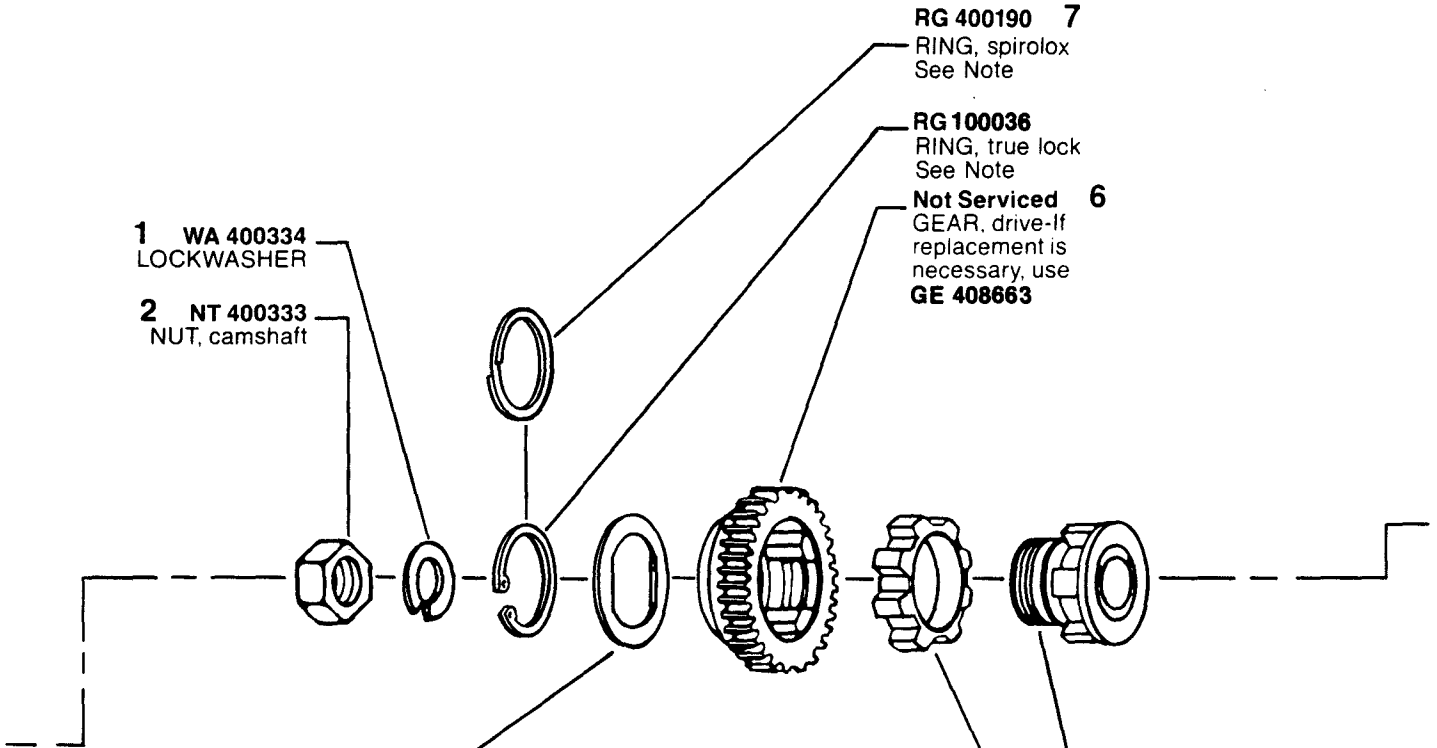

**1** WA 400334  
LOCKWASHER

**2** NT 400333  
NUT, camshaft

**RG 400190 7**  
RING, spirolox  
See Note

**RG 100036**  
RING, true lock  
See Note

**Not Serviced 6**  
GEAR, drive-If  
replacement is  
necessary, use  
**GE 408663**

**3** SPACER (as required)

**Not Serviced 5**  
HUB, drive-If  
replacement is  
necessary, use  
**GE 408663**

**IT 400189 4**  
INSERT, drive

PART #	THICKNESS INCH/MM
SR400191	.065/1.65
SR400192	.070/1.78
SR400193	.075/1.90
SR400194	.080/2.03
SR400195	.085/2.16
SR400196	.0625/1.59
SR400197	.060/1.52
SR400198	.0675/1.71
SR400199	.0725/1.84
SR400200	.0775/1.97
SR400201	.0825/2.10
SR400202	.0875/2.22

#7 NOTE: Earlier rubber drive assy GE 400182 used RG 400190 (Spirolox ring), later assy GE 408663 using RG 100036 (true lock ring). Spirolox & true lock rings are NOT interchangeable.

**ASSY** NOTE: Pumps equipped with GE 7992A "Friction Clutch" refer to Service Instructions Model 6BBT Parts Bulletin P4 for Parts.

# MODEL APE 6BB 110T 7540A

**ASSY TP 7651A**  
TAPPET ASSY-  
including 12-17 (6)

**ASSY HG 761246-1A**  
HOUSING ASSY-  
including 31; 4 on page  
8; and 8 thru 10, 17 &  
18 on page 9  
See note

**3** SPACER (as required)

PART #	THICKNESS INCH/MM
SR 7611-1	.008/0.2
SR 7611-2	.012/0.3
SR 7611-3	.016/0.4
SR 7611-4	.004/0.1
SR 7611-5	.006/0.15
SR 7611-6	.002/0.05
SR 7611-7	.032/0.8

**1** KY 403378  
KEY, WOODRUFF  
(Earlier Camshafts  
require KY 764)

**2** SH 76121  
CAMSHAFT  
See note

**RB 1004 35**  
BEARING (2)

**PL 76113 34**  
PLATE

**SC 400331 33**  
SCREW (3)

**WI 763 32**  
WIRE

**SD 40005 31**  
STUD (3)

**WA 406077 30**  
LOCKWASHER (3)

**NT 400555 29**  
NUT (3)

**GA 76309 \*28**  
GASKET

**CV 76312 27**  
COVER

**WA 406078 26**  
WASHER (9)

**SC 1865 25**  
SCREW,  
wire seal (2)

**SC 1863 24**  
SCREW (7)

**GE 400643 23**  
GEAR (6)

**SC 400486 22**  
SCREW, gear (6)

**SV 7671 21**  
SLEEVE (6)

**GU 400510 20**  
SEAT (6)

**SP 76149 19**  
SPRING (6)

**GU 402592 18**  
SEAT (6)

**RG 7618 17**  
RING, snap (6)

**GU 76159 16**  
SHELL (6)

**RL 7613A 15**  
ROLLER (6)

**PN 7648 14**  
PIN (6)

**4** SC 403602  
SCREW (4)

**5** PL 76117  
PLATE

**6** (see note)  
BEARING, center

**\*7** GA 5264  
GASKET (2)

**8** WA 1518  
WASHER (2)

**9** WA 406006  
LOCKWASHER (2)

**10** SC 400064  
SCREW (2)

**11** PG 7669  
PLUG (6)

**12** KN 7610  
KNOB (6)

**13** SPACER  
(as required)

PART #	THICKNESS INCH/MM
SR 7610-1	.050/1.270
SR 7610-2	.054/1.372
SR 7610-3	.058/1.473
SR 7610-4	.062/1.575
SR 7610-5	.066/1.676
SR 7610-6	.046/1.168
SR 7610-7	.048/1.219
SR 7610-8	.052/1.321

PART #	THICKNESS INCH/MM
SR 7610-9	.056/1.422
SR 7610-10	.060/1.524
SR 7610-11	.064/1.626
SR 7610-15	.042/1.067
SR 7610-16	.044/1.118
SR 7610-17	.068/1.727
SR 7610-18	.072/1.829

NOTE: Latest pump housings and camshafts do not allow use of center bearing. If bearing is not to be used, refer to note on page 13 (PG 400760 information)

# MODEL APE 6BB 110T 7540A

\*Denotes parts included in "Pump & Governor Repair Gasket Kit" KT 76399-2.

**ASSY VA 400683**  
 VALVE ASSY, overflow-  
 including 11 thru 14-  
 Assemble overflow  
 valve at drive end side  
 of pump.

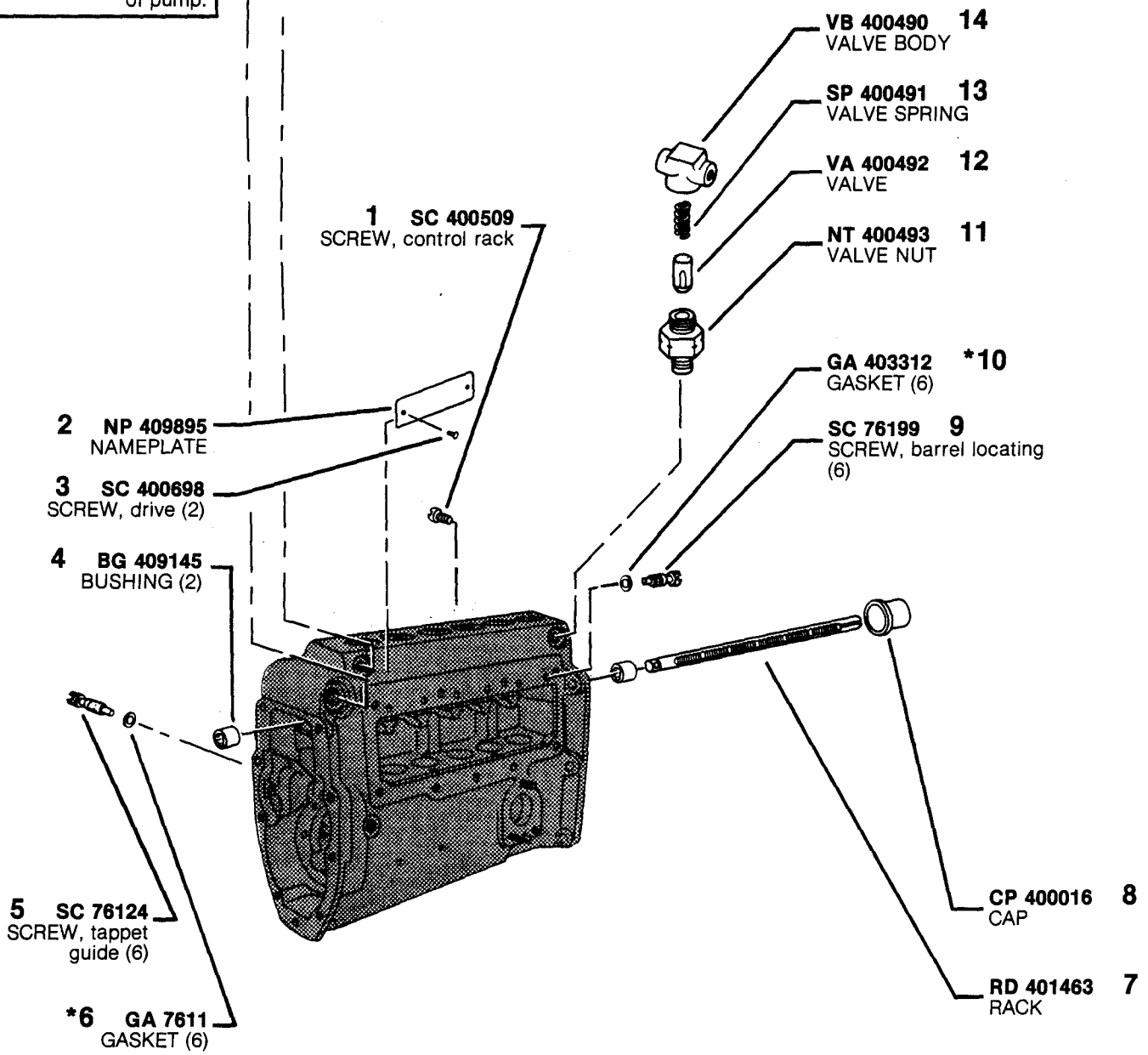

\*Denotes parts included in "Pump & Governor Repair Gasket Kit" KT 76399-2.

## MODEL APE 6BB 110T 7540A

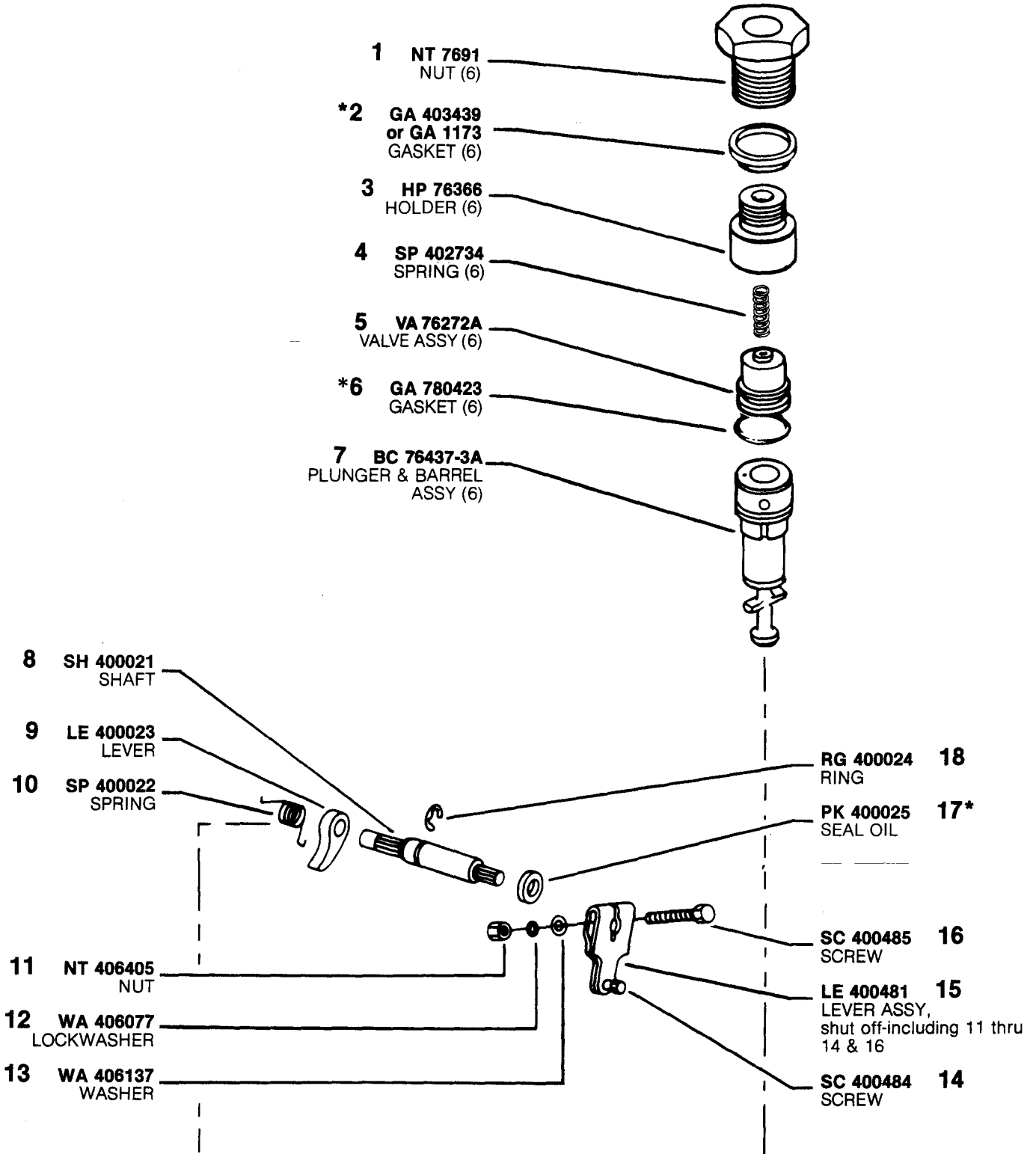

\*Denotes parts included in "Pump & Governor Repair Gasket Kit" KT 76399-2.

# MODEL APE 6BB 110T 7540A

**ASSY SPA 22B2**  
 PUMP ASSY, supply-  
 including 1 thru 9 & 11  
 thru 16

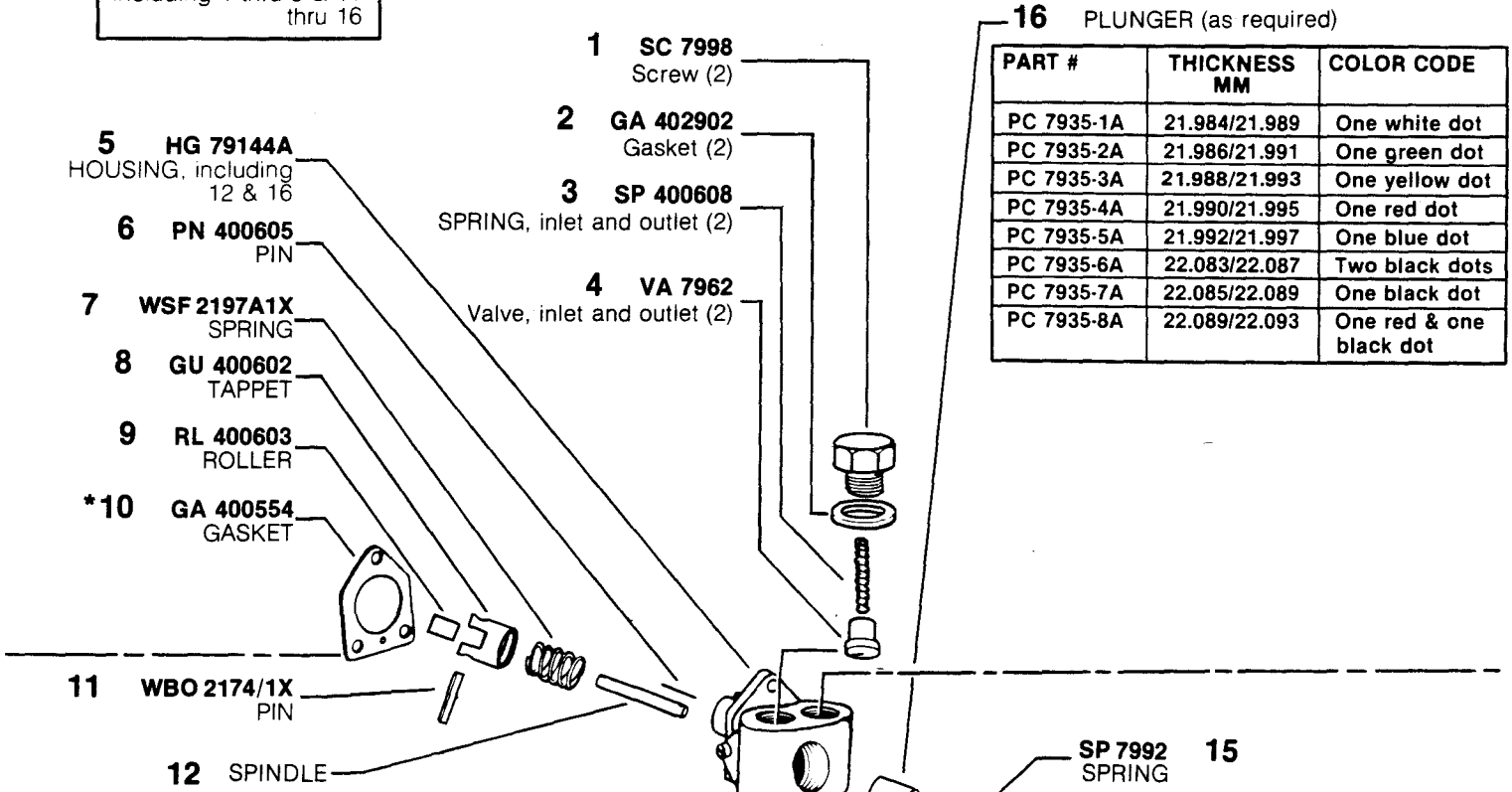

**16 PLUNGER (as required)**

PART #	THICKNESS MM	COLOR CODE
PC 7935-1A	21.984/21.989	One white dot
PC 7935-2A	21.986/21.991	One green dot
PC 7935-3A	21.988/21.993	One yellow dot
PC 7935-4A	21.990/21.995	One red dot
PC 7935-5A	21.992/21.997	One blue dot
PC 7935-6A	22.083/22.087	Two black dots
PC 7935-7A	22.085/22.089	One black dot
PC 7935-8A	22.089/22.093	One red & one black dot

PART #	THICKNESS MM	COLOR CODE
SL 798-1	4.993/4.995	Red — one end
SL 798-2	4.995/4.997	Blue — one end
SL 798-3	4.997/4.999	Yellow — one end
SL 795-1	5.020/5.022	Yellow — one end White — one end
SL 795-2	5.044/5.046	Yellow — one end Black — one end
SL 795-3	5.067/5.069	White — one end Black — one end
SL 798-4	5.087/5.089	White — one end
SL 798-5	5.089/5.091	Black — one end
SL 798-6	5.091/5.093	Green — one end
SL 798-7	5.093/5.095	Aluminum — one end
SL 795-4	5.116/5.118	Aluminum — one end Red — one end
SL 795-5	5.039/5.141	Aluminum — one end Blue — one end
SL 795-6	5.162/5.164	Aluminum — one end Yellow — one end
SL 798-8	5.189/5.191	Red — both ends
SL 798-9	5.191/5.193	Blue — both ends
SL 798-10	5.193/5.195	Yellow — both end
SL 798-11	5.195/5.197	Black — both ends

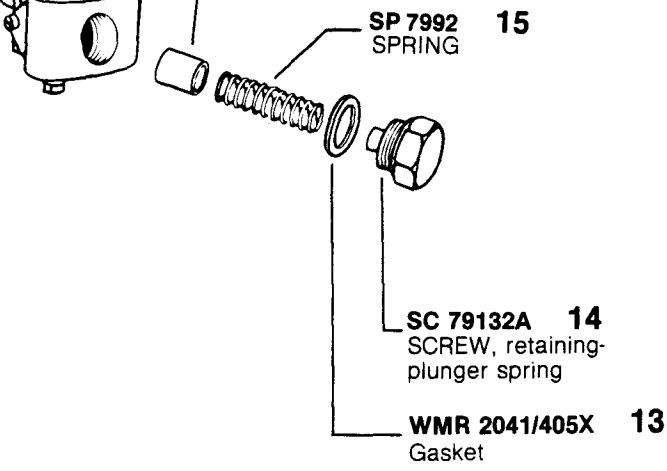

SPINDLE (requires reaming)

PART #	THICKNESS MM	COLOR CODE
SL 793-1	5.557/5.560	Red & Blue — one end
SL 793-2	5.561/5.564	Red & Green — one end
SL 793-3	5.565/5.568	Red & Yellow — one end
SL 793-4	5.569/5.572	Blue & Green — one end

# MODEL APE 6BB 110T 7540A

**ASSY MP 404760**  
MANUAL PRIMER  
ASSY, including 3 thru 9  
(Optional)

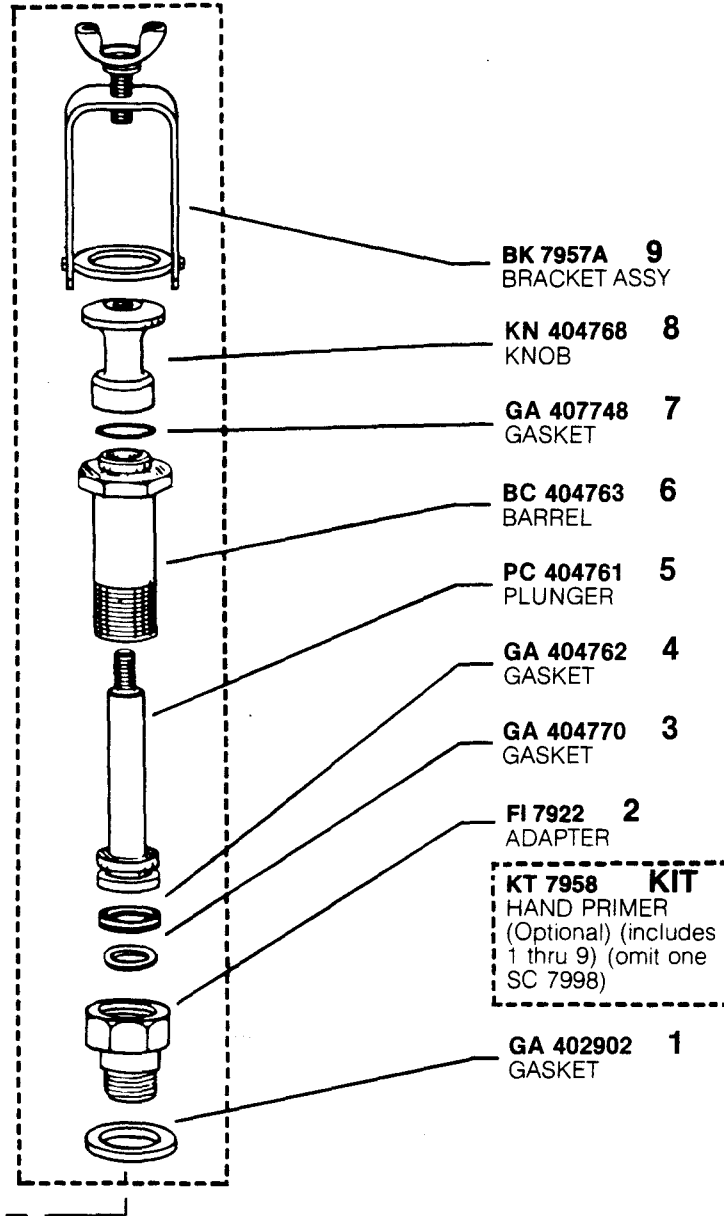

**MODEL APE 6BB 110T 7540A**



**NOTE ON ELIMINATION OF CENTER BEARING  
IN APE 6BB FUEL INJECTION PUMPS****INFORMATION:**

Latest APE 6BB fuel injection pumps do not incorporate center bearings and accordingly, pump housings and cam shafts are no longer machined to provide for use of the part.

For earlier type APE 6BB pumps, elimination of the center bearing is OPTIONAL.

**CAUTION:** Prior to assembly of a camshaft and center bearing to a pump, first determine that the bearing can physically be used. Insure that there are holes in the housing for the bearing retaining screws and that the journal between cam lobes #3 and #4 has been machined to accept the part.

If a housing has been machined to accept a center bearing and the bearing is not to be utilized, then the screw holes must be plugged per the following instructions:

**INSTRUCTIONS:**

Plug center bearing screw holes as follows:

1. Clean out screw hole counterbores.
2. Press plug, PG 400760 into each hole.
3. Seal plug in hole with Devcon F, or an equivalent epoxy.

**NOTE:** Elimination of the center bearing is only to be undertaken if the initial service problem required removal of the camshaft from the pump.

**THIS NOTE SUPERCEEDS MODEL 6BBT, SERVICE BULLETIN S7.**

---

**MODEL APE 6BB 110T 7540A**