

7548

A

PUMP ROTATION:
Clockwise: Firing Order: 1-5-3-6-2-4
DRIVE END:
R. H. Side
TIMED FOR PORT CLOSING
SPECIAL FEATURES:
"Dual Speed"

MACK
APE 6BB 110T 7548A

Special Information:



SERVICE PARTS

Following are all parts, part numbers, pump codes and calibrations for the Model: APE 6BB 110T 7548A. The exploded view drawing below is detailed with part numbers

listed on the pages indicated. Refer to the Index Section for explanations of codes and abbreviations.

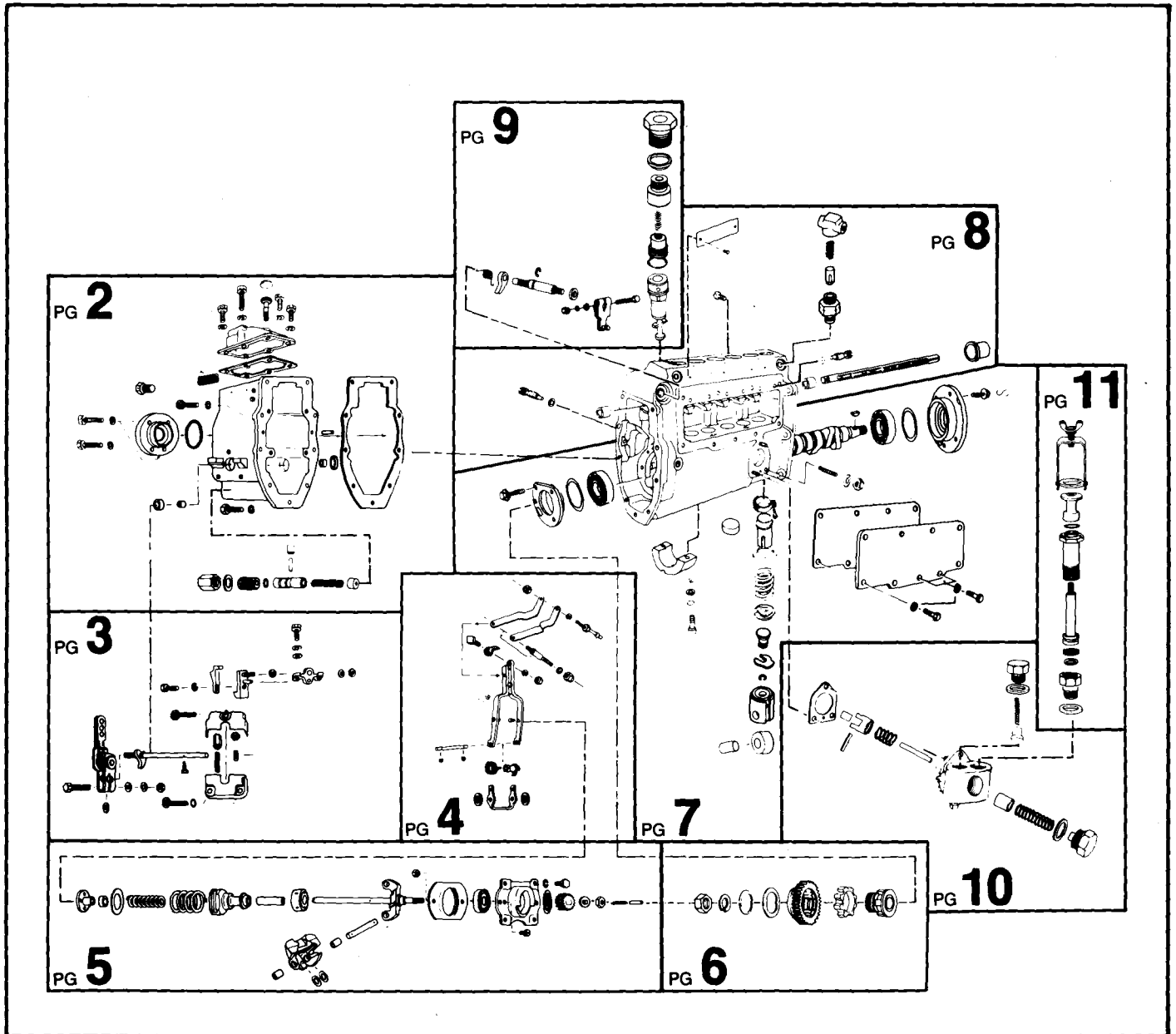

MODEL APE 6BB 110T 7548A

ASSY GVB/E 7549
GOVERNOR ASSY

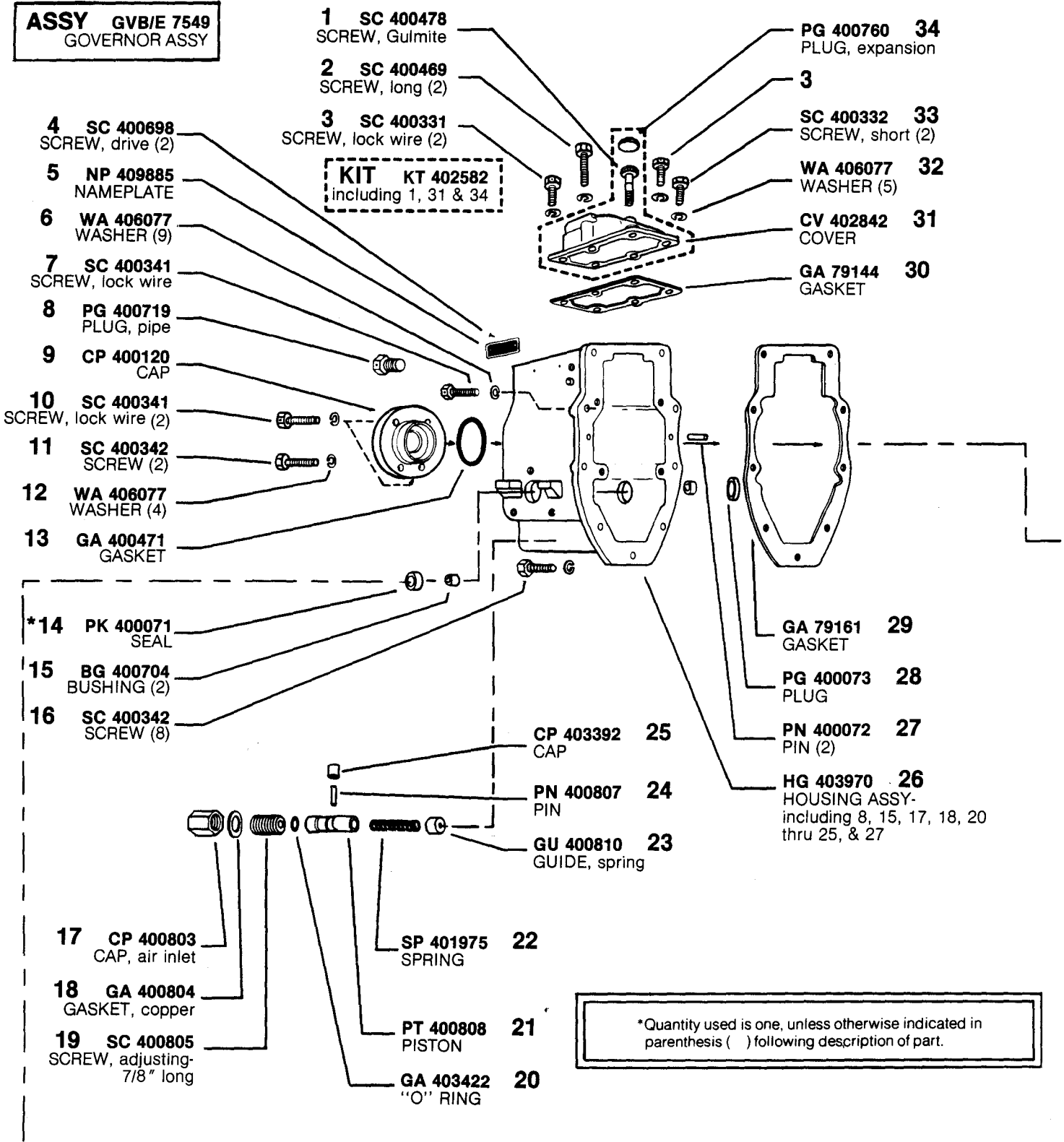

*Quantity used is one, unless otherwise indicated in parenthesis () following description of part.

*Denotes parts included in "Pump & Governor Repair Gasket Kit", KT 76399-2.

MODEL APE 6BB 110T 7548A

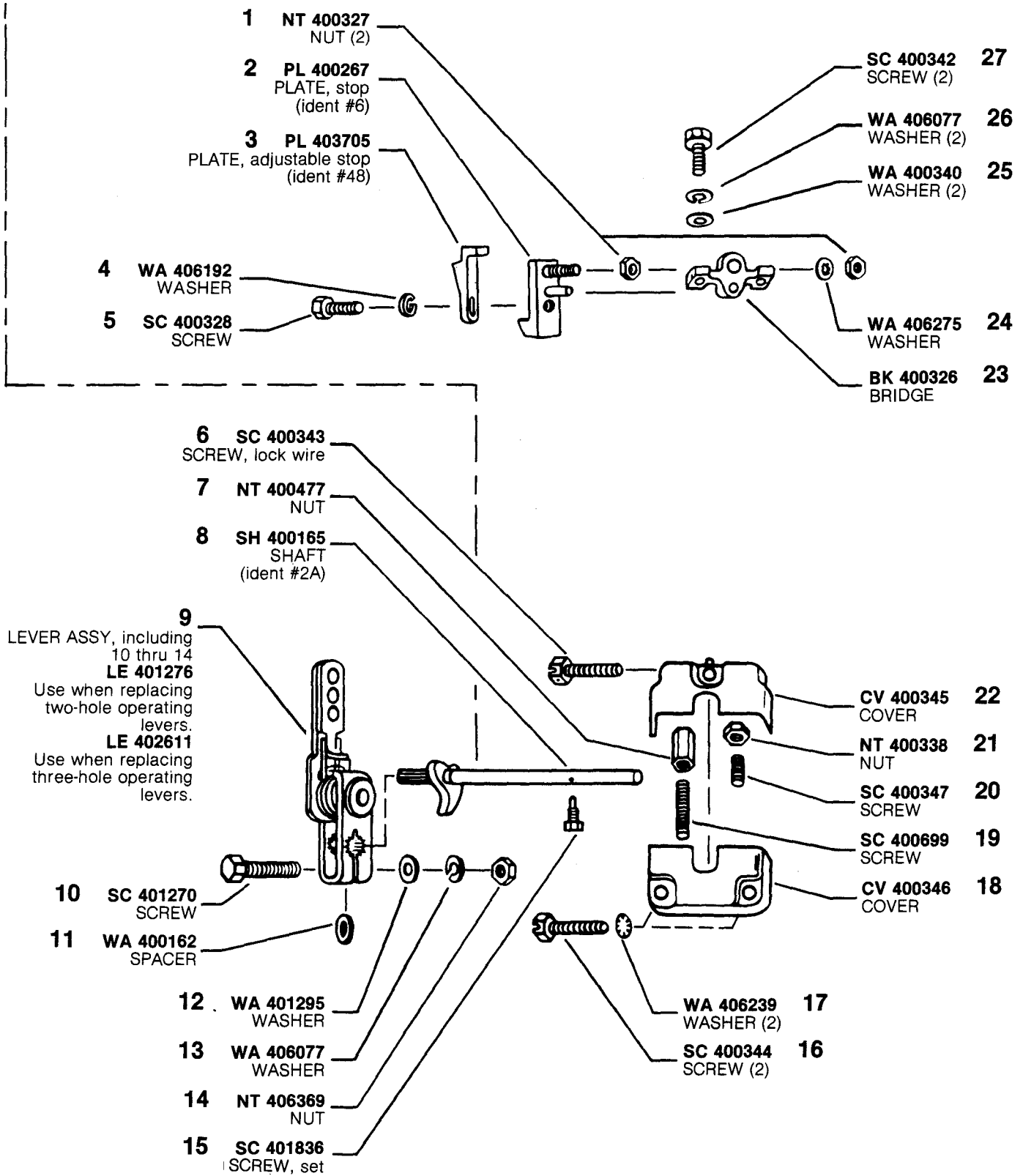

MODEL APE 6BB 110T 7548A

ASSY LE 400782
 LEVER ASSY, fulcrum-
 including 1, 2, 6 thru 8,
 10, 12 & 15 thru 20

ASSY PL 400177
 PLATE ASSY, including
 9 & 11

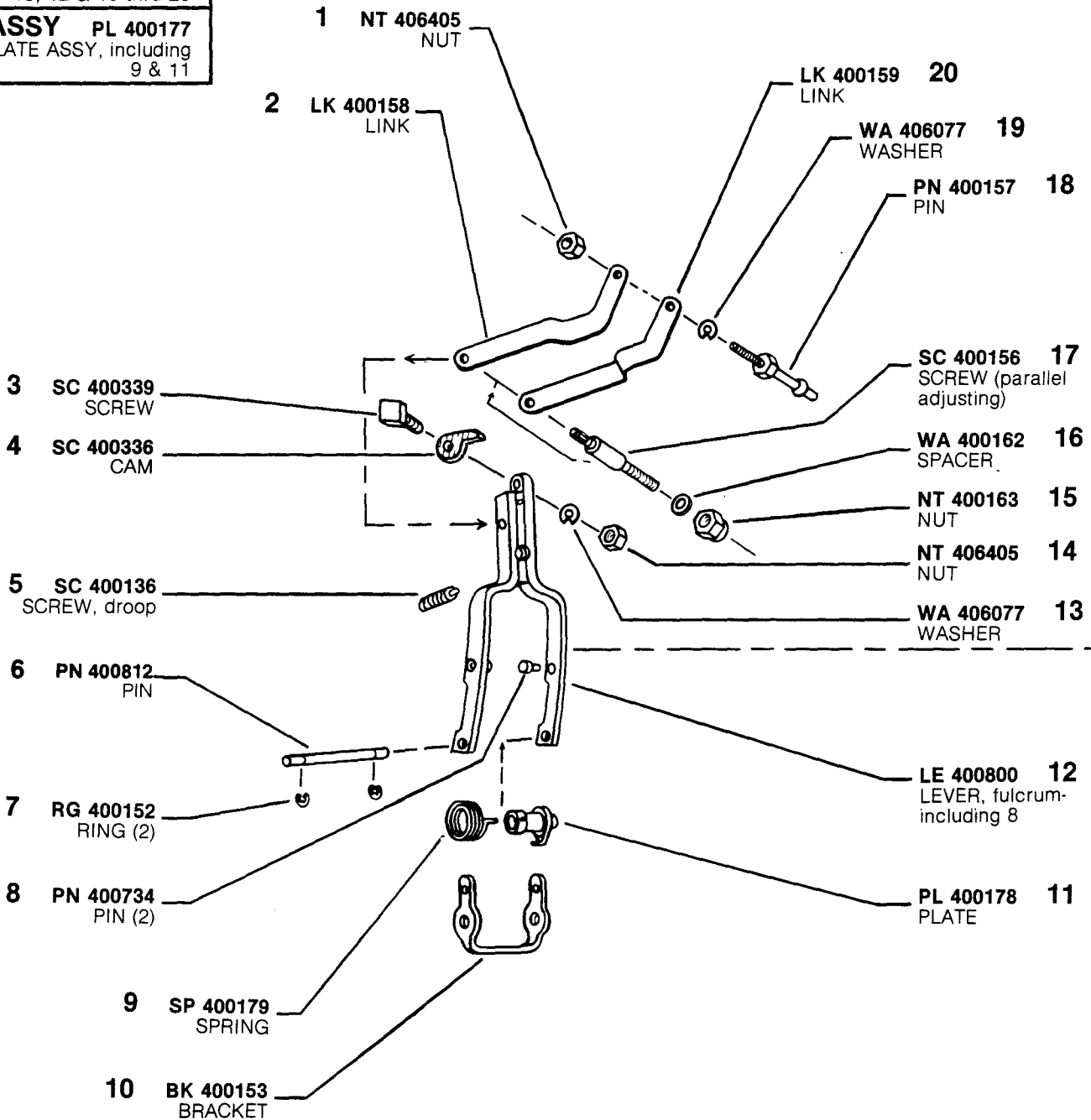

MODEL APE 6BB 110T 7548A

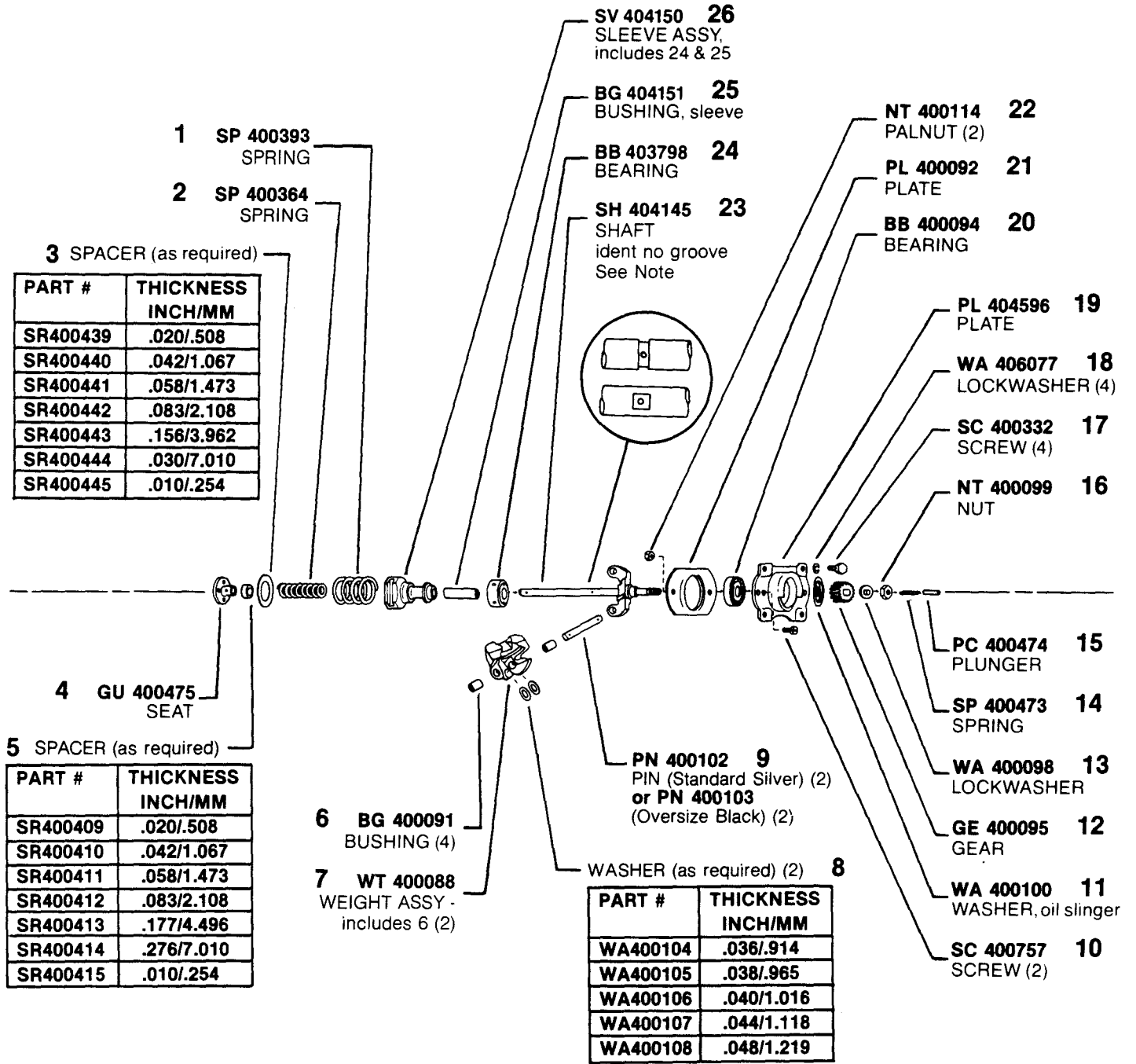

NOTE: When replacing shaft (#23 w/groove) with latest shaft (SH404145 no groove) BG404151 (25) MUST be used. Shaft with groove used BG400118.

MODEL APE 6BB 110T 7548A

ASSY GE 408663
(RUBBER DRIVE)
 DRIVE ASSY, includes
 3 thru 7

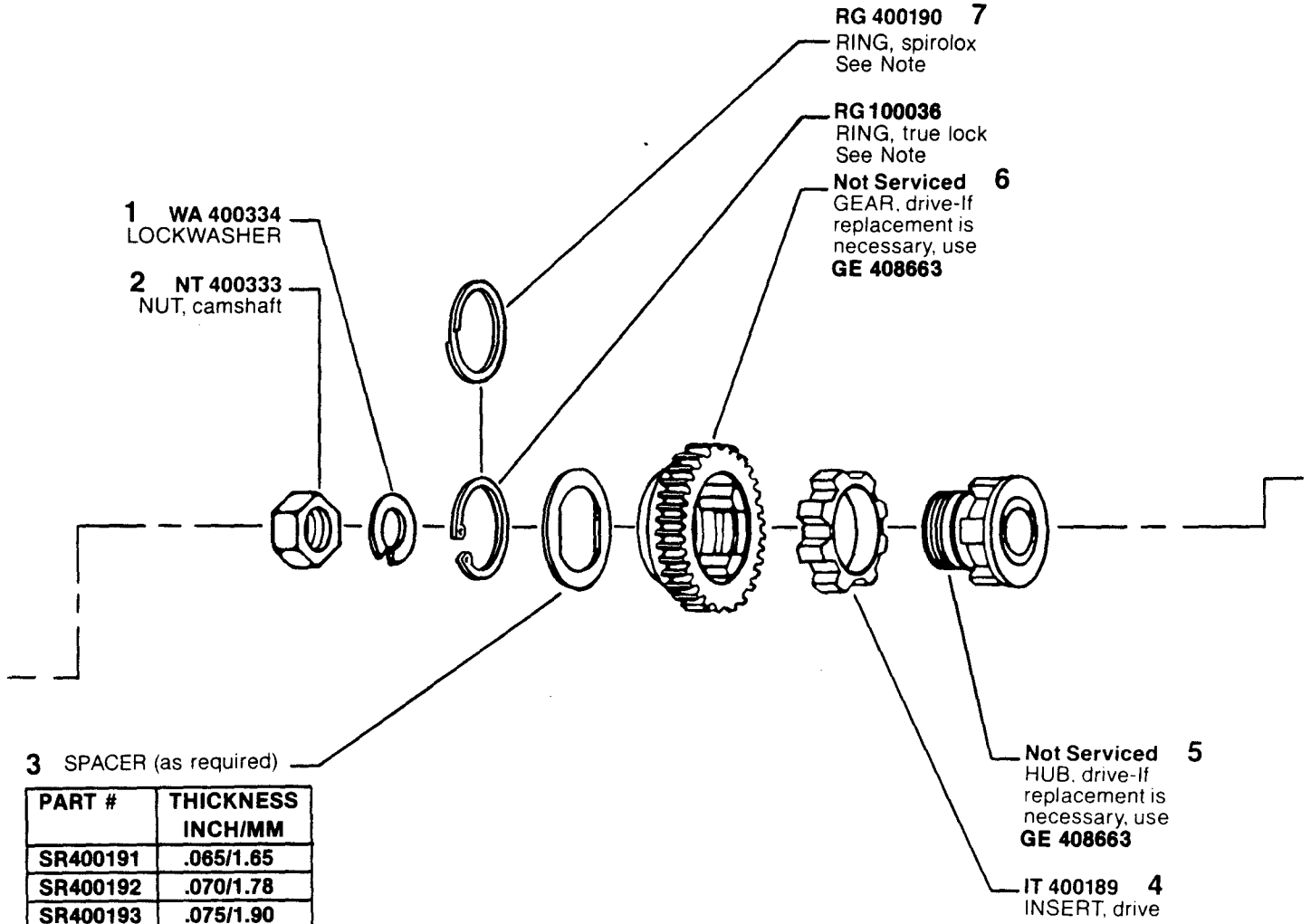

PART #	THICKNESS INCH/MM
SR400191	.065/1.65
SR400192	.070/1.78
SR400193	.075/1.90
SR400194	.080/2.03
SR400195	.085/2.16
SR400196	.0625/1.59
SR400197	.060/1.52
SR400198	.0675/1.71
SR400199	.0725/1.84
SR400200	.0775/1.97
SR400201	.0825/2.10
SR400202	.0875/2.22

#7 NOTE: Earlier rubber drive assy GE 400182 used RG 400190 (Spirolox ring), later assy GE 408663 using RG 100036 (true lock ring). Spirolox & true lock rings are NOT interchangeable.
 ASSY NOTE: Pumps equipped with GE 7992A "Friction Clutch" refer to Service Instructions Model 6BBT Parts Bulletin P4 for Parts.

MODEL APE 6BB 110T 7548A

ASSY TP 7651A
TAPPET ASSY-
including 12-17 (6)

ASSY HG 761246-1A
HOUSING ASSY-
including 31; 4 on page
8; and 8 thru 10, 17 &
18 on page 9
See note

3 SPACER (as required)

PART #	THICKNESS INCH/MM
SR 7611-1	.008/0.2
SR 7611-2	.012/0.3
SR 7611-3	.016/0.4
SR 7611-4	.004/0.1
SR 7611-5	.006/0.15
SR 7611-6	.002/0.05
SR 7611-7	.032/0.8

1 KY 403378
KEY, WOODRUFF
(Earlier Camshafts
require KY 764)

2 SH 76121
CAMSHAFT
See note

RB 1004 35
BEARING (2)

PL 76113 34
PLATE

SC 400331 33
SCREW (3)

WI 763 32
WIRE

SD 400005 31
STUD (3)

WA 406077 30
LOCKWASHER (3)

NT 400555 29
NUT (3)

GA 76309 *28
GASKET

CV 76312 27
COVER

WA 406078 26
WASHER (9)

SC 1865 25
SCREW,
wire seal (2)

SC 1863 24
SCREW (7)

GE 400643 23
GEAR (6)

SC 400486 22
SCREW, gear (6)

SV 7671 21
SLEEVE (6)

GU 400510 20
SEAT (6)

SP 76149 19
SPRING (6)

GU 402592 18
SEAT (6)

RG 7618 17
RING, snap (6)

GU 76159 16
SHELL (6)

RL 7613A 15
ROLLER (6)

PN 7648 14
PIN (6)

4 SC 403602
SCREW (4)

5 PL 76117
PLATE

6 (see note)
BEARING, center

***7** GA 5264
GASKET (2)

8 WA 1518
WASHER (2)

9 WA 406006
LOCKWASHER (2)

10 SC 400064
SCREW (2)

11 PG 7669
PLUG (6)

12 KN 7610
KNOB (6)

13 SPACER
(as required)

PART #	THICKNESS INCH/MM
SR 7610-1	.050/1.270
SR 7610-2	.054/1.372
SR 7610-3	.058/1.473
SR 7610-4	.062/1.575
SR 7610-5	.066/1.676
SR 7610-6	.046/1.168
SR 7610-7	.048/1.219
SR 7610-8	.052/1.321

PART #	THICKNESS INCH/MM
SR 7610-9	.056/1.422
SR 7610-10	.060/1.524
SR 7610-11	.064/1.626
SR 7610-15	.042/1.067
SR 7610-16	.044/1.118
SR 7610-17	.068/1.727
SR 7610-18	.072/1.829

NOTE: Latest pump housings and camshafts do not allow use of center bearing. If bearing is not to be used, refer to note on page 13 (PG 400760 information)

MODEL APE 6BB 110T 7548A

*Denotes parts included in "Pump & Governor Repair Gasket Kit" KT 76399-2.

ASSY VA 400683
VALVE ASSY, overflow-
including 11 thru 14

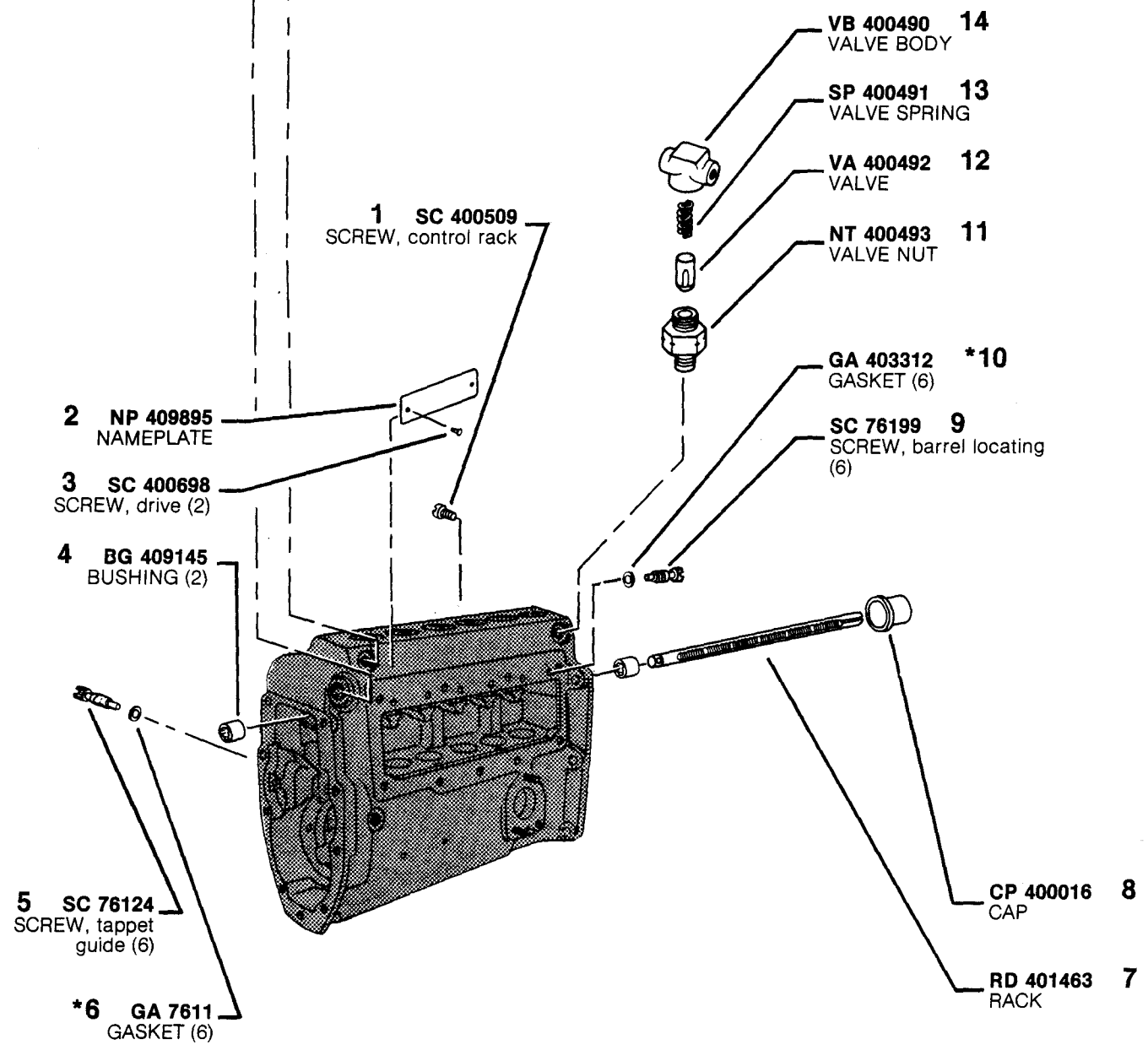

*Denotes parts included in "Pump & Governor Repair Gasket Kit" KT 76399-2.

MODEL APE 6BB 110T 7548A

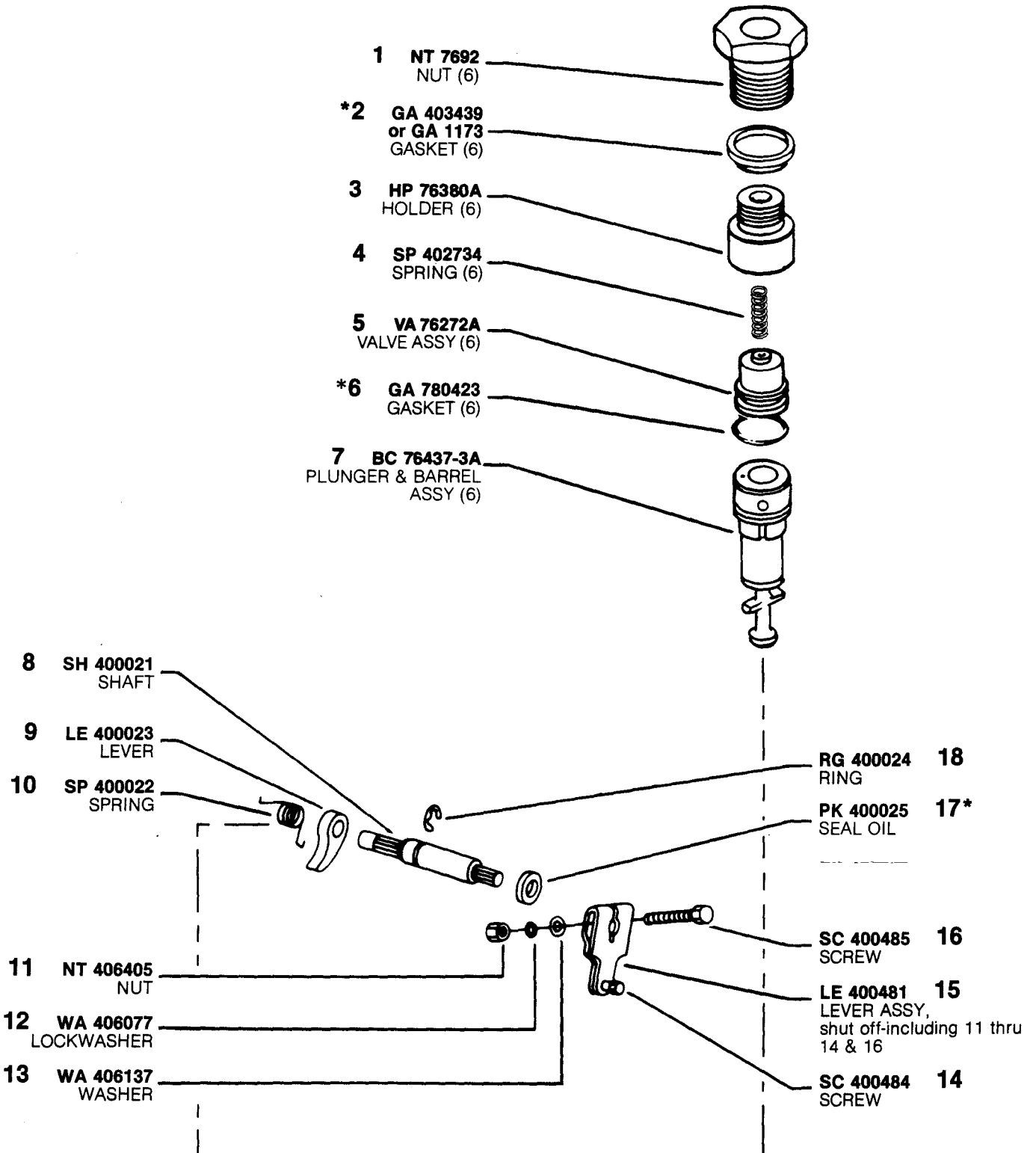

*Denotes parts included in "Pump & Governor Repair Gasket Kit" KT 76399-2.

MODEL APE 6BB 110T 7548A

ASSY SPA 22B2
 PUMP ASSY, supply-
 including 1 thru 9 & 11
 thru 16

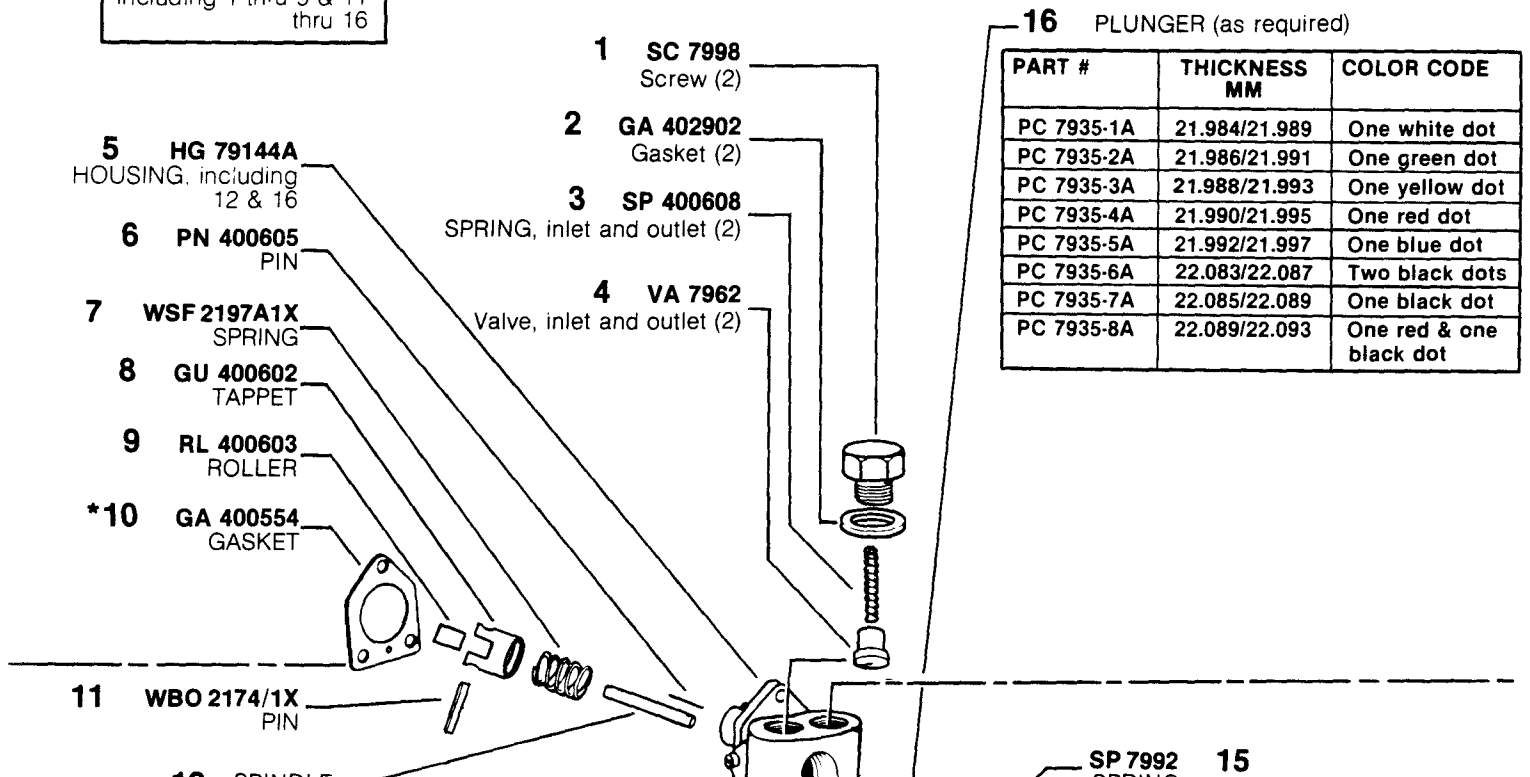

PART #	THICKNESS MM	COLOR CODE
PC 7935-1A	21.984/21.989	One white dot
PC 7935-2A	21.986/21.991	One green dot
PC 7935-3A	21.988/21.993	One yellow dot
PC 7935-4A	21.990/21.995	One red dot
PC 7935-5A	21.992/21.997	One blue dot
PC 7935-6A	22.083/22.087	Two black dots
PC 7935-7A	22.085/22.089	One black dot
PC 7935-8A	22.089/22.093	One red & one black dot

PART #	THICKNESS MM	COLOR CODE
SL 798-1	4.993/4.995	Red — one end
SL 798-2	4.995/4.997	Blue — one end
SL 798-3	4.997/4.999	Yellow — one end
SL 795-1	5.020/5.022	Yellow — one end White — one end
SL 795-2	5.044/5.046	Yellow — one end Black — one end
SL 795-3	5.067/5.069	White — one end Black — one end
SL 798-4	5.087/5.089	White — one end
SL 798-5	5.089/5.091	Black — one end
SL 798-6	5.091/5.093	Green — one end
SL 798-7	5.093/5.095	Aluminum — one end
SL 795-4	5.116/5.118	Aluminum — one end Red — one end
SL 795-5	5.039/5.141	Aluminum — one end Blue — one end
SL 795-6	5.162/5.164	Aluminum — one end Yellow — one end
SL 798-8	5.189/5.191	Red — both ends
SL 798-9	5.191/5.193	Blue — both ends
SL 798-10	5.193/5.195	Yellow — both end
SL 798-11	5.195/5.197	Black — both ends

SPINDLE (requires reaming)

PART #	THICKNESS MM	COLOR CODE
SL 793-1	5.557/5.560	Red & Blue — one end
SL 793-2	5.561/5.564	Red & Green — one end
SL 793-3	5.565/5.568	Red & Yellow — one end
SL 793-4	5.569/5.572	Blue & Green — one end

MODEL APE 6BB 110T 7548A

*Denotes parts included in "Pump & Governor Repair Gasket Kit" KT 76399-2.

ASSY MP 404760
MANUAL PRIMER
 ASSY, including 3 thru 9
 (Optional)

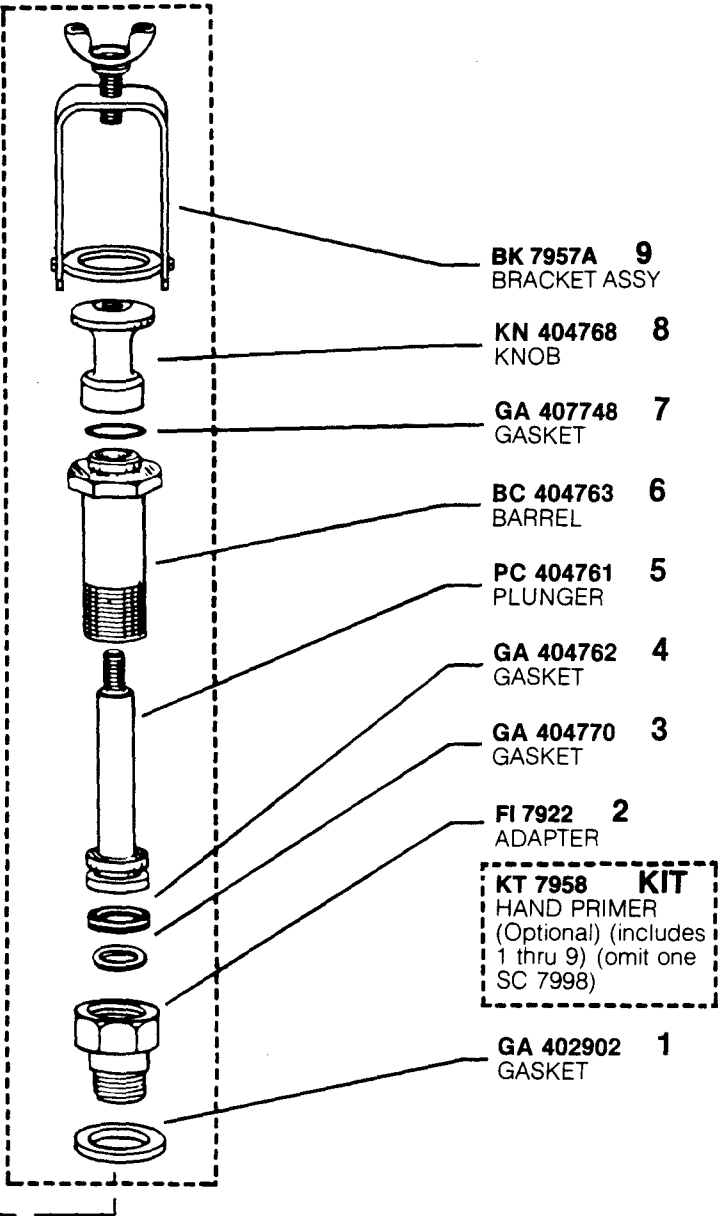

MODEL APE 6BB 110T 7548A

**NOTE ON ELIMINATION OF CENTER BEARING
IN APE 6BB FUEL INJECTION PUMPS****INFORMATION:**

Latest APE 6BB fuel injection pumps do not incorporate center bearings and accordingly, pump housings and cam shafts are no longer machined to provide for use of the part.

For earlier type APE 6BB pumps, elimination of the center bearing is **OPTIONAL**.

CAUTION: Prior to assembly of a camshaft and center bearing to a pump, first determine that the bearing can physically be used. Insure that there are holes in the housing for the bearing retaining screws and that the journal between cam lobes #3 and #4 has been machined to accept the part.

If a housing has been machined to accept a center bearing and the bearing is not to be utilized, then the screw holes must be plugged per the following instructions:

INSTRUCTIONS:

Plug center bearing screw holes as follows:

1. Clean out screw hole counterbores.
2. Press plug, PG 400760 into each hole.
3. Seal plug in hole with Devcon F, or an equivalent epoxy.

NOTE: Elimination of the center bearing is only to be undertaken if the initial service problem required removal of the camshaft from the pump.

THIS NOTE SUPERCEDES MODEL 6BBT, SERVICE BULLETIN S7.

MODEL APE 6BB 110T 7548A