



AR3100 SERIES
INTEGRAL ACTUATOR for STANADYNE "D" SERIES F.I. PUMPS

INTRODUCTION

The AR3100 Series Integral Actuator is designed to mount directly to Stanadyne "D" Series fuel injection pumps. When the AR3100 electric actuator is installed on the fuel pump, an integral high performance fuel control system results. No external linkage or brackets are required and no extra Stanadyne parts are needed. In addition, when the governor system is de-energized, the AR3100 Series electric actuator provides the function of a fuel shut off solenoid.

Ambac International employs its field proven electromechanical design, which provides proportional actuator movement based on actuator coil current.

The AR3100 actuator is simple to install. It conveniently replaces the fuel injection pump mechanical governor cover to achieve an integrated proportional servo fuel control package.

SYSTEM DESCRIPTION

The actuator is an electromagnetic servo device, which can be integrated into a closed loop fuel control system. An engine speed control system can be described as follows: Speed signals which are proportional to engine speed are generated by a magnetic speed sensor. This signal is sent into the electronic speed control unit, which compares it to the preset engine speed setting. If the magnetic speed sensor signal and preset engine speed setting are not equal, a change in current from the speed control unit to the actuator will change the magnetic force to the actuator.

The rotation of the actuator shaft will then adjust the fuel delivery to the engine, which will result in a change to the engine speed, bringing it to the preset engine speed setting. Actuator shaft rotation is proportional to the amount of actuator current and counterbalanced by the actuator's return spring.

Since the design has no sliding parts and is sealed, outstanding reliability results. No maintenance is required.

SPECIFICATIONS

POWER INPUT

Operating Voltage (Dedicated Coil).....	12 or 24 VDC available
Nominal Operating Current.....	1.9 A at 12 VDC
.....	1.5 A at 24 VDC
Maximum Current (Continuous).....	2.7 at 12 VDC
.....	1.9 at 24 VDC

ENVIRONMENTAL

Operating Temperature Range.....	-40 + 180F(-40 to+85C)
Relative Humidity.....	up to 100%
All Surface Finishes.....	Fungus Proof and Corrosion Resistant

PHYSICAL

Dimensions.....	See Diagram 1
Weight.....	2.2lbs(1Kg.)
Mounting.....	Directly on STANADYNE "D" Series fuel injection pumps

RELIABILITY

Testing.....	All units 100% Tested.
--------------	------------------------

MATING HARDWARE

Wiring Harness - (2Wire with Automotive Connector included w/Actuator).....	Available
---	-----------

Diagram 1.

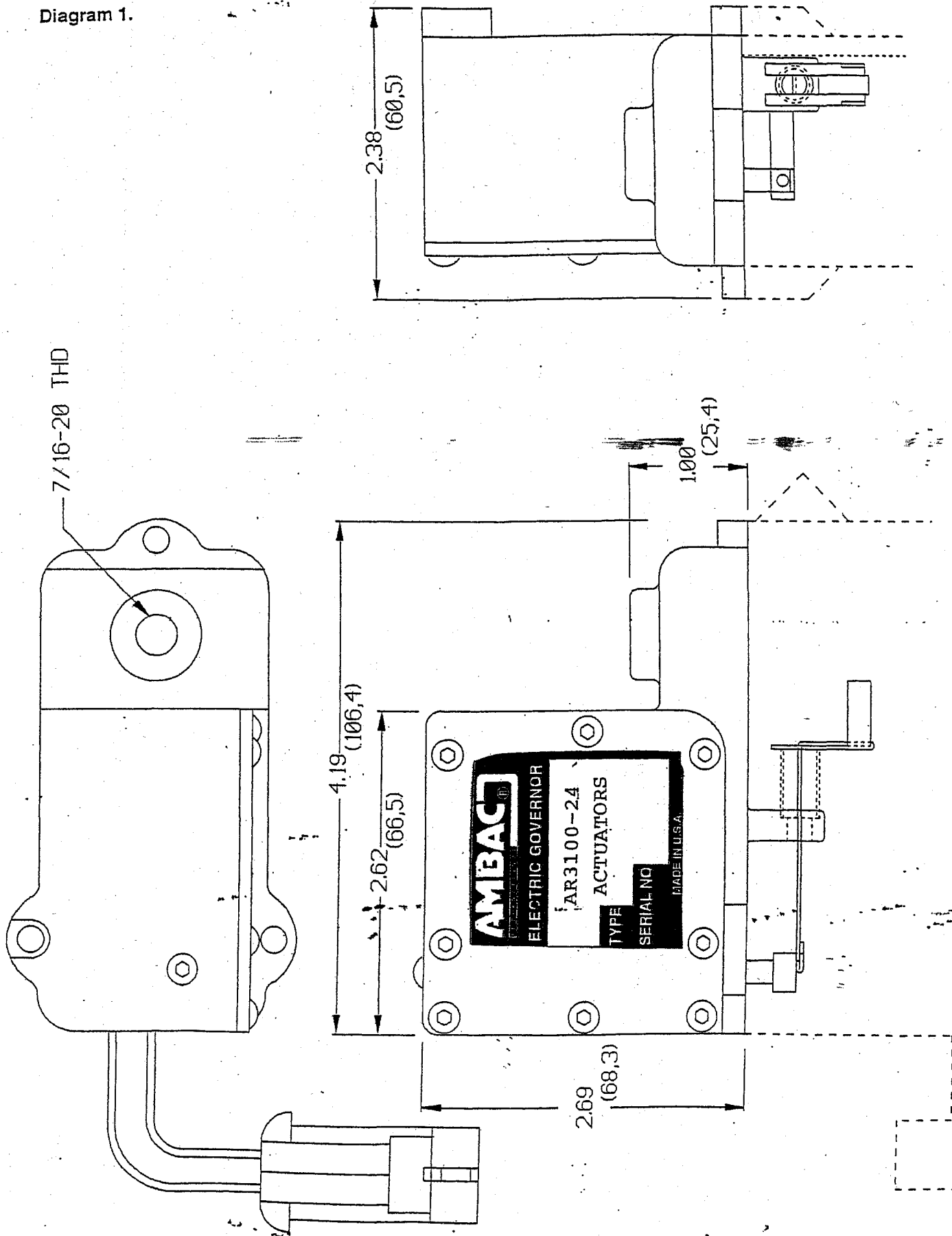

INSTALLATION

PREPARING THE FUEL PUMP

Before the fuel injection pump's Governor Cover can be removed and replaced with the AR3100 Series electric actuator, it is important for the outside of the pump to be clean. If necessary, remove any dirt with a solvent. The cleaning solvent as well as fuel oil can be collected by placing a suitable container underneath the pump.

1. Disconnect the pump's Electric Shutoff Solenoid wire from its connection point on the pump's Governor Cover. This wire is no longer necessary and can be eliminated at its source.
2. Remove the Fuel Return line from the Fuel Return Line Connector.
3. Remove the three (3) Governor Cover Screws. These will be replaced by mounting screws provided with the AR3100 series Actuator.
4. Remove the Governor Cover Assembly with care, to insure that no dirt is allowed to enter the fuel injection pump.
5. Remove the Fuel Return Line connector and the Gasket from the Governor Cover Assembly. Save the Fuel Return Line Connector and Gasket for later assembly use with the AR3100.

INSTALLING THE ACTUATOR

1. Re-install the straight fuel Return Line Connector and original pump Gasket to the AR3100 electric actuator.
2. Position the AR3100 electric actuator on the fuel injection pump with the tall end of the electric actuator tilted slightly upward. See Diagrams 1 and 2.
3. Slide the AR3100 electric actuator toward the rear (injector) end of the fuel injection pump until the actuators 'u'-shaped coupler engages the pump's Governor Linkage Hook. After engagement has been made, align the mounting holes between the electric actuator and the fuel injection pump.

CAUTION: Improper engagement of the actuator coupler to the pump's Governor linkage Hook can cause an engine to overspeed!

4. Securely fasten the AR3100 electric actuator to the fuel injection pump, using the (3) screws provided with the actuator.
5. Reattach the Fuel Return Line to the Fuel Return Line Connector seated on the AR3100 electric actuator.

FUEL INJECTION PUMP SET-UP

Prior to starting the engine, the pump's shut off lever, throttle lever and mechanical governor must be set, to insure compatibility with the electronic governor.

1. Secure the shut off lever in the "ON FUEL" position, if the Stanadyne pump is equipped with one.
2. Lock the throttle lever in the High Idle fuel setting position. This setting should be 10-12% above the desired governor speed.
3. Adjust the pump's mechanical governor Droop by turning the Droop Adjusting Screw counterclockwise (CCW) until it stops. Then turn it clockwise (CW) two turns. This adjustment will provide compatibility between the mechanical governor and the electronic governor. See Diagram 2.
4. Purge the air in the fuel pump by removing the allen head plug located on top of the actuator.

WIRING

The AR3100 Series Actuators are designed to have a specific coil for use in 12 VDC operation, and different specific coil for 24 VDC operation. These actuators are respectively identified as AR3100-12 and AR3100-24. The output from the selected Ambac speed control unit is connected to the AR3100 Series actuator using the Ambac cable harness CH1215. See the specific speed control unit literature for wiring information.

TROUBLESHOOTING

If the governor system fails to operate and the actuator is suspected to be the problem, make the following tests.

Measure Coil Resistance

3.0 ohms	12VDC
7.5 ohms	24VDC

Measure Coil Isolation

>1M ohm to ground

Before removing cover, make sure you have Permatex Blue RTV Silicone to reseal it.

Remove actuator cover and manually move the actuator through its range by depressing the actuator armature. Energize the actuator to full fuel (follow steps in control unit publication) No binding or sticking should occur. Install new cover gasket and replace actuator cover. If the actuator passes these tests, the problem is elsewhere in the governor system. Refer to the speed control unit trouble shooting publication.

Diagram 2.

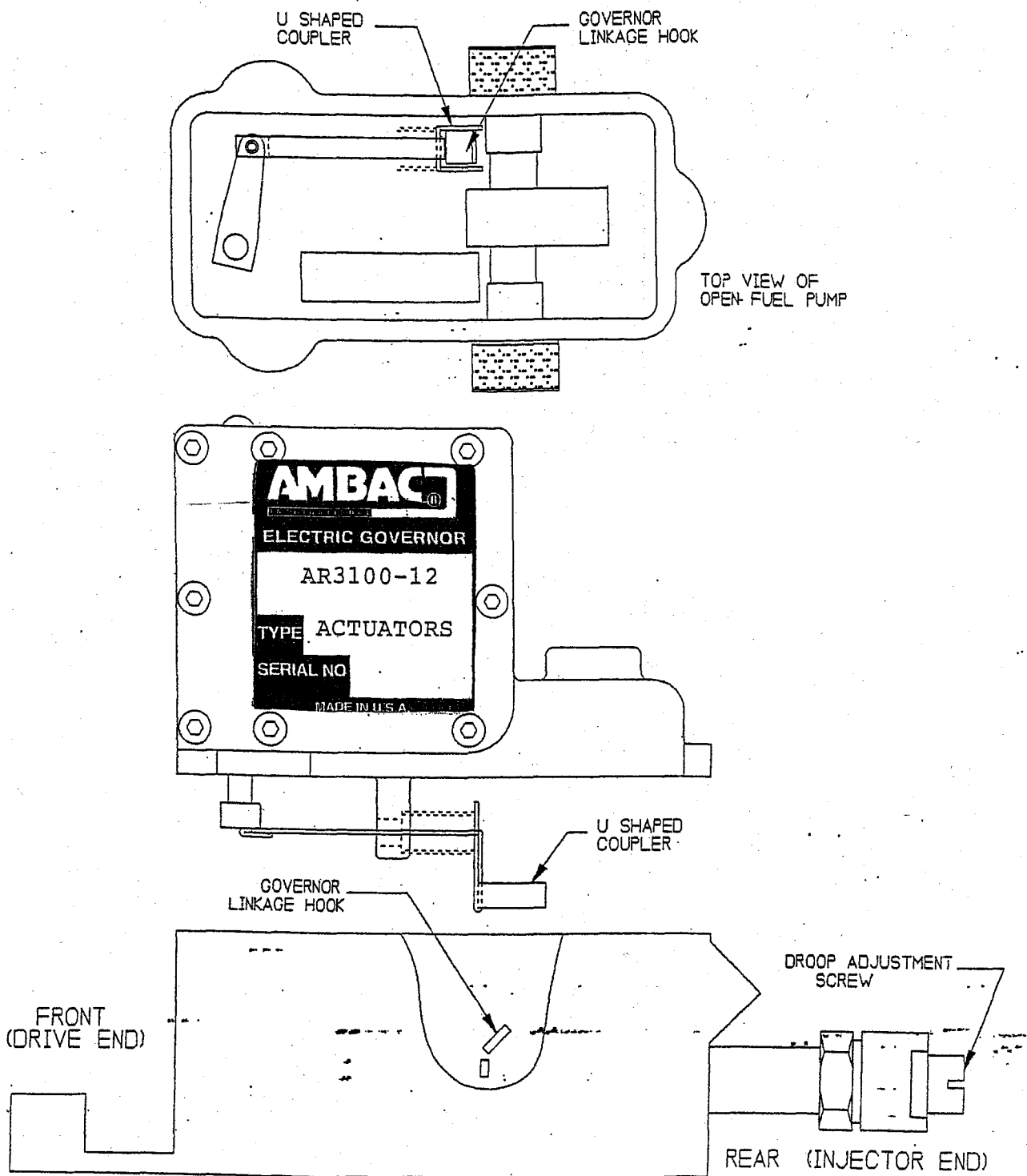

AMBAC INTERNATIONAL *
I77 & KILLIAN RD COLUMIA SC 29202
PHONE 803-735-2191, 800 628-6894.
FAX 803-735-2280, 800-542-8230
E-MAIL ksmith@ambac.net
jadams@ambac.net