



WIRING HARNESS CONNECTIONS

CB 6711A

- 1) Prewire actuator electrical connector to match supply voltage. Crimp connect blue and green wires from control unit connector harness to actuator connector as shown in diagram #1.

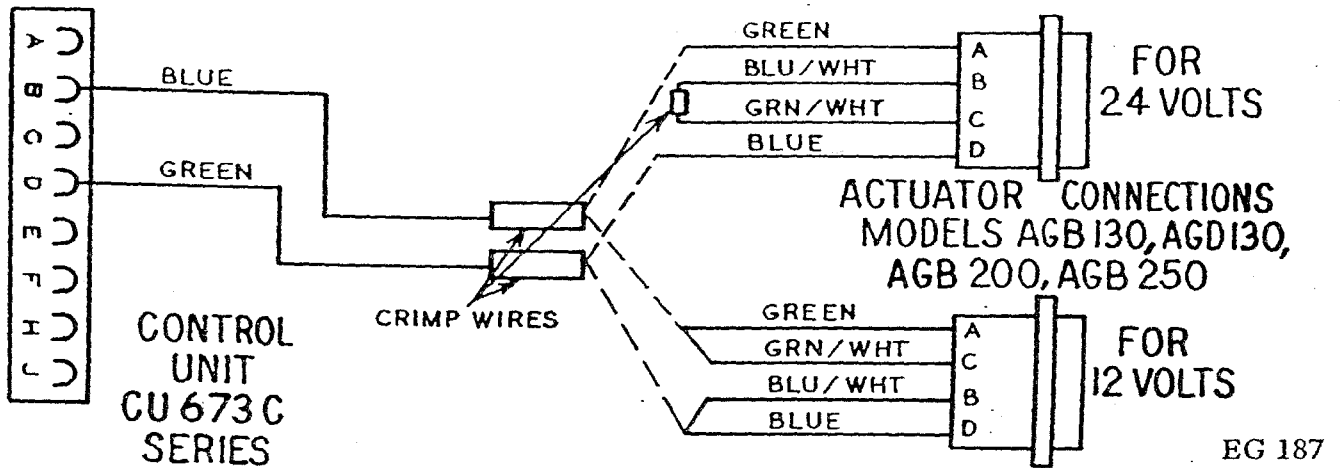

DIAGRAM #1

- 2) Connect magnetic pickup to control unit as shown in Diagram #2.

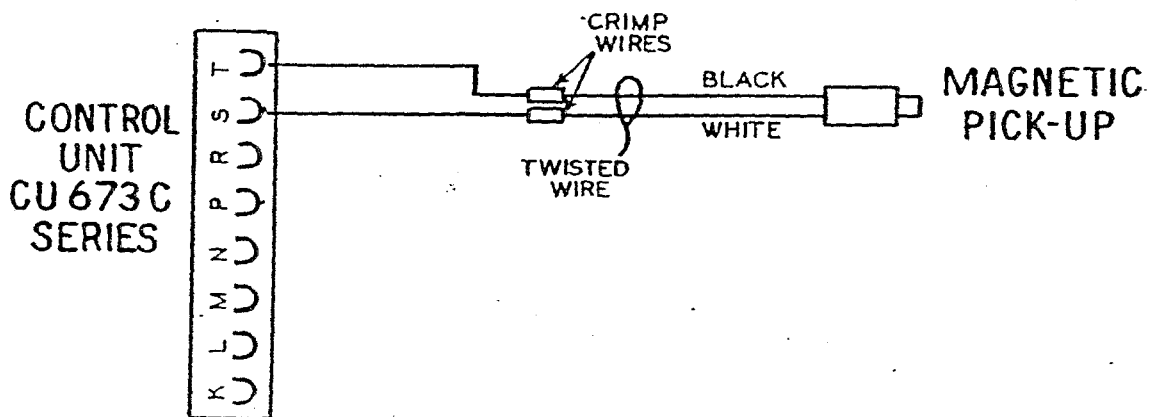

DIAGRAM #2

3) Connect battery leads as shown in Diagram #3 for 12 volt operation. For 24 volt operation, cut orange lead and tape to harness.

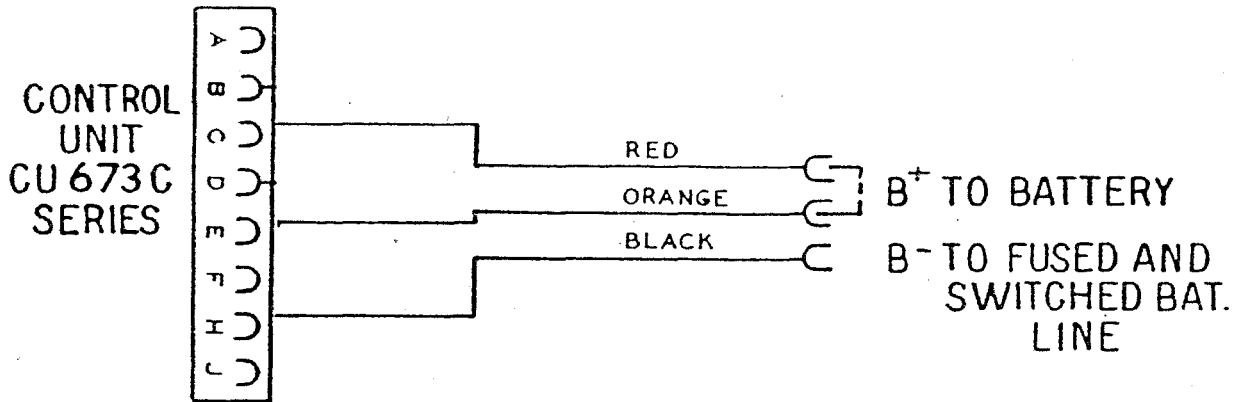

DIAGRAM #3

4) Mount speed trim control potentiometer (CU 6710A) in any convenient location.

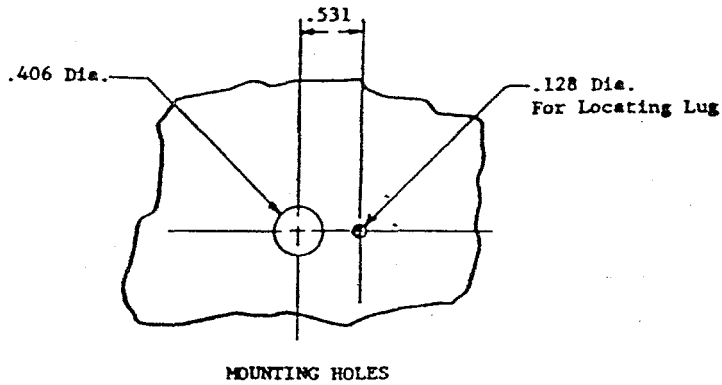

DIAGRAM #4