

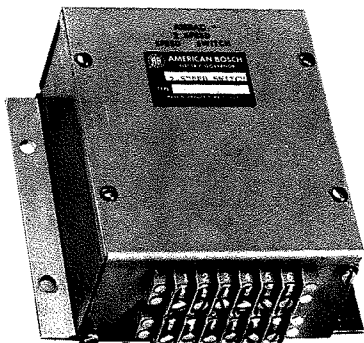

TWO - SPEED SPEED SWITCHES

CU 6717A and CU 6717A-1



EG - 93

INTRODUCTION

This safety switch is a two-speed electronic speed switch. Adjustable low and high speed sections are incorporated for use in controlling cranking termination and overspeed shutdown of an engine. The low speed section also provides a cranking termination feature. Both cranking and overspeed functions are controlled by internal relay contacts for ease of connecting into existing systems. The control speeds are externally adjustable. The difference between the CU 6717A and CU 6717A-1 is as follows:

- A. The CU 6717A provides a timed cranking termination feature, to prevent overcranking. The CU 6717A-1 does not.
- B. The CU 6717A provides loss of pickup protection through the overspeed sensing circuit. The overspeed contacts of the CU 6717A energize when no magnetic pickup signal is received and when engine speed is above the overspeed setting. The overspeed contacts of the CU 6717A-1 energize only when engine speed is above the overspeed setting. However, when the CU 6717A-1 is used in conjunction with the American Bosch speed control unit, loss of pickup protection is provided by the speed control unit.

SPECIFICATIONS

Battery Voltage Range	10-40 V D.C. at 75 MA. (10-18 V requires an external jumper)
Magnetic Pickup Input Signal	.25 V. RMS (Min.) to 30 V. RMS (Max.)
Input Signal Impedance	5 KOhms Min.
Cranking Termination Range	300-2000 Hz. (Approx. 140-900 RPM adjbl)
Overspeed Shutdown Range	1500-10000 Hz. (Approx. 700-4500 RPM adjbl)

Cranking Time (CU 6717A) 30 Sec(s) Nom. depending upon cranking speed

Cranking Time (CU 6717A-1) Indefinite

Relay Contacts SPDT 5 Amp. D.C. (Max.)

Operating Temperature -65°F. to 160°F.

OPERATION

The American Bosch speed switches (CU 6717A and CU 6717A-1) are fast acting 2-speed switches which use a magnetic pickup or other A.C. signal (proportional to speed) as a frequency sensing element. The unit is also fail safe for loss of power and reverse voltage protection. Parallel operation of the magnetic pickup used with the American Bosch electric governor or any magnetic pickup presently in use is acceptable. One side of the magnetic pickup is connected to ground (terminal 11) and a minimum of .25 volts RMS must be maintained.

CU 6717A

The cranking cycle may be initiated two ways; applying power to the unit or momentarily grounding terminal 12 on the unit. The internal relay starting contacts (terminals 4 and 5 normally open) can energize the starter through appropriate solenoids. A single turn potentiometer is used to adjust the cranking termination point, usually set slightly above the known engine cranking speed. Clockwise adjustment increases the termination speed. If termination speed is not attained in about 30 seconds, the cranking cycle will shut down until re-initiated.

A lack of signal before the engine is cranked or magnetic pickup signal is lost causes the overspeed circuit to indicate a speed higher than the maximum permissible operating speed. An internal relay typically used to control fuel solenoids, ignition circuits or other shut-down devices will be de-energized in a position for engine shut down (terminals 1 and 2 normally open, terminals 2 and 3 normally closed). As the engine begins to crank, the overspeed circuit relay resets to the running position and the engine is allowed to start. The engine is now protected against overspeed. An adjustable control is incorporated for adjusting the overspeed setting. If overspeed is attained, the internal relay will energize and latch in this position until the unit is recycled by the starter circuit.

NORMAL RELAY SEQUENCE OF OPERATION
FOR CU 6717A

CONDITIONS

1. No Battery Power to Unit

Overspeed

Cranking Cutoff

Term. 1 & 2 → N.O. Term. 4 & 5 → N.O.
Term. 2 & 3 → N.C. Term. 5 & 6 → N.C.

2. Battery Power Applied to Unit (Engine Not Cranking)

Overspeed

Cranking Cutoff

Term. 1 & 2 → N.O. Term. 4 & 5 → CLOSED
Term. 2 & 3 → N.C. Term. 5 & 6 → OPEN

3. Battery Power Applied to Unit (Engine Cranking, Speed Below Cranking Cutoff Setting)

Overspeed

Cranking Cutoff

Term. 1 & 2 → CLOSED Term. 4 & 5 → CLOSED
Term. 2 & 3 → OPEN Term. 5 & 6 → OPEN

4. Engine Speed Above Cranking Cutoff Setting

Overspeed

Cranking Cutoff

Term. 1 & 2 → CLOSED Term. 4 & 5 → N.O.
Term. 2 & 3 → OPEN Term. 5 & 6 → N.C.

5. Engine Speed Above Overspeed Setting

Overspeed

Cranking Cutoff

Term. 1 & 2 → N.O. Term. 4 & 5 → N.O.
Term. 2 & 3 → N.C. Term. 5 & 6 → N.C.

CU 6717A-1

The cranking cycle may be initiated two ways, applying power to the unit or momentarily grounding terminal 12 on the unit. The internal relay starting contacts (terminals 4 and 5 normally open) can energize the starter through appropriate solenoids. A single turn potentiometer is used to adjust the cranking termination point, usually set slightly above the known engine cranking speed. Clockwise adjustment increases the termination speed. If termination speed is not attained, the cranking cycle will continue until power is removed from the two speed switch.

The overspeed section has an internal relay typically used to control fuel solenoids, ignition circuits or other shutdown devices. The contacts (terminals 1 and 2 normally open, 2 and 3 normally closed) remain in the de-energized position until the overspeed setting is reached. Clockwise adjustment increases the overspeed setting. If overspeed is attained, the internal relay will energize and latch in this position until the unit is recycled by the starter circuit.

NORMAL RELAY SEQUENCE OF OPERATION
FOR CU 6717A-1

CONDITIONS

1. No Battery Power to Unit

Overspeed

Cranking Cutoff

Term. 1 & 2 → N.O. Term. 4 & 5 → N.O.
Term. 2 & 3 → N.C. Term. 5 & 6 → N.C.

2. Battery Power Applied to Unit (Engine Not Cranking)

Overspeed

Cranking Cutoff

Term. 1 & 2 → N.O. Term. 4 & 5 → CLOSED
Term. 2 & 3 → N.C. Term. 5 & 6 → OPEN

3. Engine Speed Above Cranking Cutoff Setting

Overspeed

Cranking Cutoff

Term. 1 & 2 → N.O. Term. 4 & 5 → N.O.
Term. 2 & 3 → N.C. Term. 5 & 6 → N.C.

4. Engine Speed Above Overspeed Setting

Overspeed

Cranking Cutoff

Term. 1 & 2 → CLOSED Term. 4 & 5 → N.O.
Term. 2 & 3 → OPEN Term. 5 & 6 → N.C.

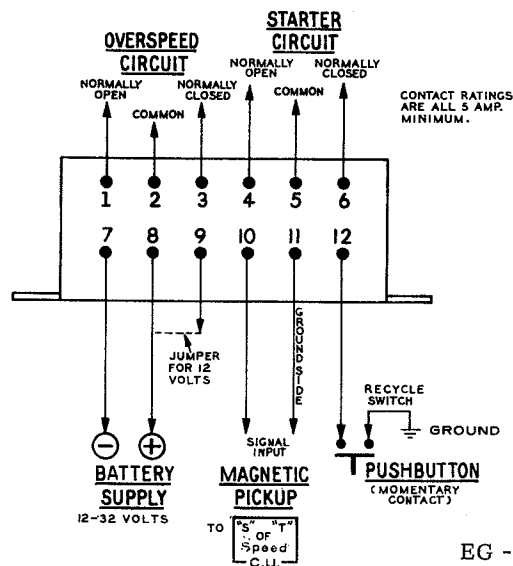

TO INITIATE THE STARTER CIRCUIT APPLY POWER TO THE UNIT OR PUSH RECYCLE SWITCH MOMENTARILY.

CU 6717A & CU 6717A-1
2-SPEED SPEED SWITCHES

EG - 84

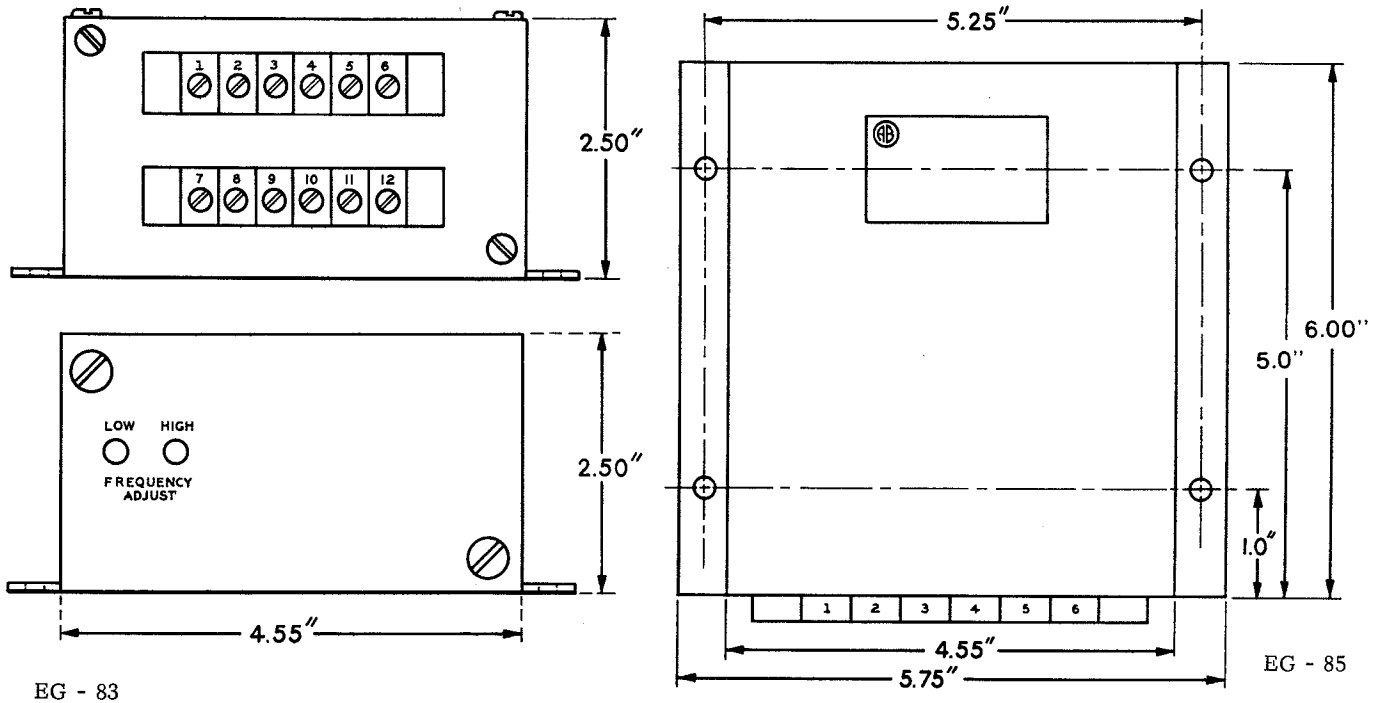

**CU 6717A & CU 6717A-1
2-SPEED SPEED SWITCHES**

