

# ENGINE GOVERNING SYSTEMS

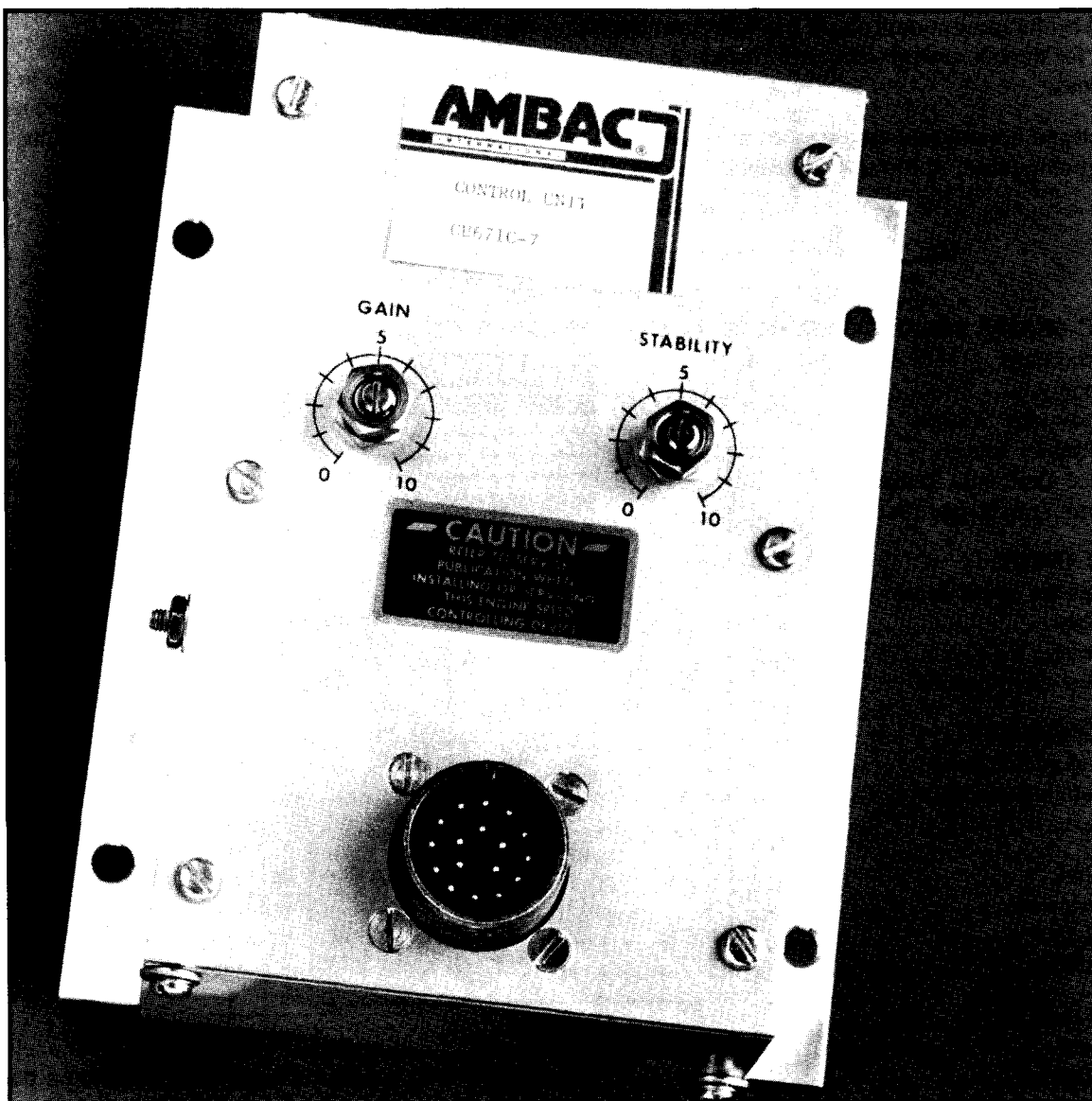

CW 671C

## Speed Control Unit



# ENGINE GOVERNING SYSTEMS



## INTRODUCTION

The speed control unit contains all solid state electronic circuits which sense speed from a magnetic speed sensor or other suitable signal source. A controlled output current is provided by the speed control unit to a proportional electric actuator for throttle control. The performance is isochronous.

Three integral adjustments are provided to achieve the desired performance. A "Frequency Adjust" which can

adjust the speed control range by 30:1, a "Gain" control to increase or decrease governor response sensitivity and a "Stability" control to match the time constant of the governor to that of the engine.

The CW 671C -speed control unit is adaptable to a wide variety of diesel, carbureted gas and gasoline engines, gas turbines, and practically any rotating device that must be speed controlled.

## SPECIFICATIONS

### CW 671C SERIES SPEED CONTROL UNIT PERFORMANCE CHARACTERISTICS

—Isochronous .....	±0.25% regulation or better
—Droop .....	0-5% regulation
—Steady-state Stability .....	±0.25% or better
—Frequency Range .....	300-10K Hz continuous
—Speed Drift with Temperature .....	±1% maximum
—Speed Trim Range (See Note) .....	±200 Hz.

### POWER INPUT

—Magnetic Speed Sensor Signal .....	1.0-30 volts rms
—Supply .....	12-40 VDC (transient and reverse voltage protected)
—Polarity .....	Negative Ground (Case isolated)
—Power Consumption .....	60mA (continuous) plus actuator current

### ENVIRONMENTAL

—Temperature Range .....	-55° to + 85°C (-65° to + 185°F)
—Relative Humidity .....	up to 100%
—Case .....	Fungus proof and corrosion resistant

### PHYSICAL

—Dimensions .....	See Figure 1
—Weight .....	1.13 kgs (2.5 lbs)
—Mounting .....	Any position (See Installation Page 5)

### RELIABILITY

—Tested .....	100%
—Vibration .....	All printed circuit boards are conformally coated on both sides

### WIRING HARNESS AND MATING CONNECTOR (OPTIONAL)

—Wiring Harness .....	CB 679
—Mating Connector Only .....	EC1248-6

NOTE: CW 671C speed is remotely variable over full frequency range. (See Table A)

# ENGINE GOVERNING SYSTEMS

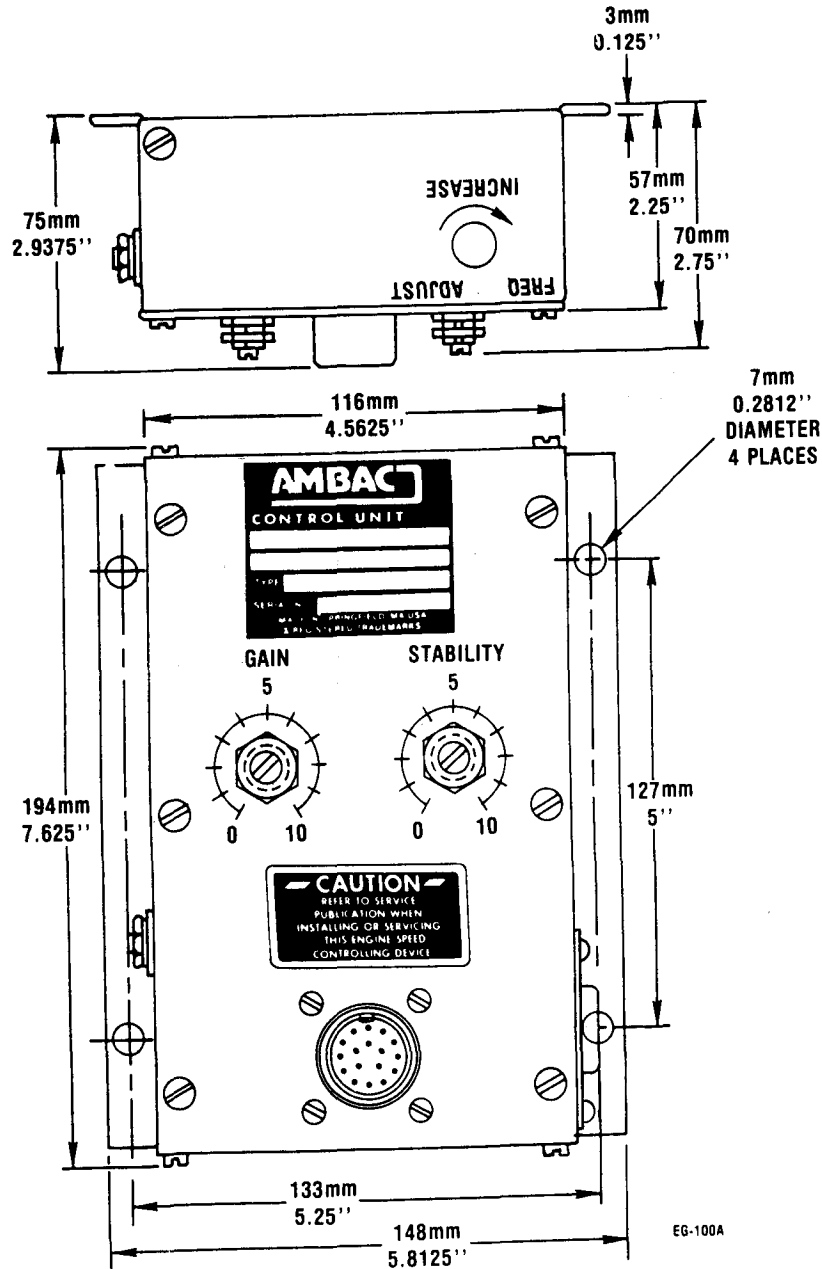

Figure 1. CW 671C speed control unit dimensions

# ENGINE GOVERNING SYSTEMS



## DESCRIPTION

The speed control unit is designed to operate on 12, 24 or 32 VDC systems. For 12 volt operation, one jumper connection is added externally. For 12 volt operation, the speed control unit will operate from 12 to 18 volts. In the 24 - 32 volt connections, the speed control unit will operate from 16 to 40 volts. The speed control unit has sufficient current capacity to handle the AGB, AGK or the AGD actuators.

The speed control unit is available in several types reflected as dash (-) numbers to suit various engine application

needs (see Table A). These variations should be considered when the governor systems are designed.

The speed control unit compares the engine high frequency speed signal with the frequency of the reference oscillator signal. The speed control unit supplies the proper current to the electric actuator which, in turn, controls the engine power to minimize the difference between the frequency of the two signals. (See Figure 2).

### **\*\*ATTENTION\*\***

We have consolidated this product line in order to achieve some production efficiencies and provide aftermarket service parts that meet the needs of our customer. The CW671C-30U has superseded the CU671C-7, CU671C-26, CU671C-17. The CW671C-30U standard amperage is 30 amps at 40 VDC. Please refer to the installation instructions and wire diagram.

### **Pickup Signal and Amplifier**

The engine speed signal is usually obtained from a magnetic speed sensor mounted in close proximity to the teeth of a ferrous gear that is driven by the engine. The frequency of the speed sensor signal is proportional to engine speed. The flywheel ring gear is normally used because of the ease of speed sensor installation and because of the high frequency speed sensor signal.

Other signals may be used for a speed signal instead of the output of the flywheel. The governor will accept any signal if the frequency is proportional to engine speed, and in the frequency range of the governor (300 to 10K Hertz). The signal strength must also be within the range of the input amplifier (1.0 volts rms to 30 volts rms for approximately sinusoidal signals). The input amplifier is very tolerant to signal wave form. It is required only that a non-sinusoidal signal have a minimum of 1.0 volts rms and a maximum of 30 volts rms at all engine speeds from cranking to maximum. The speed control unit has an input impedance

of 5.1 K-ohms between terminal "S" and terminal "T". Terminal "T" is connected internally to the battery negative.

The input amplifier protects the system if the input signal is not strong enough. In the absence of any signal from the magnetic speed sensor, the speed sensor amplifier goes into a local oscillation of about 12K Hertz. Since this frequency is above the maximum reference frequency, the phase detector considers the engine in "overspeed" and the actuator moves to the fuel shutoff position. This provides inherent fail safe protection against loss of speed sensor signal.

Since there is no speed sensor signal with the engine stopped, the oscillation of the speed sensor signal amplifier keeps the actuator in the fuel shut-off position until the engine is cranked. After a few teeth have passed the magnetic speed sensor, enough signal is provided to block the input amplifier oscillation. At this time, the actuator moves to the full fuel position and remains there during starting and acceleration of the engine.

# ENGINE GOVERNING SYSTEMS

# AMBAC<sup>®</sup>

INTERNATIONAL

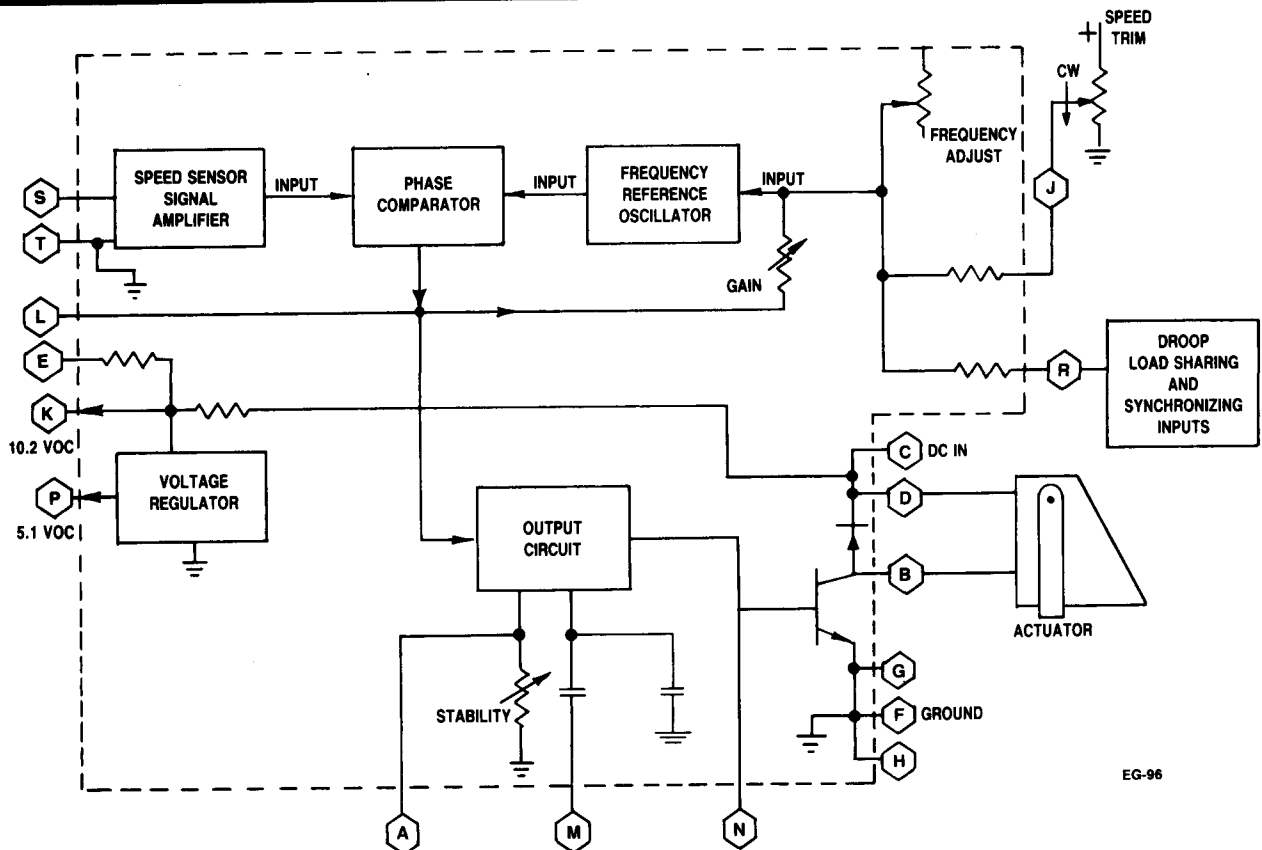

EG-96

Figure 2. Functional Schematic

### Frequency Reference Oscillator

A wide range, temperature compensated, voltage controlled oscillator is used as the speed reference to the speed control system. The frequency setting is adjusted by applying 0 to 10 volts at the frequency reference oscillator input. Zero volts represents a frequency of 10K Hz. while 10 volts represents a frequency of 300 Hz. The internal frequency adjust provides this voltage setting. Use of an external speed trim control enables small adjustments to the reference oscillator ( $\pm 200$  Hz). For a wide range of remote speed control use a CW 671C.

Two external inputs are available to adjust the frequency reference oscillator. Terminal "J" is the input from the speed trim control which provides minor trimming of engine speed. A wide range of speed adjustment is attainable if a CW 671C is used. Terminal "R" is the input from accessories such as load sharing, droop, or automatic synchronizing. When the speed control unit is controlling an engine, the reference oscillator does not maintain a constant frequency but deviates from its nominal RPM which occurs during load changes. The reference oscillator is forced

by the phase comparator to track the engine speed sensor input, described below. Thus, the voltage representing speed error is the amount of voltage required to drive the reference oscillator off frequency as far as the engine is off speed at that moment.

### Phase Comparator Circuit

This circuit is used to force the reference oscillator to track the engine speed sensor signal. The phase comparator circuit detects the phase difference between the input signal through the input amplifier and the signal from the reference oscillator. When the engine changes speed, the signal from the input amplifier changes frequency. The phase comparator circuit measures the amount the engine signal is ahead or behind the reference oscillator signal. Its voltage output is used to force the reference oscillator to the same frequency as the signal from the engine. In this way, the phase comparator output is proportional to the speed error. (When used in this way, the phase comparator and the reference oscillator make up a "Phase Lock Loop"). The gain control is used to couple the phase comparator output to the reference oscillator. By increasing the coupling, for example, a small voltage deviation from the phase comparator corresponds to a large frequency deviation, and vice versa. (See Figure 3).



# ENGINE GOVERNING SYSTEMS

# AMBAC<sup>®</sup>

INTERNATIONAL

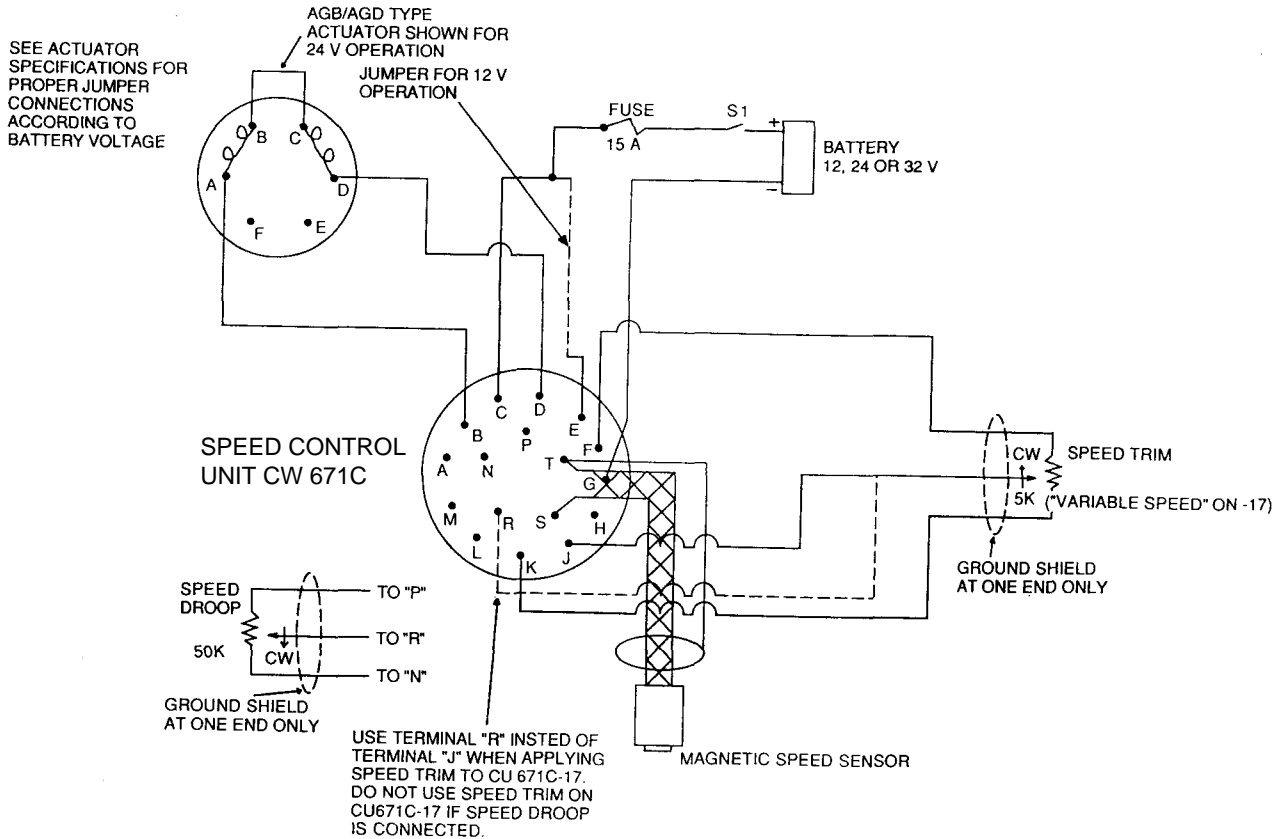

Figure 4. Wiring to CW 671C series speed control unit.

The leads from the battery to the speed control unit and from the speed control unit to the actuator should be #16 or larger. These are the leads that are connected to terminals B, C, D, E and G of the speed control unit.

The leads from the battery to the speed control unit and from the speed control unit to the actuator should be at least #14 if they are over 3 meters (10 ft.). If these leads are over 9 meters (30 ft.) long, they should be at least #12 wire. All other leads may be any convenient size consistent with the mechanical integrity of the cable. Even though the maximum actuator currents exist for only short intervals, the

wiring must be capable of handling this current or the transient performance of the governor will suffer. Connections to terminals "J" and "R" should be shielded. (Fig. 4).

Twist the leads from the magnetic speed sensor for their entire length. The speed sensor leads may need to be shielded if they are longer than 3 meters (10 ft.) or if external interference becomes a problem in governing. The shield is to be grounded **only** to terminal "T" of the speed control unit. Do not ground either of the speed sensor leads.

# ENGINE GOVERNING SYSTEMS



## ADJUSTMENTS

**CAUTION:**  
DO NOT CONNECT THE SPEED CONTROL UNIT  
TO A BATTERY CHARGER

**CAUTION:**  
THE ENGINE SHOULD BE EQUIPPED WITH AN  
INDEPENDENT OVERSPEED SHUTDOWN  
MECHANISM TO PREVENT RUNAWAY WHICH  
CAN CAUSE EQUIPMENT DAMAGE OR  
PERSONNEL INJURY.

### STARTING THE ENGINE INITIALLY

The speed control unit has been adjusted at the factory for starting conditions and will control the engine at approximately idle speed (1000 Hz. speed sensor signal). The following adjustments or checks should be made prior to starting the engine.

- A. Pre-set the gain, stability, and if used, the external speed trim control to their mid-points.
- B. Apply DC power to the engine governing system. The actuator may momentarily move to the full fuel position but then return to the no fuel position.
- C. **MOMENTARILY** connect terminal B to ground (terminal H or battery negative). On CU 671C-7 and -17 only, the large insulated nut at the side of the unit may be used instead of terminal B. This should cause the actuator to snap into the maximum fuel position. If not, check for wiring defects or consult the "Trouble-shooting Section (Page 9)".

Crank the engine. During cranking, the actuator will move the fuel control the maximum fuel position. Once started, the engine will be controlled at a low idle by the engine governing system.

### GOVERNOR SPEED ADJUSTMENTS

Increase the engine speed to the desired governed speed by turning the "speed adjust" control in a CW direction. If used, final precise speed adjustment may be made with the external Speed Trim control. If at any time the engine governing system becomes unstable, turn the gain and stability controls CCW until the engine is stable.

### PERFORMANCE ADJUSTMENTS

Once the engine is at governed speed, the two performance adjustments, gain and stability can be made as follows:

- A. At no load, turn the gain control CW until instability results. Then back-off slightly CCW (one major division) beyond the point where stability returns.
- B. Turn the stability control CW until instability results. Then back-off slightly CCW (one major division) beyond the point where stability returns. Excellent performance should result from these adjustments.
- C. Load may now be applied to the engine. If necessary, repeat A and B above until optimum performance is obtained. Normally, the critical condition for gain and stability adjustment is at no load.

**NOTE:** Optimum adjustment of both controls is in the furthest CW position without causing instability, and will result in the best response and stability under all operating conditions. Backing off slightly from this position will allow for changing conditions that may affect the dynamic response of the engine. If a load bank and a recorder are available, use them to verify the performance using Figure 5 as a guide. If a stable system cannot be obtained, refer to the "Trouble-shooting Section".

The previous procedures should result in a high performance isochronous governed speed control system.

# ENGINE GOVERNING SYSTEMS

# AMBAC

INTERNATIONAL

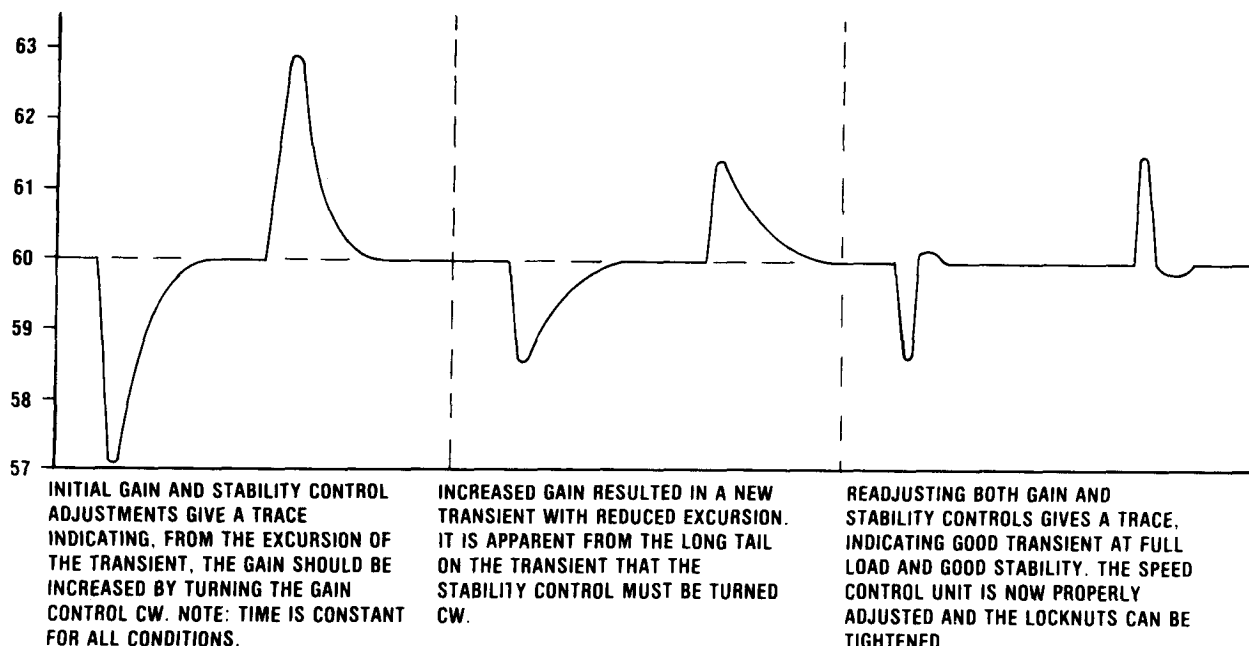

Figure 5. Typical performance chart

## TROUBLESHOOTING

### LOW FREQUENCY INSTABILITY

When low frequency instability or surge (0.5 to 3 Hz.) is experienced, a simple jumper wire connection can be installed between terminal "H" and terminal "M". Older speed control units with serial numbers below 2R 6240 require a polarized, 10 mfd., 10 VDC capacitor to be installed between terminal "M" (+) and terminal "H" (-). This will increase the engine dead time filter compensation and tend to eliminate low frequency instability or surge.

### HIGH FREQUENCY INSTABILITY

When rapid instability or surge (about 8 Hz.) occurs, a jumper connection can be made between terminals "M" and

"N". This will decrease delay compensation and tend to eliminate the instability. For slight instability problems place a 5.1K resistor from terminals M to N.

### UNSATISFACTORY ENGINE PERFORMANCE

When poor transient performance is caused by the speed control unit gain adjustment being at or near its lowest point, a 6.2K ohm resistor can be applied between terminals L and P. This will expand the range of the gain control.

NOTE: Do not install both M to H and M to N jumper connection — no improvement in performance will result.

# ENGINE GOVERNING SYSTEMS



## TROUBLESHOOTING (continued)

If the governor does not operate, measuring, in sequence, voltage between the various speed control unit terminals and ground (Terminals F, G, H and T are ground) will indicate

the possible fault. Should all 5 voltage tests indicate normal values, the defect must be in the actuator or in the wiring to the actuator

TERMINALS	NORMAL VALUE	PROBABLE CAUSE OF NON-NORMAL READING
S	1.0 VAC - RMS minimum while cranking.	<ol style="list-style-type: none"> <li>1. Defective magnetic speed sensor.</li> <li>2. Gap too large between speed sensor and gear teeth.</li> <li>3. Improper or defective wiring to the speed sensor.</li> </ol>
K	10.1 ± 0.20 VDC while energized (Internal regulated DC supply)	<ol style="list-style-type: none"> <li>1. DC power not connected or low battery voltage.</li> <li>2. Speed trim control shorted, ground or miswired.</li> <li>3. Wiring error.</li> <li>4. Defective speed control unit.</li> </ol>
L	<p>Above 5.1 VDC while cranking. (Inverse speed error signal.)</p> <p>Above 5.1 volts is under speed signal. Below 5.1 volts is over speed signal.</p> <p>On speed will indicate a steady 5.1 volts.</p>	<ol style="list-style-type: none"> <li>1. Frequency adjust set too low. Turn CW.</li> <li>2. Defective speed control unit.</li> </ol>
N	8.5 to 9.5 VDC while cranking. (Proportional actuator voltage.)	<ol style="list-style-type: none"> <li>1. Defective speed control unit.</li> <li>2. Battery voltage may be too low while cranking.</li> </ol>
B	2.5 VDC maximum while cranking. (Transistor voltage.)	<ol style="list-style-type: none"> <li>1. Output transistor open (defective speed control unit).</li> <li>2. Defective actuator.</li> <li>3. Error in wiring to actuator.</li> </ol>

## OTHER TROUBLESHOOTING TESTS

SYMPTOM	TEST	PROBABLE TROUBLE
Engine overspeeds	Determine voltage on terminal "L". Should be less than 5.1 VDC.	<ol style="list-style-type: none"> <li>1. Frequency set too high. Turn frequency adjust CCW.</li> <li>2. Defective speed control unit.</li> </ol>
Engine overspeeds	Measure the voltage on terminal "B". Should be more than 2.5 VDC.	<ol style="list-style-type: none"> <li>1. Output transistor shorted. (Defective speed control unit.)</li> <li>2. Wiring to actuator incorrect.</li> </ol>
Throttle does not move	Measure battery voltage at the battery while cranking. Must be at least 75% of nominal battery voltage.	<ol style="list-style-type: none"> <li>1. Insufficient battery voltage. Put a momentary connection from terminal "B" on the control unit to ground (terminal "G") while cranking.</li> <li>2. Replace with battery of higher amp hour rating.</li> </ol>
Throttle does not move	Ground the insulated nut located on the side of the speed control unit. Throttle should move to full open position.	<ol style="list-style-type: none"> <li>1. Wiring to actuator or battery incorrect.</li> <li>2. Actuator or linkage bound.</li> <li>3. Defective actuator.</li> </ol>