

Speed Control Unit



INTRODUCTION

The speed control unit contains all solid state electronic circuits which sense speed from a magnetic speed sensor or other suitable signal source. The pulse from the magnetic speed sensor, which is directly proportional to engine speed, is summed with the speed control unit speed set point. The appropriate current output is supplied to the actuator to control the engine fuel system.

The performance of the speed control unit is isochronous. Speed droop can be selected. A droop control is provided on the speed control unit. The speed range is 6:1 and is adjustable via a 22 - turn speed adjust control.

Only two governor system performance adjustments are needed to achieve optimum performance. A gain control to adjust the governor system's response and a stability control

to match the time constant of governor system to the engine. All adjustments are accessible from the front cover.

The speed control unit also includes the special feature of speed anticipation to minimize speed overshoot on engine start-up or from lug-down. Engine idle feature is selectable which may be utilized for engine warm-up or maintenance.

Wide tolerances of speed sensor input signals and DC supply voltages can be accepted by this speed control unit. In case of loss of speed sensor signal or DC supply voltage, failsafe features are built-in to provide engine shutdown. Reverse voltage polarity protection is provided at battery input.

The ECD 67-5111 speed control unit is adaptable to a wide variety of Diesel, carbureted gas and gasoline engines requiring governed speed control.

SPECIFICATIONS

ECD 67-5111 SPEED CONTROL UNIT PERFORMANCE CHARACTERISTICS

—Isochronous	±0.25% regulation or better
—Droop	0-5% regulation
—Steady-state Stability	±0.25% or better
—Frequency Range	1K-6K Hz continuous
—Frequency Range (Idle)	1K-2.9K Hz maximum
—Speed Trim Range	±200 Hz.
—Speed Drift with Temperature	±1% maximum

POWER INPUT

—Magnetic Speed Sensor Signal	1.0-30 volts rms
—Supply	12 - 40 VDC (transient and reverse voltage protected)
—Polarity	Negative Ground (Case isolated)
—Power Consumption	90mA (continuous) plus actuator current
—Maximum Controllable Actuator Current at 25°C (77°F)	7 Amps

ENVIRONMENTAL

—Temperature Range	-40° to + 85°C (-40° to + 185°F)
—Relative Humidity	up to 100%
—Case	Fungus proof and corrosion resistant

PHYSICAL

—Dimensions	See Figure 1
—Weight	0.51 kgs (1.1 lbs)
—Mounting	Any position (See Installation Page 4)

RELIABILITY

—Tested	100%
—Vibration	All printed circuit boards are conformally coated on both sides

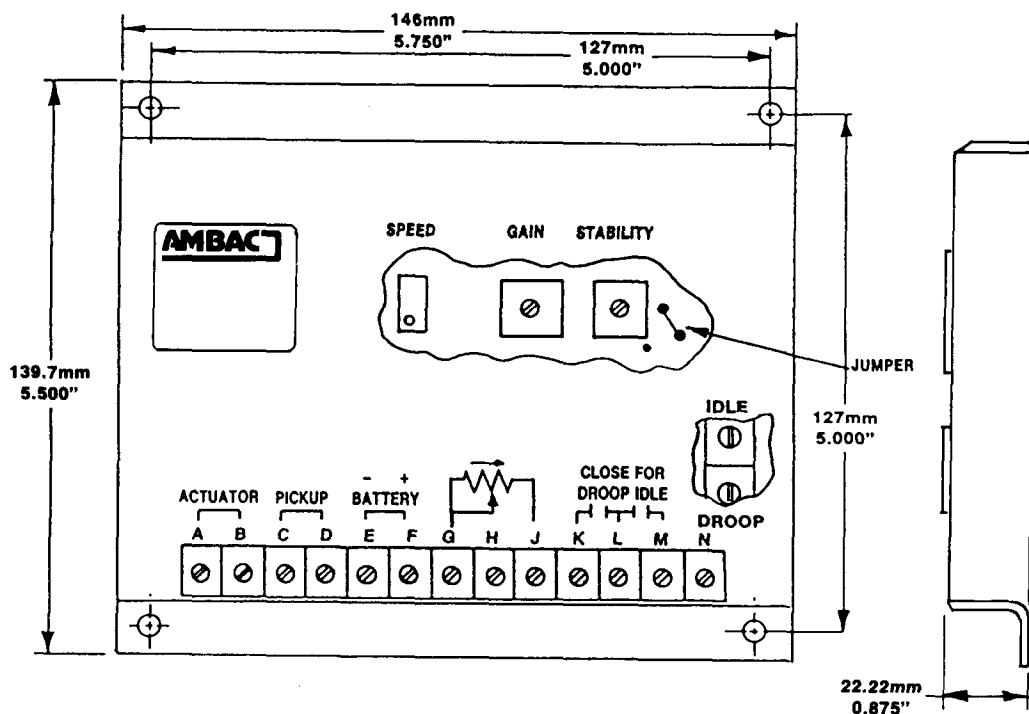

Figure 1. ECD 67-5111 Speed Control Unit Dimensions

DESCRIPTION

The speed control unit circuits are designed to operate directly from a 12, 24 or 32 VDC battery system. An internal 10 volt regulator supplies all DC power to the speed control circuits. The speed control unit has sufficient current capacity to handle all actuators.

The engine speed signal is usually obtained from a magnetic speed sensor mounted in close proximity to the teeth of a ferrous gear that is driven by the engine. The frequency of the speed sensor signal is proportional to the engine speed.

The flywheel ring gear is normally used because of the ease of speed sensor installation and because of the high frequency speed sensor signal. Other speed sensors may be used for a speed signal. The governor will accept any signal if the frequency is proportional to the engine speed, and in the frequency range of the governor (1K to 6K Hz).

The signal strength must also be within the range of the input amplifier (1.0 volts rms to 30 volts rms for approximately sinusoidal signals). When a magnetic speed sensor is used, it is connected to terminals C and D which have an input impedance of 20 K-ohms. Terminal D is connected internally to the battery negative.

The speed sensor signal is amplified and shaped by the circuit to form constant width pulses. The average voltage of these pulses from the speed sensor amplifier section of the speed control unit is then fed to a summing circuit (see Figure 2).

A speed sensor monitor circuit detects the pulses and, if the pulses disappear for longer than 0.1 second, the speed control unit will turn off the output circuit (current to actuator).

During cranking, the actuator will move to full load position and remain there during starting and acceleration of the engine. The summing point of the speed sensor and the speed adjust control is the input to the dynamic control section of the governor.

A gain control is provided to adjust the governor sensitivity. The gain is usually advanced (CW) as far as possible for best performance without instability. (See adjustment procedure).

The stability control is used to match the time constant of the governor to that of the engine.

ENGINE GOVERNING SYSTEMS

AMBAC

INTERNATIONAL

ECD 67-5111

SECTION EG 50-2A

The output actuator current switching circuit provides current to drive the actuator. The output transistor is alternately switched off and on at a frequency of 450 Hz, which is well beyond the natural frequency of the actuator, hence no visible motion from the switching results. The actuator responds to the average current to position the engine throttle. The output transistor is switched to reduce its

internal power dissipation. The output of the circuit provides up to 12 amps instantaneously at voltages up to 40 VDC. The output is suitable to drive AMBAC International actuators or a similar proportional electric actuator. Excellent start-up performance is assured via a speed anticipation circuit which minimizes the overshoot of speed on start-up.

TYPE	VARIATION	APPLICATION
ECD 67-5118	<ul style="list-style-type: none"> Higher Frequency Range <ul style="list-style-type: none"> Frequency Range 1K - 7.5K Hz continuous Frequency Range Idle 1K - 3.9K Hz maximum Speed Trim Range ± 400 Hz 	Engines with higher than normal rpm

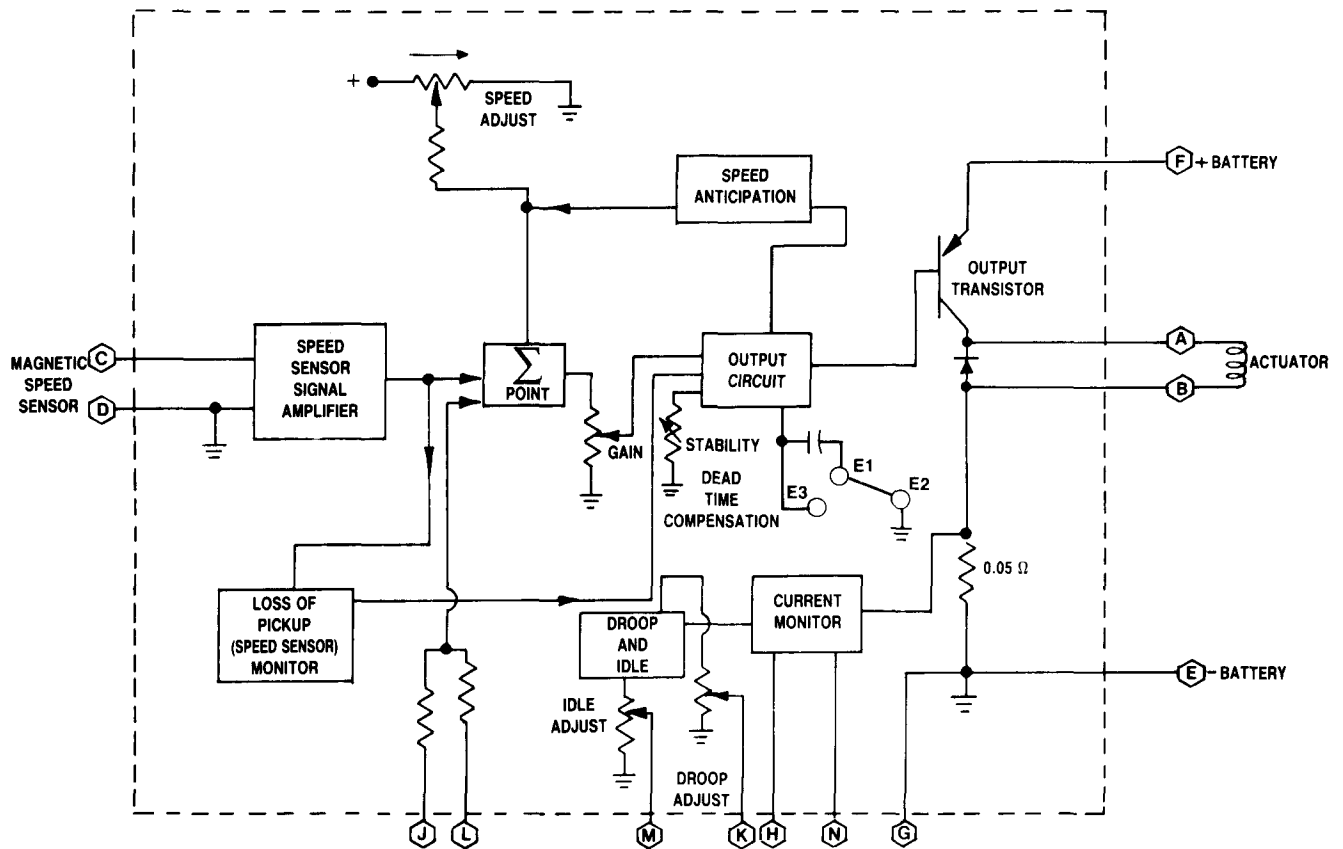

Figure 2. Functional schematic

INSTALLATION

The speed control unit is rugged enough for mounting in the control cabinet or engine mounted enclosure. Care should be taken to insure that the speed control unit is not subjected to extreme heat, as the life of electronic devices is always related to heat. If it is expected that water or mist will come in contact with the speed control unit, mount it vertically so the condensation will not accumulate in the speed control unit.

Wiring to the speed control should be as shown in Figure 3. Leads to the battery and the actuator from the speed control unit should be #16 or larger. These are the leads that are connected to terminals A, B, E and F of the speed control

unit. An external fuse or circuit breaker is recommended in series with terminal F, the positive (+) battery input terminal. The magnetic speed sensor leads are twisted and/or shielded for their entire length. Connect leads to terminals C and D. Connect the shield to terminal D only. Do not connect the shield at the speed sensor end.

Actuator connections should be made according to the actuator publications. For 12 volt operation, or on any actuator larger than an AGB 130 when operating in droop control, jumper terminals H to N on speed control units with serial numbers above 2L23000.

ADJUSTMENTS

CAUTION:
THE ENGINE SHOULD BE EQUIPPED WITH AN INDEPENDENT OVERSPEED SHUTDOWN MECHANISM TO PREVENT RUNAWAY WHICH CAN CAUSE EQUIPMENT DAMAGE OR PERSONNEL INJURY.

CAUTION:
DO NOT
CONNECT THE SPEED CONTROL UNIT TO A BATTERY CHARGER.

STARTING THE ENGINE INITIALLY (See Fig. 3)

The speed control unit has been adjusted at the factory for starting conditions and will control the engine at approximately idle speed (1000 Hz. speed sensor signal). The following adjustments or checks should be made prior to starting the engine.

- Pre-set the gain, stability, and if used, the external speed trim control to their mid-points.
- Apply DC power to the engine governing system thru the wiring system by closing the switch S1. The actuator may momentarily move but should remain in the no fuel position.
- For speed control units with serial numbers below 2L23000, momentarily connect terminal A to terminal E. For speed control units with serial numbers above 2L23000, momentarily connect terminal A to terminal F. This should cause the actuator to snap into the maximum fuel position. If not, check for wiring defects or consult the "Trouble-shooting" Section (Page 7).

Crank the engine. During cranking, the actuator will move the fuel control to the maximum fuel position. Once started, the engine will be controlled at a low idle by the engine governing system.

GOVERNOR SPEED

Increase the engine speed to the desired governed speed by turning the "speed adjust" control in a CW direction. If used, final precise speed adjustment may be made with the external Speed Trim control. If at any time the engine governing system becomes unstable, turn the gain and stability controls CCW until the engine is stable.

PERFORMANCE

Once the engine is at governed speed, the two performance adjustments, gain and stability, can be made as follows:

- At no load, turn the gain control CW until instability results. Then back-off slightly CCW (1/8 turn) beyond the point where stability returns.
- Turn the stability control CW until instability results. Then back-off slightly (1/8 turn) beyond the point where stability returns. Excellent performance should result from these adjustments.
- Load may now be applied to the engine. If necessary, repeat A and B above until optimum performance is obtained. Normally, the critical condition for gain and stability adjustment is at no load.

NOTE: Optimum adjustment of both controls is in the furthest CW position, without causing instability and will result in the best response and stability under all operating conditions. Backing off slightly from this position will allow for changing conditions that may affect the dynamic response of the engine. If a load bank and a recorder are available, use them to verify the performance using Figure 4 as a guide. If a stable system cannot be obtained, refer to the "Trouble-shooting Section, Page 7".

The previous procedures should result in a high performance isochronous governed speed control system.

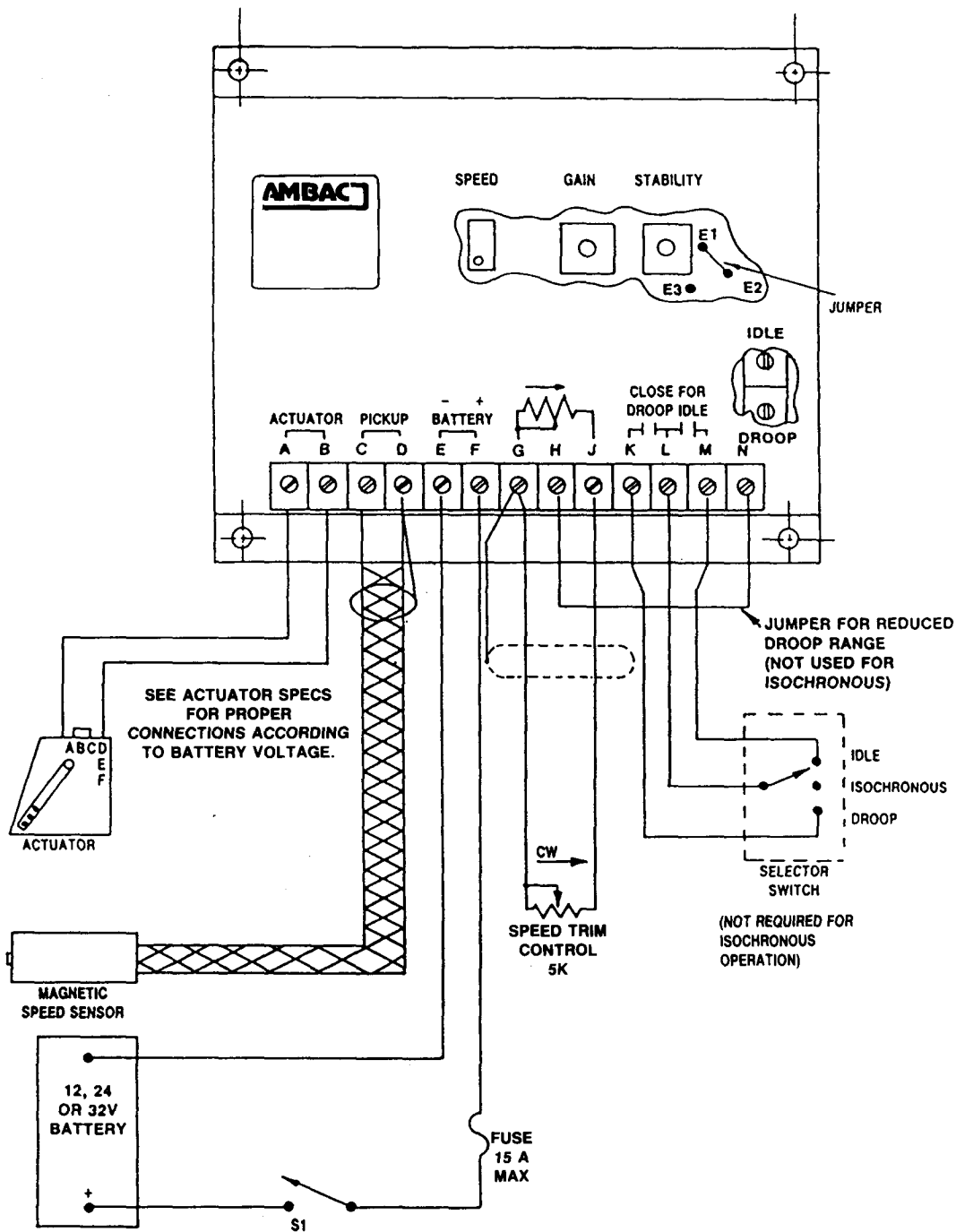

* NOTE: A SHIELDED CABLE SHOULD BE USED IF LEADS ARE LONGER THAN 3 METERS (10 FT.). GROUND SHIELD AT ONE END ONLY.

Figure 3. Wiring to ECD 67-5111 Speed Control Unit

ECD 67-5111

SECTION EG 50-2A

IDLE SPEED SETTING

Place the external selector switch in the idle position. Adjust the idle adjustment of the speed control unit for ideal engine idle speed. CW rotation increases idle speed setting on speed control units above SN 2L23000.

SPEED DROOP

Place the external selector switch in the droop position. An adjustment range of 0.2 to 5% can be obtained. CW rotation increases droop.

If engine speed with droop is lower than desired, turn the speed adjust control CW to increase the engine speed. If used, fine tuning of engine speed can then be obtained by turning the speed trim control.

An external jumper between terminals "H" and "N" will decrease the droop range to allow for 2% droop at 50 Hz.

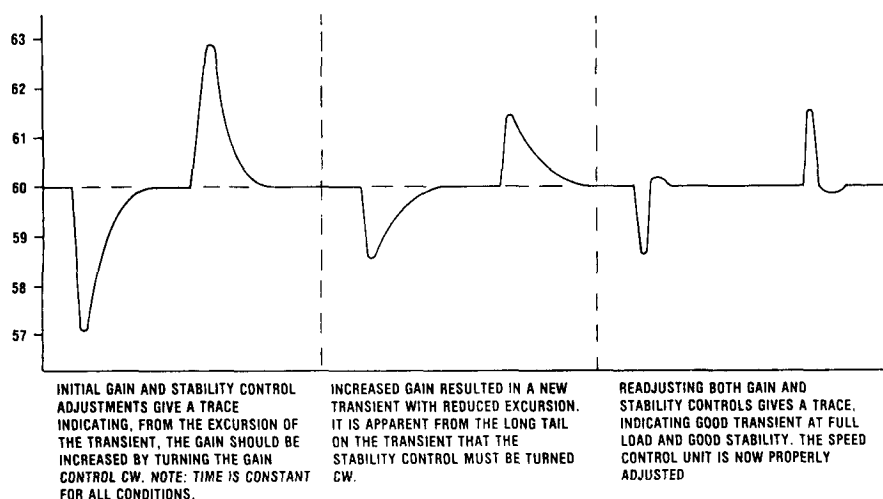

Figure 4. Typical performance chart

Low Frequency Instability

When low frequency instability or surge (0.5 to 3Hz) is experienced, a 10 microfarad (10V, polarized) capacitor may be connected from post E3 (+) to post E1 or E2 (-) (see Figure 3). The jumper between posts E1 and E2 must be left installed.

Dead time is the time between power strokes plus fuel system delays which can cause slow periodic oscillations when the dead time becomes excessive. Addition of capacitance, as described above, increases the dead time compensation of the governor.

High Frequency Instability

When rapid instability or surge (about 8 Hz) occurs, removing the jumper at the stability control (see Figure 3) should eliminate this problem.

Electrical Noise or Unwanted Droop

If noisy electrical devices are present, such as magnetos, solid state ignition systems, battery chargers or regulators which emit radio frequency interference (RFI), then unstable governing or droop may be noticed. The speed control unit has internal filters which provide some protection from radio frequency interference. Excessive levels of RFI must be treated separately. A metal shield placed around the emitting source and/or placing the governor harness and speed control unit as far away as possible from the RFI emitting source will help. Always twist the leads from the magnetic speed sensor all the way back to the speed control unit. When extreme RFI is encountered, it may be necessary to shield all the leads to the speed control units. These shields must be grounded at terminal D or E of the speed control units.

TROUBLESHOOTING

SPEED CONTROL UNITS WITH SERIAL NUMBERS ABOVE SN 2L23000

SYSTEM INOPERATIVE

If the engine governing system does not operate, the fault may be found by performing the following tests. Should all

three voltage tests indicate normal values, the defect must be in the actuator or the wiring to the actuator.

STEP	TERMINALS	NORMAL VALUE	PROBABLE CAUSE OF ABNORMAL READING
1	C & E	1.0 VAC RMS minimum while cranking	1. Defective magnetic speed sensor. 2. Gap between speed sensor and gear tooth too large. 3. Improper or defective wiring to the speed sensor.
2	F & E	12, 24 or 32VDC (Battery Voltage)	1. DC power not connected or low battery voltage. 2. Wiring error.
3	F & A	2.5 VDC maximum while cranking	1. "Speed adjust" set too low. Turn CW. 2. Error in wiring to actuator. 3. Defective speed control unit. 4. Defective actuator.

UNSATISFACTORY SYSTEM OPERATION

SYMPTOM	TEST	PROBABLE TROUBLE
Engine overspeeds	Measure the voltage between terminals A and F on the speed control unit	1. If the voltage is 1.5 to 2.5 volts a) Frequency set too high, turn "speed adjust" CCW b) Defective speed control unit. 2. If the voltage is over 2.5 volts a) Fuel metering valve or linkage sticking. 3. If voltage is below 1.5 volts a) Shorted output transistor. Defective speed control unit.
Actuator does not fully open	1. Measure the voltage at the battery while cranking. It must not be less than 75% of nominal battery voltage. 2. Momentarily connect terminal A to F. The actuator should move to the full fuel position.	1. Replace the battery if it is defective. If it is undersized, replace the battery with one with a proper rating. 2. a) Wiring to the actuator or the battery is incorrect. b) Actuator sticking. c) Defective actuator.
Engine stays at idle		Fuel pump throttle lever not at full fuel position when operating on other than throttle lever.

Insufficient Magnetic Speed Sensor Signal

Although the speed control unit will govern well on 1.0 volts RMS signal if it is a clean sine wave, a signal from the magnetic speed sensor of 3 volts RMS at governed speed will eliminate any possibility of missed or extra pulses.

This signal is measured at terminals C and D. Raise the magnetic speed sensor voltage by reducing the gap between the speed sensor and the ring gear to not closer than 0.75mm (0.030 in.). This is equivalent to backing the speed sensor out by ¼ turn after it touches the ring gear tooth.

Low Frequency Instability

When low frequency instability or surge (0.5 to 3Hz) is experienced, a 10 microfarad (10V, polarized) capacitor may be connected from post E3 (+) to post E1 or E2 (-) (see Figure 3). The jumper between posts E1 and E2 must be left installed.

Dead time is the time between power strokes plus fuel system delays which can cause slow periodic oscillations when the dead time becomes excessive. Addition of capacitance, as described above, increases the dead time compensation of the governor.

High Frequency Instability

When rapid instability or surge (about 8 Hz) occurs, removing the jumper at the stability control (see Figure 3) should eliminate this problem.

Electrical Noise or Unwanted Droop

If noisy electrical devices are present, such as magnetos, solid state ignition systems, battery chargers or regulators which emit radio frequency interference (RFI), then unstable governing or droop may be noticed. The speed control unit has internal filters which provide some protection from radio frequency interference. Excessive levels of RFI must be treated separately. A metal shield placed around the emitting source and/or placing the governor harness and speed control unit as far away as possible from the RFI emitting source will help. Always twist the leads from the magnetic speed sensor all the way back to the speed control unit.

When extreme RFI is encountered, it may be necessary to shield all the leads to the speed control units. These shields must be grounded at terminal D or E of the speed control units.