

- (11) Lift out the hydraulic head assembly carefully to prevent damage to the housing bore. Remove the lower gasket which may be stuck to the lower part of the head or in the housing bore.
- (12) Remove the tappet assembly from the pump housing bore.

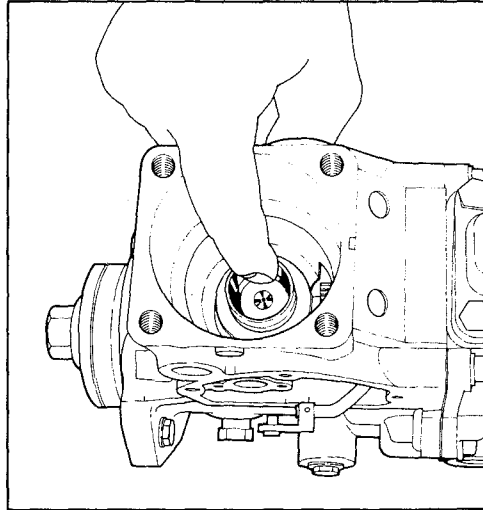

**FIGURE 1-15
REMOVING TAPPET ASSEMBLY**

- (13) Next, remove the roller from the housing bore. Use of a pencil magnet will facilitate removal.

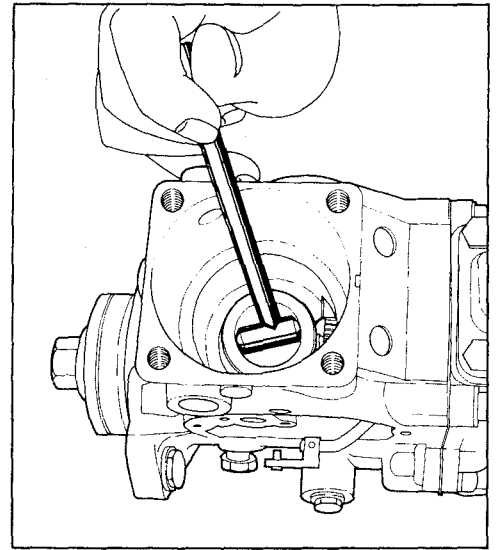

**FIGURE 1-16
REMOVING TAPPET ROLLER**

B. Disassembly of Hydraulic Head

- (1) Remove button retaining ring with a thin awl or scribe.

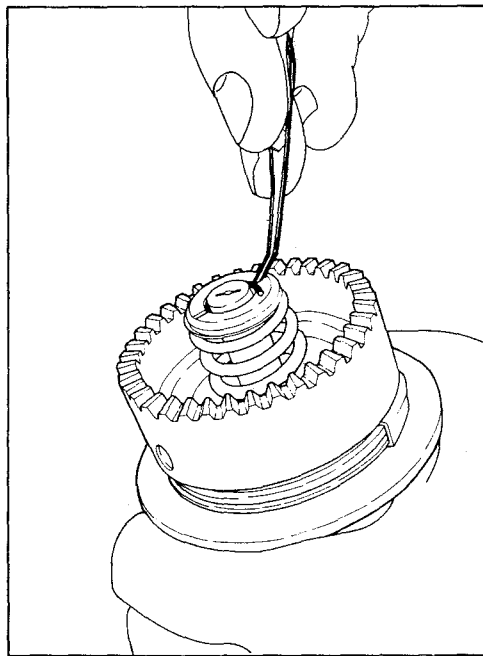

**FIGURE 1-17
REMOVING BUTTON RETAINING RING**

- (2) Next, remove plunger button from bottom of plunger. (Use thin awl or scribe if button adheres to lower plunger).

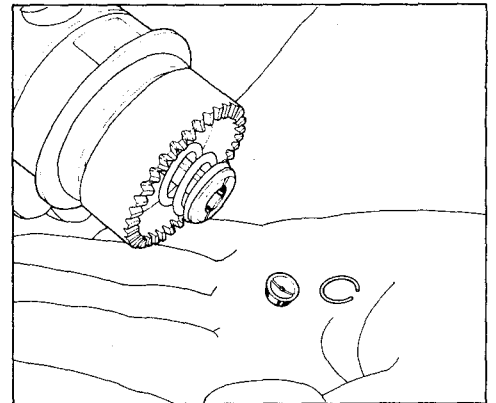
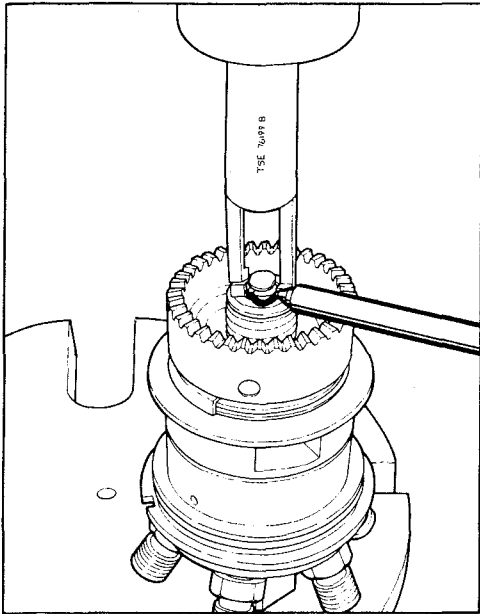

**FIGURE 1-18
REMOVING PLUNGER BUTTON**

- (3) Invert the hydraulic head assembly and place it on a suitable arbor press. Position Service Tool TSE 76199B on lower spring seat.

Caution: Make certain head and tool are centered and straight before depressing spring to avoid damaging head.

- (4) Depress lower spring seat and spring and remove the two half retaining rings with a magnet or tweezers.



**FIGURE 1-19
REMOVING SEGMENT RINGS FROM
LOWER PLUNGER**

Note: It may be necessary to raise the plunger slightly, when spring is depressed, with a screw driver blade in order to remove the retaining rings.

- (5) Remove the lower spring seat and spring.

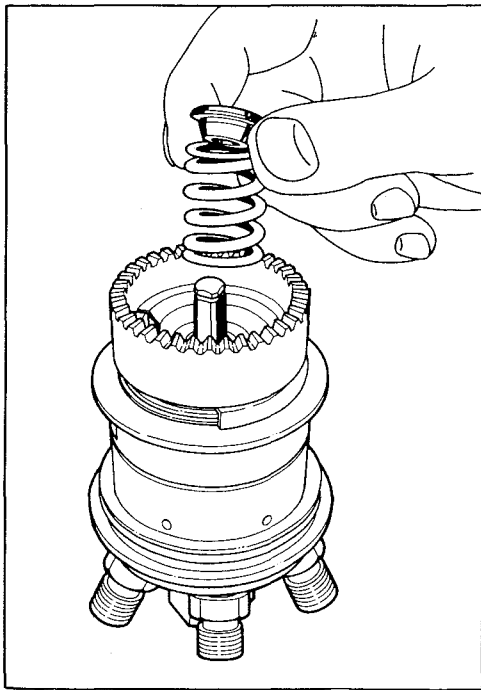

**FIGURE 1-20
REMOVING SPRING SEAT AND
PLUNGER SPRING**

- (6) Remove the washer from the recess in the face gear.

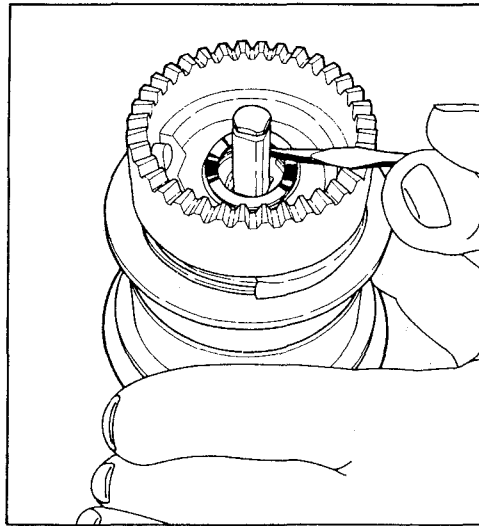

**FIGURE 1-21
REMOVING PLUNGER SPRING WASHER**

- (7) Place hydraulic head on a **clean bench** (or **clean cloth**). Remove face gear retaining ring.

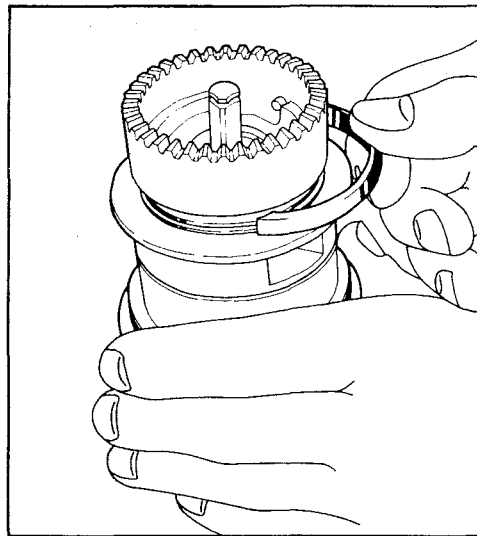

**FIGURE 1-22
REMOVING FACE GEAR
RETAINING RING**

- (8) Remove face gear from lower head assembly. Refer to Fig. 1-23.

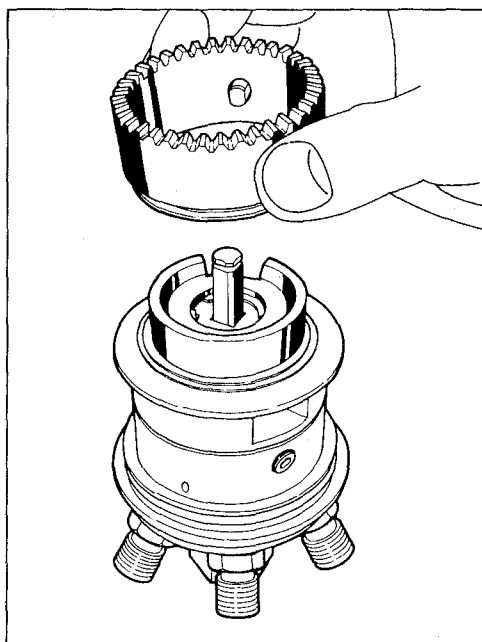

**FIGURE 1-23
REMOVING FACE GEAR**

- (9) Next, remove drive hub from lower head assembly.

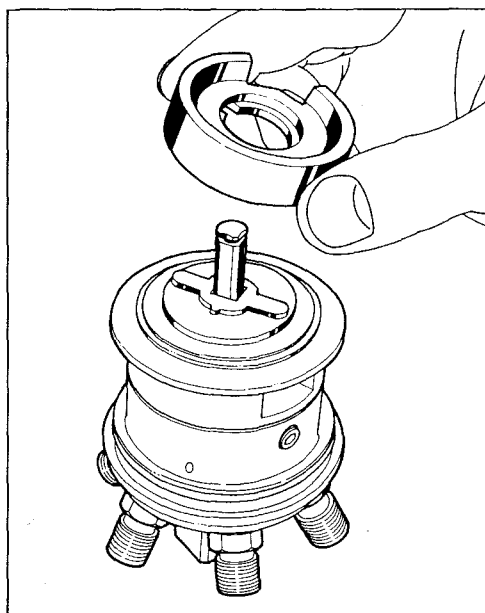

**FIGURE 1-24
REMOVING DRIVE HUB**

Note: Either a two piece or one piece face gear may be supplied per customer's specifications.

- (10) Pull the plunger out of the head and remove the plunger guide. (Refer to Fig. 1-25). Place the plunger on a clean cloth.

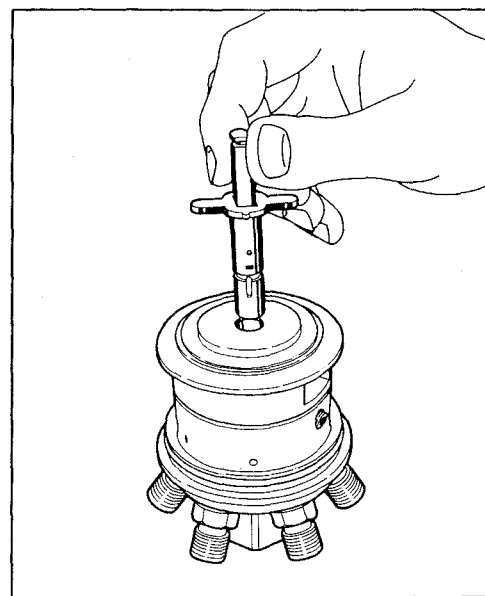

**FIGURE 1-25
REMOVING PLUNGER GUIDE
AND PLUNGER**

- (11) Remove the thrust washer from hydraulic head.

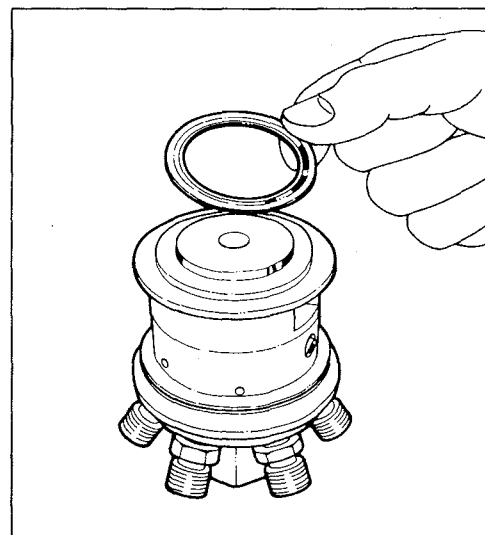

**FIGURE 1-26
REMOVING FACE GEAR THRUST
WASHER**

- (12) Slide the plunger sleeve out of the rectangular hole in head and place the sleeve on a clean cloth.

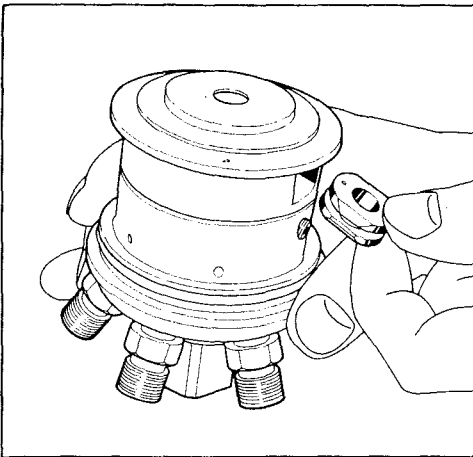

**FIGURE 1-27
REMOVING PLUNGER SLEEVE**

Important: The plunger, plunger sleeve and hydraulic head are mated parts and must always be kept together.

(13) Procure or fabricate a rectangular, brass bar 0.765" to 0.775" wide, 0.490" to 0.500" thick and about 6" long. Slide the brass bar through the rectangular hole in the head and clamp the bar in a vise with head assembly upright.

Important: Do Not Clamp Hydraulic Head Directly In Vise.

(14) Remove capnut, previously loosened.

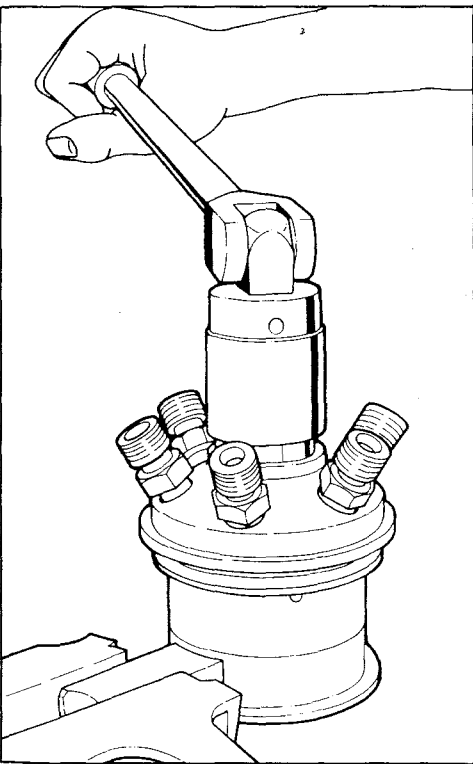

**FIGURE 1-28
REMOVING DELIVERY VALVE HOLDER
CAPNUT**

(15) Remove delivery valve holder previously loosened.

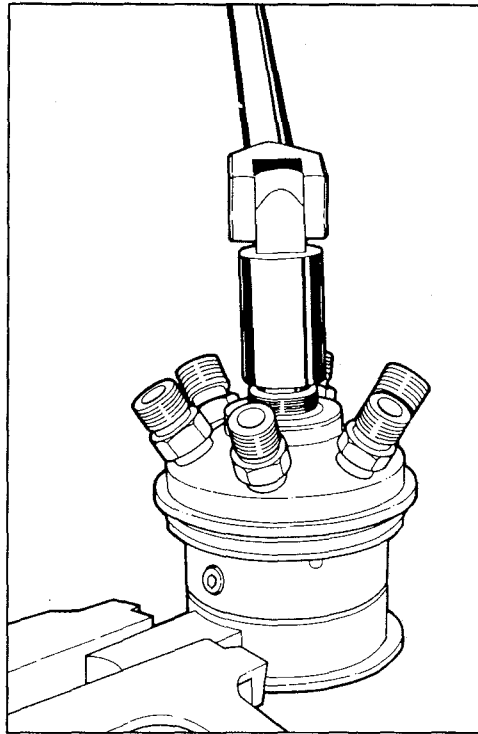

**FIGURE 1-29
REMOVING DELIVERY VALVE HOLDER**

(16) Remove steel gasket from delivery valve holder.



**FIGURE 1-30
REMOVING CAPNUT GASKET**

(17) Remove delivery valve spring, spring seat, delivery valve and valve body by inverting the head. Refer to Fig. 1-31.

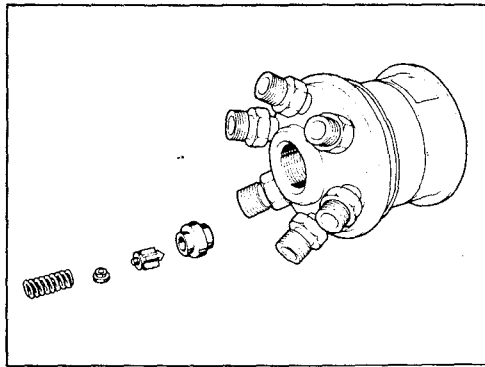

FIGURE 1-31
DELIVERY VALVE ASSEMBLY, SPRING SEAT AND SPRING REMOVED

Note: Early pumps may be equipped with a spacer which fits around the lower delivery valve body and may remain in head bore when valve assembly is removed. Remove spacer with tweezers.

- (18) Remove upper head "O" ring using an awl or scribe.

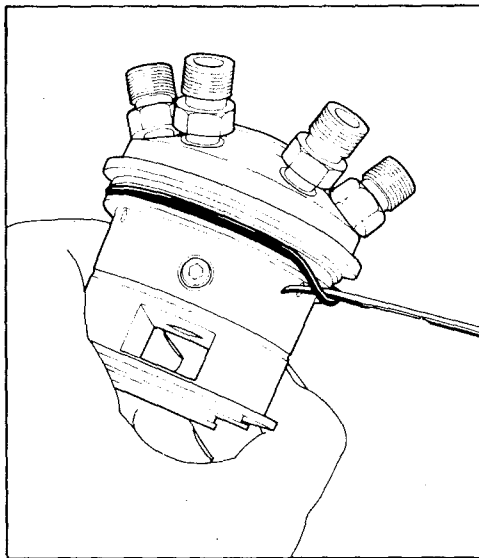

FIGURE 1-32
REMOVING UPPER HEAD "O" RING

Important: Do not loosen or remove the Allen set screw and sealing ball if the screw is in good condition. Remove only if loose or damaged.

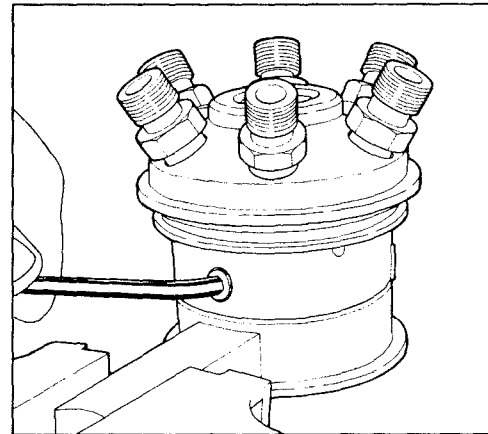

FIGURE 1-33
REMOVING SET SCREW

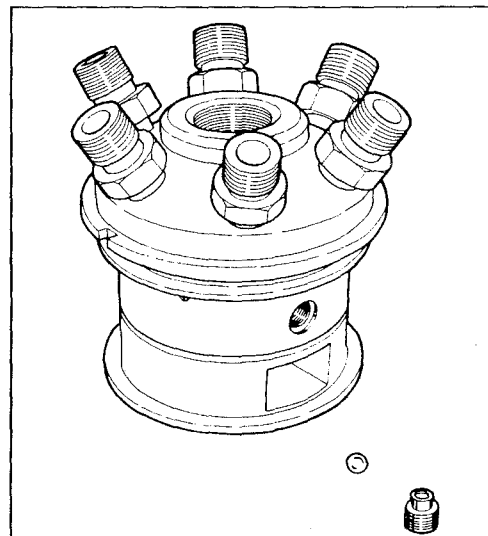

FIGURE 1-34
SET SCREW AND SEALING BALL REMOVED

- (19) Remove only those discharge fittings that are damaged and require replacement.

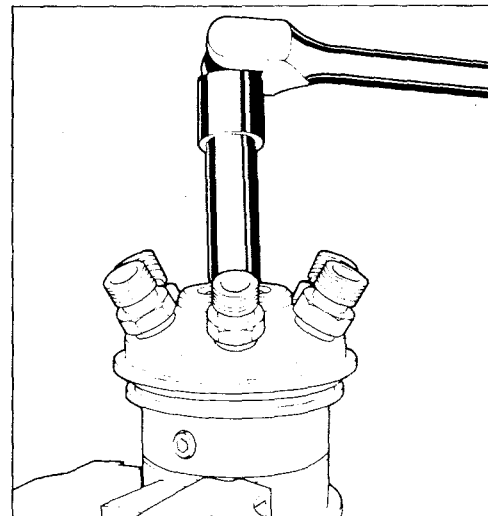

FIGURE 1-35
REMOVING DISCHARGE FITTINGS

(20) Wash all parts in Varsol or an equivalent cleaning agent. Note special cleaning instructions for the following components and areas:

- (a) **HYDRAULIC HEAD** — the head, plunger and plunger sleeve are mated parts and have an extremely fine surface finish. It is imperative that these three parts be washed separately in **clean** solvent to avoid contamination and possible contact with other metal parts.
- (b) **DELIVERY VALVE ASSEMBLY** — the valve and body are also mated parts and should be washed separately to avoid damage.
- (c) Remove all gasket remnants from gasket surfaces. A scraper can be used, but care must be taken to avoid scratches.
- (d) Blow dry, filtered compressed air through fuel ducts of head to make certain all ducts are clean and open.
- (e) Dry all parts thoroughly and place them on a clean cloth.

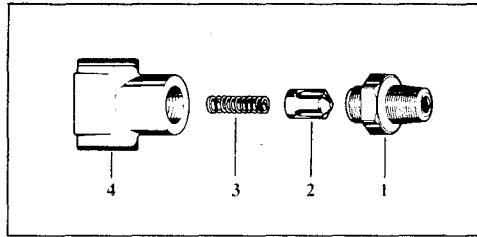

FIGURE 1-36
EXPLODED VIEW OF OVERFLOW VALVE

(4) If pump is equipped with overflow fitting (or check valve) and inlet fitting, they can be removed.

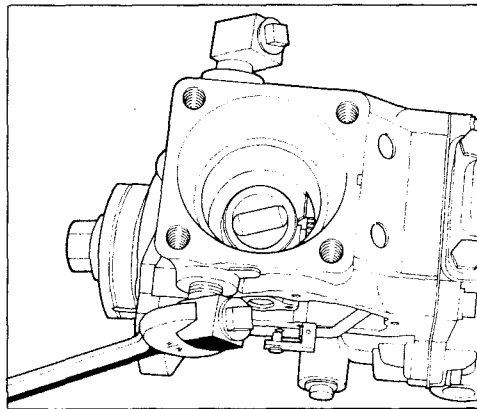

FIGURE 1-37
REMOVING FITTINGS

1. Removal and Disassembly of Overflow Valve (Removal of Inlet and Outlet Fittings)

- (1) Early pumps were equipped with an overflow valve as shown in Fig. 1-36. Remove by engaging open end wrench on flats of retaining screw (1).
- (2) **Carefully** clamp reinforced flats of housing (4) in a **SOFT-JAWED** vise. **Do Not Crush** housing by overtightening vise.
- (3) Remove retaining screw (1), valve (2) and spring (3) from housing (4).

Table 1

Note: Unless otherwise noted, all numbers in parentheses in this section, refer to illustration numbers in Figure 1-5.

PARTS	INSPECT FOR FOLLOWING CONDITION(S)	CORRECTIVE ACTION WHEN REQUIRED
1. HYDRAULIC HEAD		
1) Delivery Valve (6) Seat in Head	Scored, pitted, eroded or damaged.	Refinish smooth with Lapping tool, TSE 7986 (which includes lapping arbor #TSE 7986-1). Use lapping compound #TSE 77103.
2) Delivery Valve (6) Body Seat	Scored, pitted, eroded or damaged.	Replace Valve Assembly.

C. Component Inspection and Testing