

# B. Differential Pump Calibration

**Note:** Two revolutions of the pump camshaft are required to provide one injection for each pump discharge outlet and, therefore, the test stand stroke counter **MUST** be set for twice the number of strokes indicated in the pump calibration specifications.

- (1) Start lube oil supply pump and adjust pressure to 55 psi (380 KPa).
- (2) The excess fuel device or puff limiter excess fuel device should be checked to make certain the device is not sticking. With the operating lever in the low idle position (towards drive end), proceed as follows:
  - (a) Reduce lube oil pressure to zero psi. The stop plate must fully retract to its static position (toward the excess fuel device housing).
  - (b) Gradually increase lube oil pressure to 30 psi (210 KPa). The stop plate must move smoothly to its fully extended position.
  - (c) Repeat this procedure several times.
  - (d) If binding or sticking is evident, repair or replace excess fuel device.
- (3) If pump is equipped with an electric shut-off assembly (solenoid), connect a 12 or 24 volt D.C. power supply (required voltage is stamped on solenoid housing) between solenoid input terminal and a control unit cover screw.
- (4) Readjust lube oil pressure to 55 psi (380 KPa). With operating lever in low idle position, start test stand at slowest possible speed.
- (5) Move operating lever to full fuel position, operate pump at 1000 RPM and check for leaks.
- (6) Refer to calibration section of applicable pump parts list for calibrating specifications.
- (7) With operating lever in full fuel position, operate pump at full load (rated) speed and allow pump to warm up for a minimum of 10 minutes or until specified test oil temperature is obtained.
- (8) Remove top cover and back out droop screw. Back out low idle screw & high idle screw several turns each.
- (9) With operating lever in full load position, adjust lube oil pressure to 10 PSIG. Verify that stop plate fully retracts to excess fuel position and check starting fuel at specified RPM. (Set tach counter at 200 revolutions for 100 stroke delivery). If delivery is below the specified minimum, proceed as follows:
  - (a) Remove and re-install delivery valve to eliminate a possible cocked delivery valve condition.

- (b) Install a new delivery valve if erosion exists on delivery valve body.
- (c) Determine full load fuel delivery and reset to specification if significantly below requirement. Then, re-check starting fuel.
- (d) Check lift-to-port closing dimension and adjust if necessary. (Refer to Section VI A)
- (e) If starting fuel still does not meet requirement, replace hydraulic head.

**Note:** In order to check starting fuel without breaking the top cover seal when making a calibration check, proceed as follows:

- a. Lock operating lever in full fuel position (pump not running on test stand).
- b. Reduce lube oil pressure to 10 PSIG (69 K Pa).
- c. Shut off lube oil supply pump and wait 10 to 20 seconds for lube oil pressure to dissipate.
- d. Turn lube supply pump back on (with lube pressure regulated at 10 psi).
- e. Run pump at cranking speed and record starting fuel delivery.

- (10) Loosen cam nut and adjust torque cam to obtain the approximate cam nose to fulcrum lever angle (see fig. 7-2) specified. **DO NOT** attempt to move cam unless nut is loose. Tighten nut following cam adjustment.

**Note:** The cam angle specified is only a reference point and, therefore, is an approximate angle. The angle may require readjustment later on in order to obtain the required peak torque delivery.

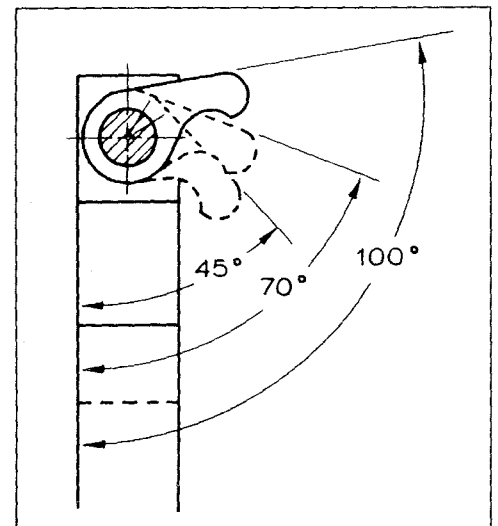

**FIGURE 7-2  
CAM NOSE ANGLE**

- (11) If pump is equipped with a puff limiter excess fuel device, the puff limiter piston **MUST** be clamped in the retracted position using TSE 79103.

**Note:** The puff limiter piston **MUST** also be retracted when making a calibration service check. This can be accomplished by applying 17 PSIG filtered, compressed air to the diaphragm cover inlet.

- (12) With operating lever in full fuel position and pump operating at full load (rated) speed, take 3 or 4 sample draws to make certain that system has been purged of air and that fuel delivery has stabilized.
- (13) Check fuel supply pump pressure which must be 40 psi (276 KPa) minimum at pump inlet at full load (rated) speed.
- (14) With operating lever in full fuel position, loosen stop plate lock nut and turn stop plate adjusting screw clockwise (to decrease fuel) or counterclockwise (to increase fuel) to obtain specified full load (rated) delivery. Tighten nut before taking each fuel draw.

**Note:** At rated speed, cam nose **must** contact stop plate. Droop screw must **not** contact stop plate.

**Important:** Fuel delivery variations between pump outlets will be noted when checking fuel deliveries. Since these variations cannot be eliminated, it is necessary to add the deliveries of all 6 outlets together and then divide the total delivery by 6 to determine the average delivery.

The maximum permissible variation between any 2 outlets at **full load** speed is as follows:

Full Load Delivery (cc/500 strokes)	Maximum Variation (cc/500 strokes)
25-39 cc	3.0 cc
40-54 cc	4.0 cc
55-65 cc	4.5 cc

- (15) With operating lever in full fuel position, reduce pump RPM to peak torque speed and take a draw. Calculate difference between peak torque delivery figure and the full load delivery figure. The result is the differential which must be within the "Peak Torque-Differential" limits indicated in the calibration specifications. If adjustment is necessary, loosen cam nut and make small changes in cam angle as follows:

- (a) Increase cam angle to increase peak torque delivery to obtain required differential.
- (b) Decrease cam angle to decrease peak torque delivery to obtain required differential.

Make certain that the cam nut is tightened following each cam angle adjustment.

**Note:** Each time the cam angle is readjusted, recheck/readjust full load delivery since it may change. Readjust cam angle and recheck/readjust full load delivery as many times as is necessary to obtain required differential and proper delivery at rated speed. Record final fuel deliveries at rated and peak torque RPM.

- (16) Increase pump speed 200-300 RPM above full load speed and decelerate to specified "Cam Departure — RPM". Adjust high idle screw so that cam nose just leaves stop plate.

- (17) Increase pump speed to "High Speed Shut-off RPM". Fuel delivery **MUST NOT** exceed 2cc/500 strokes. If adjustment is necessary, readjust cam departure speed downward slightly (but not more than 15 RPM below specified speed). If fuel delivery is still higher than specified, verify that governor components are correct per applicable pump parts list.

- (18) With operating lever in full fuel position, decelerate to "Droop Screw-RPM" and take a draw. Calculate difference between droop screw delivery figure and peak torque delivery figure. The result is the differential which must be within the "Droop Screw-Differential" limits noted in the calibration specifications. If adjustment is necessary, loosen droop screw nut and turn droop screw as follows:

- (a) Clockwise to decrease delivery to obtain required differential.
- (b) Counterclockwise to increase delivery to obtain required differential.

Make certain that droop screw nut is tightened following the adjustment.

- (19) Check to make certain that droop screw does not contact stop plate at peak torque speed.

- (20) Place operating lever in low idle position and operate pump at low idle speed. Adjust low idle screw to obtain specified low idle delivery. Operating lever should be held **lightly** in low idle position by hand. **DO NOT** mechanically lock lever in low idle position.

**Note:** Some pumps do not include a low idle screw but instead are equipped with a low idle screw plug and gasket. (Actual low idle setting is made on the vehicle).

For these pumps, verification of low idle fuel delivery can be obtained at specified RPM by holding operating lever at appropriate position (which will yield listed delivery) and record the fuel delivery.

- (21) If pump has a puff limiter excess fuel device, remove clamp from puff limiter piston.
- (22) Clamp excess fuel device in excess fuel (inward) position.
- (23) Recheck starting fuel with operating lever in full load position (see Step 9).
- (24) If pump is equipped with a puff limiter excess fuel device, secure puff limiter (top) cover to governor housing and check fuel delivery at full load (rated) speed with operating lever in full fuel position as follows:
  - (a) With 17 PSIG air pressure (filtered, compressed air) at top cover inlet, delivery must be equal to full load delivery  $\pm$  1cc/500 strokes.
  - (b) With 0 air pressure at top cover inlet, delivery must be within the "Puff Limiter Delivery Check" specifications.

**Note:** If fuel deliveries obtained in steps 24 (a & b) above do not meet specifications, refer to Governor Section II.C. 5.3 which includes procedures for checking and setting "A Dimension Travel" and puff limiter "Spring Preload". If "A Dimension" and/or "Spring Preload" of the puff limiter excess fuel device are adjusted, recheck calibration and reset if necessary.

- (25) Check shut off mechanism to make certain that fuel delivery stops **completely** at **both** full load (rated) and low idle speeds. Operating lever should be in full load position at rated speed and in low idle position at low idle speed. Reference applicable shut-off device as follows:

(a) **Pumps equipped with electric (solenoid) shut-off assembly**

Disconnect one power supply lead from pump (or turn off power); and check for complete shutoff. Activate solenoid several times to make certain that solenoid plunger is not sticking. Fuel delivery must stop immediately when power is shut off and must start immediately when power is turned on (at rated and low idle speeds).

If solenoid does not function properly or a binding condition exists, repair or replace the solenoid. (Refer to Shutoff Device Section VB).

(b) **Pumps equipped with Bowden wire shutoff assembly**

Pull Bowden wire shutoff rod all the way out and check for complete fuel shutoff at rated and low idle speeds. Release shutoff rod. It must retract fully into cover.

(c) **Pumps equipped with operating lever only (low idle screw capsule)**

Force operating lever beyond low idle stop until piston in low idle screw capsule assembly bottoms. Check for complete fuel shutoff at rated and low idle speeds. Fuel delivery should commence when operating lever is released.

- (26) Bend the center tab of stop plate tab washer over top of stop plate. Tighten stop plate nut to value listed in Torque chart, Section XI. Do not over-tighten since it may result in damage to the adjusting screw and/or a sticking/binding excess fuel device.
- (27) Bend one of the remaining two tabs of tab washer against one flat of the stop plate nut to lock the nut in place.
- (28) Check to make certain that the following lock nuts are tightened to proper value per Torque Chart, Section XI:
  - (a) Cam nut
  - (b) Droop screw nut
  - (c) High idle screw nut and capnut
  - (d) Low idle screw
- (29) Install governor top cover gasket and cover to governor housing. Gasket should be installed dry — no sealer is required with this type of gasket.
- (30) Install the four top cover screws with gaskets so that screw with lockwire hole is in screw hole closest to control unit cover. Tighten the screws per value listed in Torque chart, Section XI.
- (31) Operate pump at full load speed and check for lube oil leaks at top cover.