

**ENGINE  
GOVERNING SYSTEMS**



MP675, MP676, MP677, MP678,  
MP679A, MP6710A

Supersedes Issue  
Dated December 1984

## Magnetic Speed Sensors

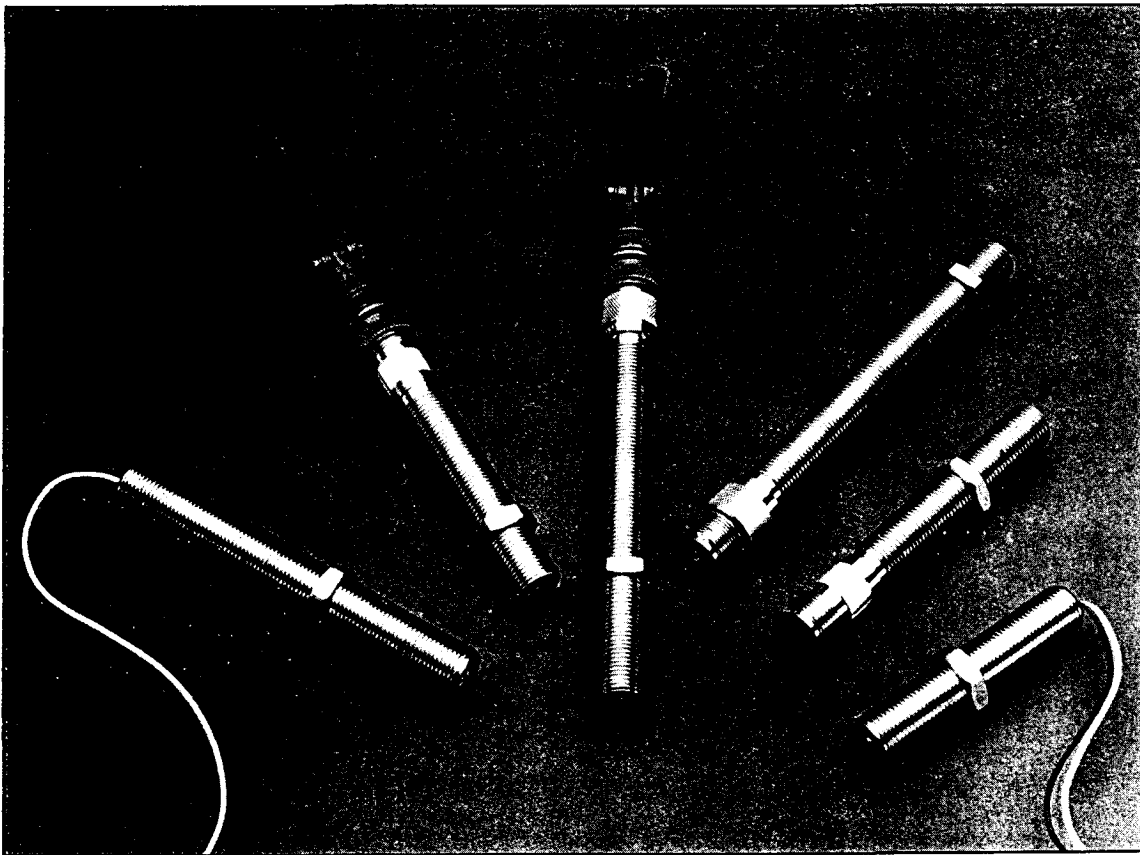

# ENGINE GOVERNING SYSTEMS



## Magnetic Speed Sensors

Supersedes Issue  
Dated December 1984

### INTRODUCTION

The magnetic speed sensor is a variable reluctance type sensor. It contains a coil and permanent magnet, and is "passive" in the sense that it requires no power source. It responds to the teeth and gaps of an engine flywheel or other ferrous projections passing by its tip. The pulses induced

onto the coil are sent to a speed control unit or speed switch. The frequency of these pulses is directly proportional to engine RPM.

See Table A for Speed Sensor model variations.

### INSTALLATION

The speed sensor is typically mounted in the flywheel bell housing. The threaded hole should be relatively perpendicular to the flywheel centerline. A spot face should be provided for a flat surface to anchor the locknut securely. With the engine off, screw in the speed sensor until the tip comes in contact with the top of a gear tooth. Then back it off between  $\frac{1}{2}$  to  $\frac{3}{4}$  of a turn. That will provide a gap of approximately 0.030 inch.

The two wire leads from the speed sensor are connected to the speed control unit. For short lengths (under 3 meters), wire leads should be twisted or shielded. For lengths longer than 3 meters use shielded wire. Do not ground the shield or either of the speed sensor leads at the speed sensor end. One of the two speed sensor input terminals on the speed control unit is internally connected to ground. Connect both the shield and one of the two sensor leads to that terminal. See Table B.

### TROUBLESHOOTING

Signal strength across the output leads is a minimum of 1.0 VAC (rms). Anything less indicates a gap that is too large,

excessive load across the output leads, or a defective sensor.

### SPECIFICATIONS

—Type .....	Passive, permanent magnet, variable reluctance
—Dimensions (Unshielded) .....	See Figure 1
—Dimensions (Shielded) .....	See Figure 2 and Figure 3
—Thread Size .....	5/8 - 18 UNF-2A
—Tap Drill Size .....	37/64"
—Proximity to Gear Teeth .....	0.75mm (0.030 in.)
—Temperature Range .....	-55° to + 105°C (-65° to + 225°F)
—Output .....	1.0 to 30 volts RMS
—Resistance .....	40 to 85 ohms
—Inductance .....	25 mH

#### OPTIONAL:

—Mating Connector for MP677, MP678 .....	MS3106A-10SL-4S order EC1267-1
—Cable Clamp and bushing for MP677, MP678 .....	M85049/41-4A, MS3420-4 order AD673

# ENGINE GOVERNING SYSTEMS



Magnetic Speed Sensors

Supersedes Issue  
Dated December 1984

Model	Length	Termination
MP675	3"	1 foot wire
MP676	5"	1 foot wire
MP677	3"	connector w/o mate or clamp
MP678	5"	connector w/o mate or clamp
MP679A	3"	connector with mate (EC1267-1) and clamp (AD673)
MP6710A	5"	connector with mate (EC1267-1) and clamp (AD673)

**Table A**  
**Magnetic Speed Sensors Variations**

# ENGINE GOVERNING SYSTEMS

# AMBAC<sup>®</sup>

INTERNATIONAL

Magnetic Speed Sensors

Supersedes Issue  
Dated December 1984

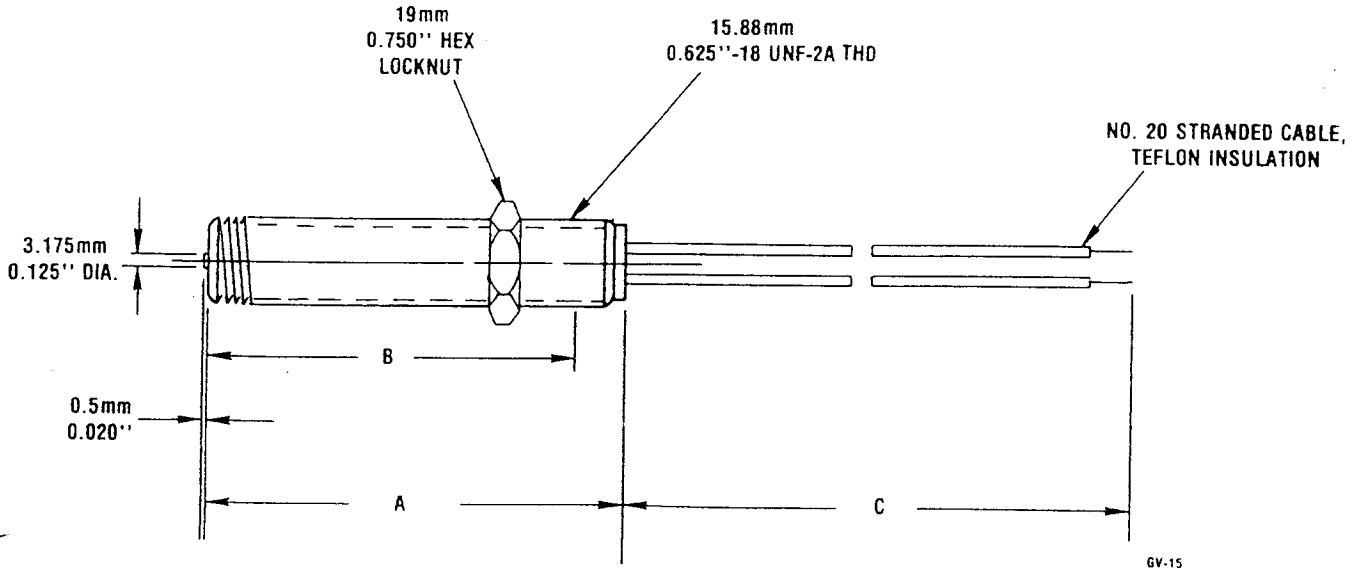

CAT. NO.	DIMENSION A	DIMENSION B MAX. USABLE THREAD LENGTH	DIMENSION C WIRE LEAD LENGTH
MP675	76mm 3 inches	67mm 2-5/8 inches	305mm 12 inches
MP676	127mm 5 inches	118mm 4-5/8 inches	305mm 12 inches

Figure 1.  
MP675 and MP676

# ENGINE GOVERNING SYSTEMS

# AMBAC<sup>®</sup>

INTERNATIONAL

## Magnetic Speed Sensors

Supersedes Issue  
Dated December 1984

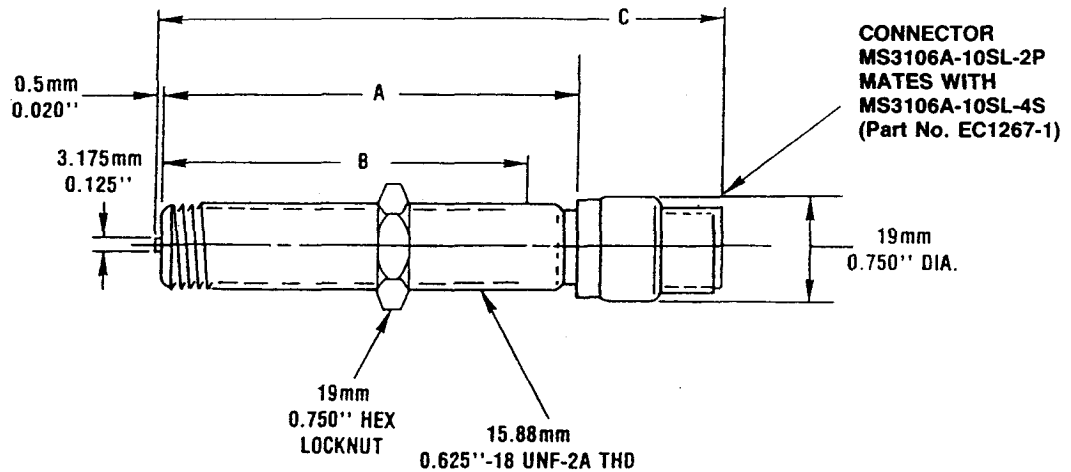

CAT. NO.	DIMENSION A	DIMENSION B MAX. USABLE THD LENGTH	DIMENSION C PICKUP LENGTH
MP677	76mm 3 inches	67mm 2-5/8 inches	108mm 4-1/4 inches
MP678	127mm 5 inches	118mm 4-5/8 inches	156mm 6-1/8 inches

Magnetic speed sensors are supplied without the mating connector, cable clamp and bushing.  
See "Specifications" on page 1 for details.

Figure 2.  
MP677 and MP678

# ENGINE GOVERNING SYSTEMS

# AMBAC<sup>®</sup>

INTERNATIONAL

## Magnetic Speed Sensors

Supersedes Issue  
Dated December 1984

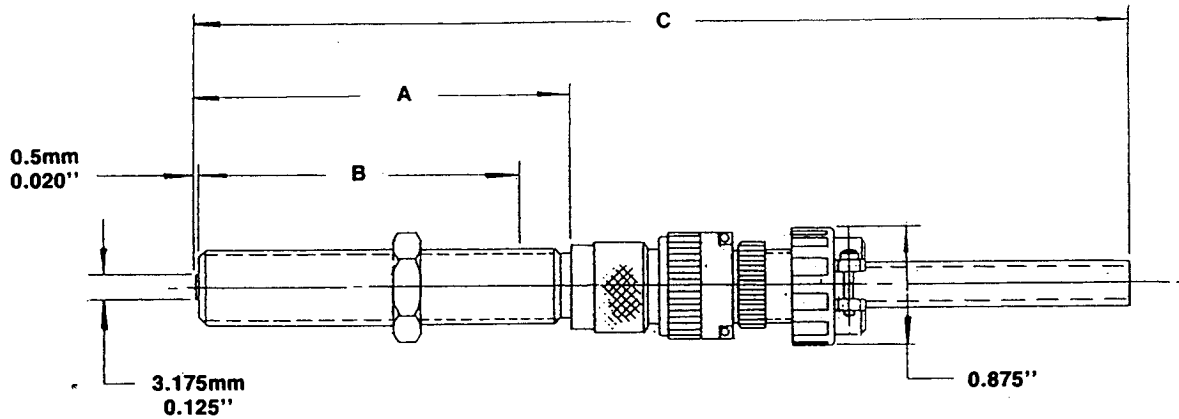

CAT. NO.	DIMENSION A	DIMENSION B MAX. USABLE THD LENGTH	DIMENSION C PICKUP LENGTH (INCL. BUSHING)
MP679A	76mm 3 inches	67mm 2-5/8 inches	197mm 7-3/4 inches
MP6710A	127mm 5 inches	118mm 4-5/8 inches	248mm 9-3/4 inches

Magnetic speed sensors are supplied with connector MS3106A-10SL-4S, cable clamp M85049/41-4A and bushing MS3420-4.

**Figure 3.**  
**MP679A and MP6710A**

# ENGINE GOVERNING SYSTEMS



Magnetic Speed Sensors

Supersedes Issue  
Dated December 1984

SPEED CONTROL UNIT	MAGNETIC SPEED SENSOR CONNECTIONS	
	SIGNAL	RETURN LINE and SHIELD
CU 671C & 673C Series ECD 67-5111, 5221 ECD 67-2110, 2112 ECJ 1000	S C 3 19	T D 4 20
<b>SPEED SWITCH</b>		
SWA 676B	1	2

**Table B**  
**Wiring Connections**