



Conforms to EC Directive on  
Electromagnetic Compatibility



Quality System Certification



## Model SY6000 Synchronizer

### Features

- Compatible with AMBAC, GAC, Cummins EFC, and Barber Colman Speed Controllers
- Speed capture range typically  $\pm 4\%$
- Controls 12 and 24 volt systems
- Typically captures in less than 3 seconds
- Wide voltage range on inputs - Line to line or Line to neutral sensing
- Phase capture range typically  $\pm 25^\circ$
- Phase error  $< 2^\circ$

The SY6000 operates in conjunction with an electric governor system to allow the safe connection of a slave genset to either the mains bus or a master genset.

The synchronizer senses the frequency and phase of both the mains/master and the (slave) and supplies a speed trim signal to the slave genset's speed control unit to adjust its engine speed until the main/master and slave frequency and phase are matched. When this matching occurs, relay contacts in the synchronizer close to initiate load contactor actuation, while disconnecting the synchronizer itself.

The synchronizer is fast-acting, with typical synchronization in both frequency and phase obtained in less than 3 seconds when the genset is within the capture window.

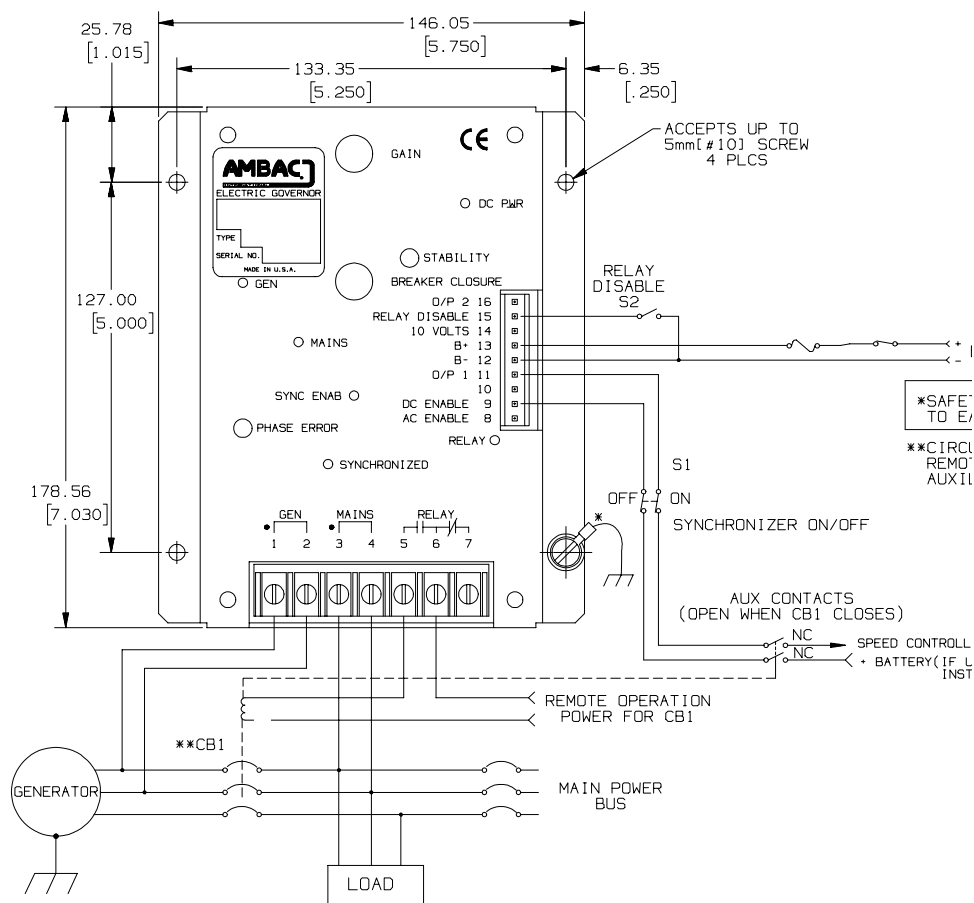

**Caution Note:**  
Connections illustrated  
are suggested only. All  
components and wiring  
must be selected and  
installed in conformance  
with local regulations.

Figure 1. Outline Dimensions and Typical Connections

## Description

The SY6000 operates by sensing a master input signal from the main power bus and comparing it with the frequency and phase of the slave signal from a generator which is to be synchronized to the bus. The error signal from the comparator circuit in the synchronizer is a measure of the speed and phase difference between the mains and the generator. The dynamic control and output circuits of the synchronizer send a trim signal to the speed control unit to adjust the engine speed and thus reduce the frequency and phase error. Control adjustments for PHASE ERROR (between the Genset and the Main), GAIN, Stability and Breaker Closure (Angle), located through the cover, are used to optimize the performance of the unit.

Inputs connect to the Generator (GEN) and Mains power lines and to BATTERY power. Inputs also connect to either an AC or DC ENABLE signal which enables the speed trim output to the Speed Control Unit. Another input allows disabling the internal SPDT relay which controls an external contactor for paralleling with the Main. The relay contacts are available at the external terminals.

Two speed trim outputs are provided. One, called O/P 1, interfaces with AMBAC and other similar Speed Control Units. The second, O/P 2, provides the opposite phase and a different reference voltage and interfaces with Cummins EFC and Barber Colman units. The internal 10VDC supply is also made available at the terminals.

LED Indicators are provided to allow easy setup and troubleshooting. These indicators show the presence of the Generator (GEN) and MAINS power, proper DC power within the Synchronizer, presence of a SYNC ENABLE input, when the genset is SYNCHRONIZED to the Mains, and when the internal relay is actuated.

## Performance Specifications

Outputs		
Engine Speed Trim Signal Phase - O/P		Voltage drops to increase speed
- O/P 2		Voltage increases to increase speed
Inputs		
Generator Frequency		30 - 500 Hz
Speed Capture Range	typ	±4% (based on 3250 Hz speed sensor signal) <sup>1</sup>
Phase Error		Factory set to less than 2 degrees
Breaker Closure Angle (Window)		0° ± 30° continuously adjustable <sup>2</sup>
Signal Voltage Range - Line-to-Line	min	140 - 500 Vrms
- Line-to-Neutral	min	80-280 Vrms
Supply Voltage (Battery)		12 - 30 Vdc
Supply Current	max	100 mA
Output Relay Contact Rating	max	10 amp, 30 Vdc
Environmental		
Temperature range		-40°C<T<+80°C (-40°F<T<+176°F)
Humidity		Up to 100% <sup>3</sup>
Vibration		5g (20-2000Hz)
Enclosure		Fungus proof and corrosion resistant

### Notes

- 1 Mag sensor frequency in Hz = (engine RPM) x (number of teeth on flywheel) / 60
- 2 Factory set to ±6°
- 3 Printed circuit boards are fully conformally coated

### Ordering Information

SY6000

Model Number  
Standard Unit

Consult Factory for Other Options

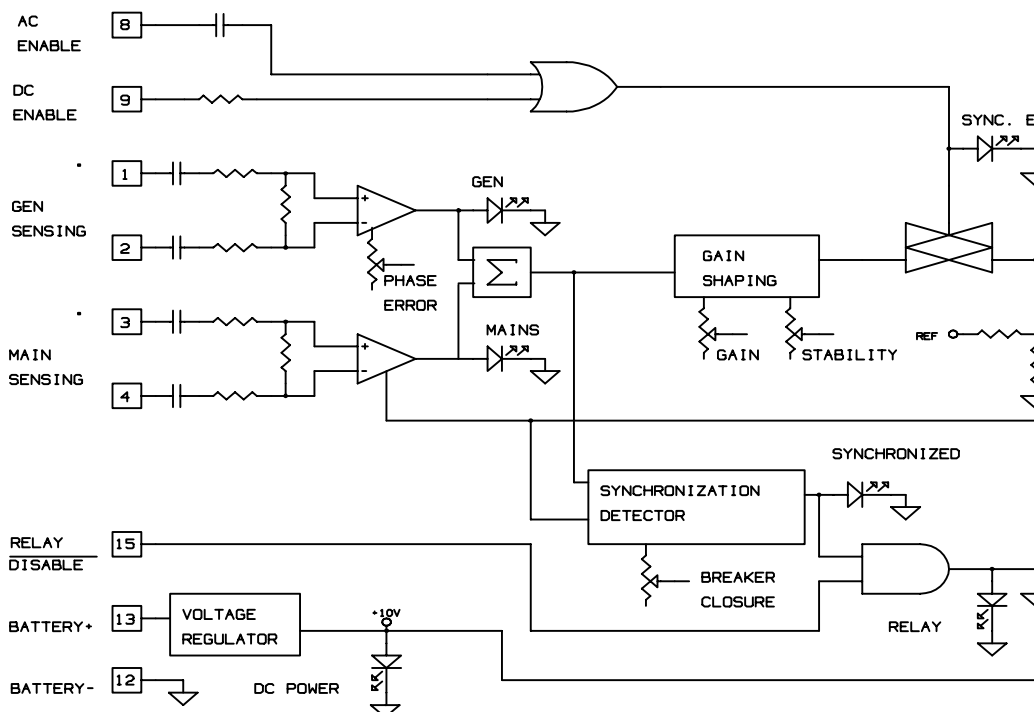

Figure 2. Simplified Schematic



# SY6000 SYNCHRONIZER INSTALLATION INSTRUCTIONS

## INTRODUCTION

When paralleling a synchronous generator to a main bus consisting of other generators or the utility, both the phase and voltage levels of each power system must be matched **BEFORE** the actual connection is made. The SY6000 is an accessory module which adjusts a genset's electronic governing system speed

control unit to obtain an identical phase relationship between the oncoming genset and the main bus. The typical time for synchronization is usually less than 3 seconds when the genset is at rated speed with optimum governor performance settings.

## DESCRIPTION

The synchronizer monitors the phase and frequency of its generator and the main bus (See Figure 1). The two AC signals are electrically isolated from each other and from the governor speed control units. The phase of the two AC signals is compared and a correction signal for the generator's speed control is generated. This correction signal adjusts the electric governor speed setting and is applied by the synchronizer until the electrical phase error between the generator and the main bus is eliminated. This synchronization process commences only with the presence of both GEN and MAINS AC signals and an ENABLE signal at Terminals 8 or 9. Any phase error that remains after synchronization may be trimmed out by using the internal **PHASE ERROR** adjustment. When the ENABLE signal at Terminals 8 or 9 is removed, the synchronizer will assume a neutral output.

A wide range of AC input voltages and wave shapes can be accepted by the synchronizer. If the generator output voltage exceeds the specified input limits of the SY6000, isolation transformers with a suitable step-down ratio will be required. Isolation between input signals allows each generator to be isolated from each other until the actual paralleling occurs.

A measurement of the phase relationship between the two AC inputs is continuously available (when an ENABLE signal is also present) as an analog voltage at Terminal 11. A level of approximately 5.0 V indicates an in-phase condition. The synchronizer's dynamic control circuits include graduated **GAIN** and **STABILITY** adjustments. These controls are used to obtain optimum synchronization times and

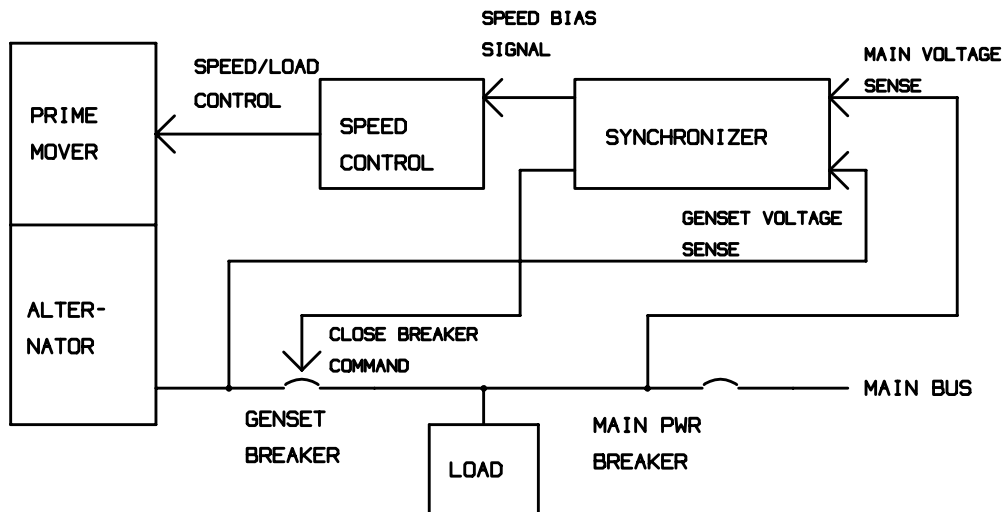

Figure 1. System Block Diagram

## DESCRIPTION Cont.

stable performance. The **GAIN** adjusts the sensitivity of the synchronizer output to the governor. A clockwise adjustment increases the sensitivity of the system. The **STABILITY** adjusts the time rate of the response of the synchronizer output. Both controls operate independently, are easily optimized, and are similar in function to the gain and stability adjustments on AMBAC Speed Control Units.

An internal synchronization detection circuit has its own variable phase angle window for controlling the breaker closure. The phase angle window may be adjusted between 0 and 25 degrees. CCW rotation of the graduated **BREAKER CLOSURE** angle adjustment reduces the window to near 0 degrees, inhibiting breaker closure. The phase angle between the two AC signals must stay within the phase angle window range for at least 1/2 second for synchronization to occur. If during this time the phase angle momentarily exceeds the breaker closure setting, the time period of 1/2 second must be repeated. System stability is very important during this critical time period.

Once synchronization is complete and the units are paralleled, the synchronizer should be reset to its neutral output and disabled position. The wiring diagram in the SY6000 Data Sheet shows a switching method that resets the unit by disconnecting the

synchronizer output from the speed control unit and opening the ENABLE line at Terminals 8 or 9. The synchronizer now assumes a neutral position with Terminal 11 holding a constant output voltage of 5.0 Volts.

Synchronizer operation may be checked/tested without activating the breaker closure relay by connecting a jumper or a switch between Terminals 15 and 12. With this jumper in place, the synchronizer functions normally except the breaker closure relay will not close. (The green LED indicator that signifies when the generator is **SYNCHRONIZED** will operate during this test.) Disconnection of the MAINS input signal (Terminals 3 and 4) also inhibits relay closure by preventing synchronization.

### Dead Bus Operation

If the MAINS input is missing, the synchronizer will not attempt to synchronize the system and the green **SYNCHRONIZED LED** will not illuminate. A different switching arrangement system may be used to close this first oncoming generator onto the dead bus which will then provide a reference to which other on-coming generators may synchronize.

## COMPATIBILITY

This unit is directly compatible with all AMBAC speed controls, interface modules, as well as electronic governor systems from various manufacturers.

**Note 1:** The polarity of the output voltage at Terminal 11 is such that a voltage increase is intended to decrease engine speed. Use the reverse polarity output at Terminal 16 if applying the SY6000 to certain other manufacturer's speed controls (i.e., Cummins EFC, Barber Colman).

## INSTALLATION

The synchronizer was designed with the same rugged construction as all AMBAC electronic products and may be mounted in a control cabinet with other equipment. Care should be taken to limit exposure of the unit to extreme temperatures. If water or condensation may come in contact with the synchronizer, mount it vertically to prevent accumulation inside the unit.

Connect according to the wiring diagram on the Model SY6000 Synchronizer data sheet supplied with the unit. For specific connections to the various AMBAC Speed Controllers or to Cummins and Barber Colman Speed Controllers, see Figures 2 and 3 in this document. Terminals 1 and 3, and Terminals 2 and 4 connect to the same phase lines of the respective sources. For line-to-neutral sensing, Terminals 2 and 4, are connected to the respective neutrals. Connecting cables carry low currents and large gauge wire is not required (AWG 20 wire is recommended). The connection between the speed control unit and synchronizer Terminals 11 and 16

### CAUTION

**HIGH VOLTAGE AC May be Present  
AT TERMINALS 1 - 7**

**De-energize and Check Voltages**

## INSTALLATION Cont...

### CAUTION

Do not operate Synchronizer without a good connection between terminal 12 and battery negative. In the absence of this connection, dangerous voltages can exist at the low voltage terminals 8 through 16.

### NOTE

The phasing of the mains and the generator signals is such that when synchronized, Terminals 1 and 3 are in phase. (See phasing dots on case.)

### CAUTION

The installer is responsible to insure that the installation is in conformance with all applicable local codes and regulations. Consistent with these requirements, a solid electrical connection should be provided between the metal cases of the Synchronizer and “earth ground” to prevent shock hazard to service personnel. A good ground should also minimize the effects of electrical noise on the speed control system.

One of the mounting screw locations on the Synchronizer is clear of paint (bare metal). A 20 AWG or larger grounding wire with a ring tongue terminal should be solidly fastened to the cast at this location by the mounting screw and the other end of the wire should be solidly connected to a good “earth ground”. Ensure that the metal is clean and free of corrosion, if necessary, and apply a coating of grease or lacquer to protect the bond.

are sensitive and must be shielded over their entire length. The shields should be connected at one end only, at the case, or at Terminal 12.

Since the SY6000 is a CE (Community Europe) conforming unit, certain installation requirements must be met to maintain this EMC immunity. The unit

must be securely mounted to a metal ground plane, shielded cables must be used where shown in the wiring diagram, and a ground strap must be connected from Terminal 12 to the case as shown in the wiring diagram. When installed according to these procedures, the synchronizer will have excellent resistance to external fields.

## ADJUSTMENTS

The governing system must be in good working order, stable, and adjusted correctly for the synchronizer to properly operate in the system. Accurate phase control can only be accomplished with a quality governing system.

- A. When the synchronizer is connected as per the wiring diagram, close switch S1, RELAY DISABLE (or add a jumper between Terminals 15 and 12) or disconnect the relay wires at Terminals 5, 6 and 7. This allows the generator to be synchronized to the mains without enabling paralleling.
- B. With the Genset running at the synchronous speed, see that the **DC PWR** indicator LED is illuminated. This verifies the internal +10 VDC power is present in the SY6000. See that both the **GEN** and **MAINS** indicator LEDs are illumi-

nated. This verifies AC power is present at these inputs. Check to confirm that the genset's governed frequency is within 0.1 Hz of the mains (or other genset as applicable).

- C. Close the connections between the synchronizer and the governor (Switch S1, SYNCHRONIZER ON). The **SYNC ENAB** indicator LED should be illuminated and the SY6000 will immediately attempt to synchronize its genset to the MAIN POWER BUS. **SYNCHRONIZED** indicator LED will be on when synchronized.
- D. The synchronizer is factory set to near optimum settings and large adjustments at installation are not usually required. Adjust the **GAIN** as far CW as possible without causing instability in the system. Set the **GAIN** one division CCW from the point where instability occurs.

- E. Unsynchronize the system by switching S1, SYNCHRONIZER OFF, disconnecting Terminals 8 and 11, or momentarily moving the engine throttle. Place S1, SYNCHRONIZER ON and observe the speed and stability of the synchronization with a synchroscope or phasemeter. Readjust the **GAIN** if necessary.
- F. Once the Gain is optimized, adjust the **STABILITY** in the same manner for a fast and smooth synchronization. A more CCW setting will result in a slower (more damped) but smoother response. Adjust for the desired performance.
- G. The **PHASE ERROR** adjustment can now be used to set the synchronizer for exact zero phase error. Verify this on a synchroscope, as a measurement of near zero AC Volts, or a null in AC voltage between Terminals 1 and 3 when the main bus and generator voltages are equal.
- H. Set the breaker closure angle by first turning the **BREAKER CLOSURE** fully CCW (zero degree phase angle window). The **SYNCHRONIZED** indicator LED will turn off. Turn the control CW

until the **SYNCHRONIZED** indicator LED turns on again, and continue CW one additional division. Approximate phase angle window values from the following table may also be used for setting the breaker closure angle.

**BREAKER CLOSURE ANGLE  
ADJUSTMENT**

Adjustment Setting	Breaker Closure Angle
0	0°
30	6°
50	12°
70	18°
100	25°

- I. Remove the jumper between Terminals 15 and 12 and/or reconnect the relay contact connections at Terminals 5, 6 and 7. Synchronizing and paralleling of the system may now be accomplished.
- J. For a final check, start the engine and synchronize the system to insure that all adjustments are optimal. If certain characteristics are unsatisfactory, consult the troubleshooting guide.

**TROUBLESHOOTING**

If the system fails to operate or synchronize properly, make the following measurements. (+) (-) refers to meter polarity.

**TERMINALS MEASUREMENT**

- 1. Measure the battery voltage between Terminals 13(+) and 12(-). It should be 12 or 24 VDC nominal.
- 2. Note the Red **DC PWR** indicator. It should be on. Measure the internal 10 V DC supply between Terminals 14(+) and 12(-). It should be 9.6 - 10.4 VDC.
- 3. Note the Red **GEN** indicator. It should be on. Measure the AC voltage between Terminals 1 and 2. It should be 80 - 500 VAC.
- 4. Note the Red **MAINS** indicator. It should be on. Measure the AC voltage between Terminals 3 and 4. It must be the same as in Step 3.
- 5. Note the Red **SYNC ENAB** indicator. It should be on if either the AC or DC ENABLE signal is present at Terminal 8 or 9. Check
- 6. Check the DC voltage between Terminals 10(+) and 12(-). This should be 10 V DC when MAINS voltage is present and of sufficient amplitude. If not, the unit may synchronize, but the relay will not close.
- 7. Measure the synchronizer's output analog voltage between Terminals 11(+) and 12(-). If the GEN frequency is lower than the MAINS, this voltage should be lower and vice-versa. Adjust the governor speed until 5.0 V DC is measured between Terminals 11(+) and 12(-).
- 8. If the green **SYNCHRONIZED** LED does not light, the **BREAKER CLOSURE** angle may be set too narrow. Adjust the **BREAKER CLOSURE** angle control CW until the green LED lights.

9. If the green **SYNCHRONIZED** LED lights continuously but the internal breaker closure relay fails to close, check for the (relay 1. inhibited) jumper or connection between Terminals 15 and 12.
10. If the Red **RELAY** indicator is on but the breaker does not close to parallel the units, check to make sure all external connections are made correctly. If this does not solve the problem, the synchronizer is defective.

### FAILURE TO SYNCHRONIZE OR SLOW SYNCHRONIZATION

1. This problem is usually caused by the governor performance not being tightly controlled. The governor performance must be excellent to obtain fast, consistent synchronization. Controlling the phase of a generator is a more demanding operation than basic speed control. Review and optimize the governor system before attempting to service the synchronizer. Other issues may lie within the engine and how well it is operating.
2. Severe harmonic distortion of the AC wave forms from power converters can disturb the synchronizer. If the wave form has more than 10% distortion, or other wave form issues are suspected, contact AMBAC for an external AC filter recommendation.

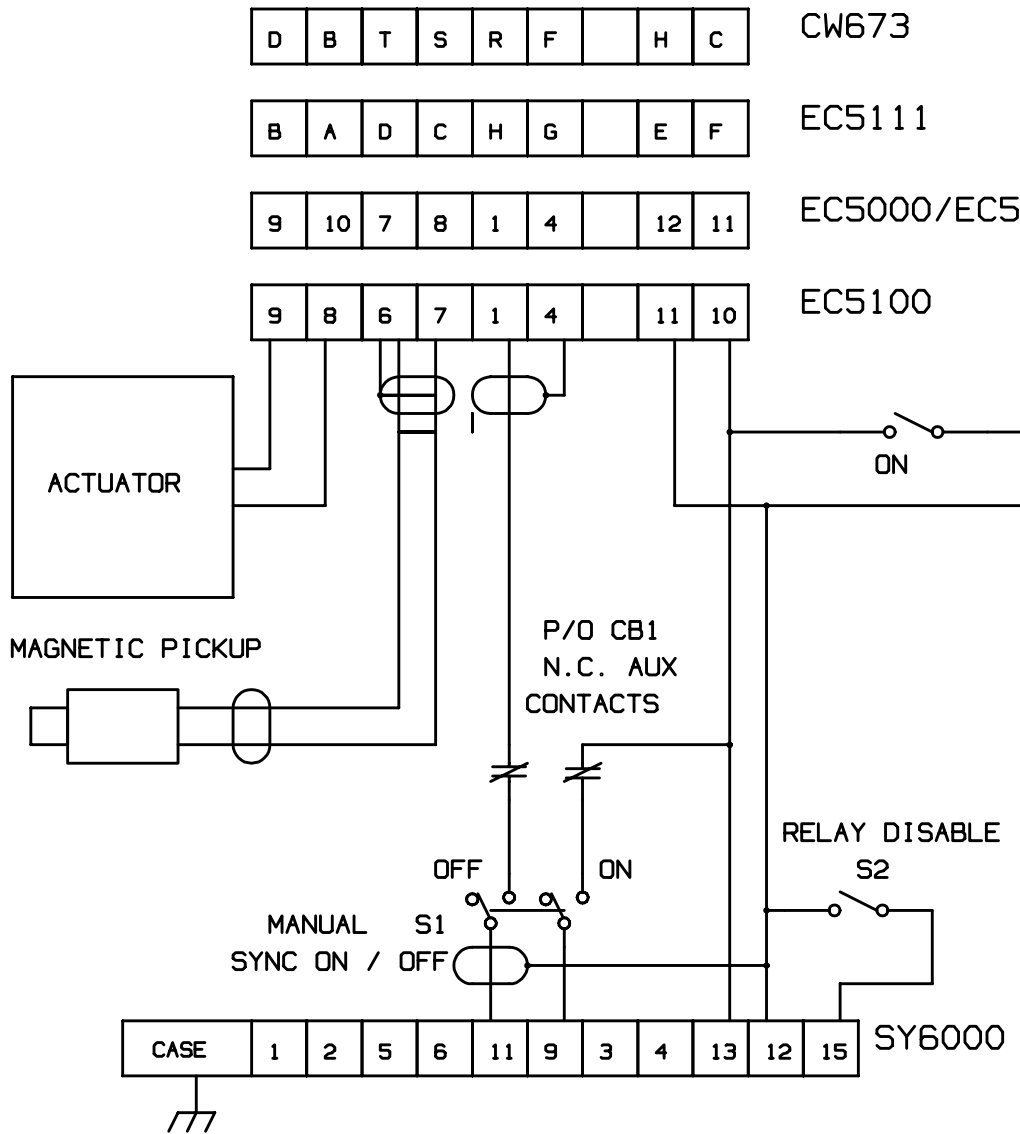

Figure 2. Connection to AMBAC Speed Controllers

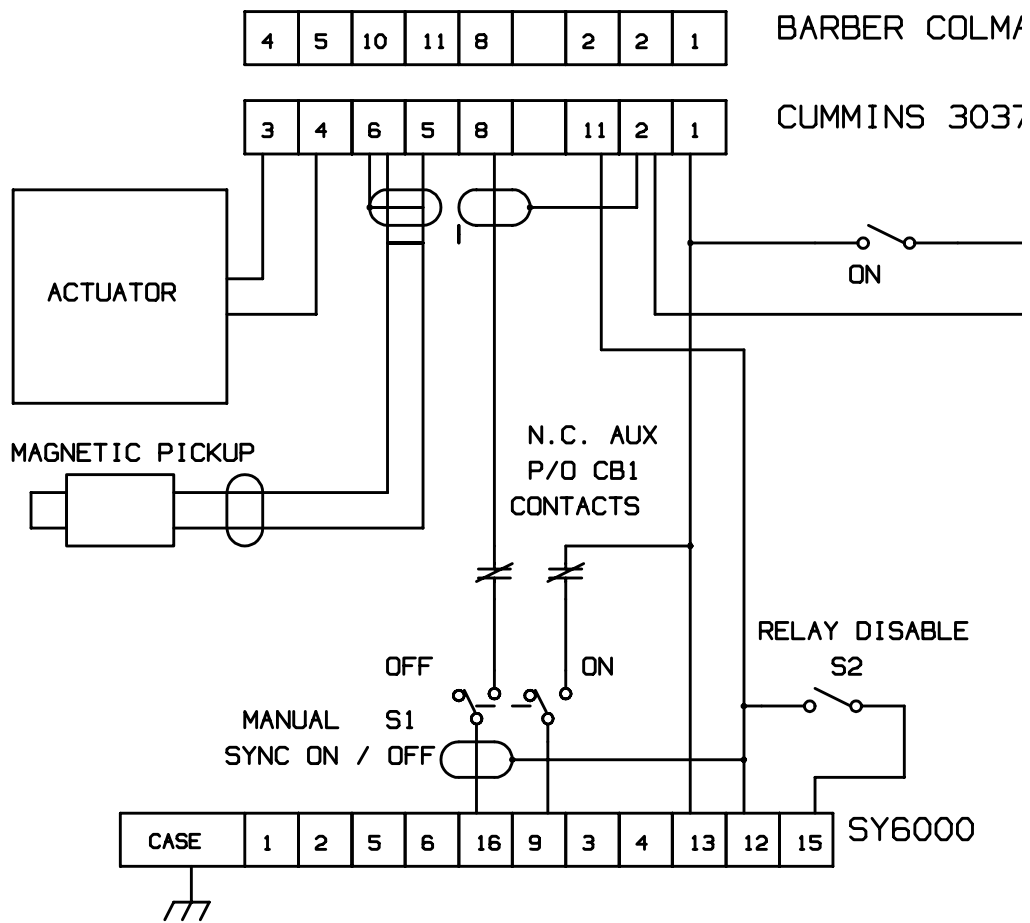

Figure 3. Connection to Cummins or Barber Colman Speed Controllers