

APF

1CQ

Supersedes Section D 195/100, Issued March, 1970

SERVICE PARTS LIST
And
CALIBRATION SPECIFICATIONS
For
AMERICAN BOSCH
APF 1CQ - - - T EXECUTION
FUEL INJECTION PUMPS
(USED ON ALCO PRODUCTS ENGINES)



SYMBOLS

- | | |
|---------------------------------------|---|
| • - New Part | ** - Not Illustrated |
| † - Discontinued with no replacement. | *** - Not Shown Assembled |
| * - Parts Included in listed kit. | - Text or listing opposite has been revised or changed. |

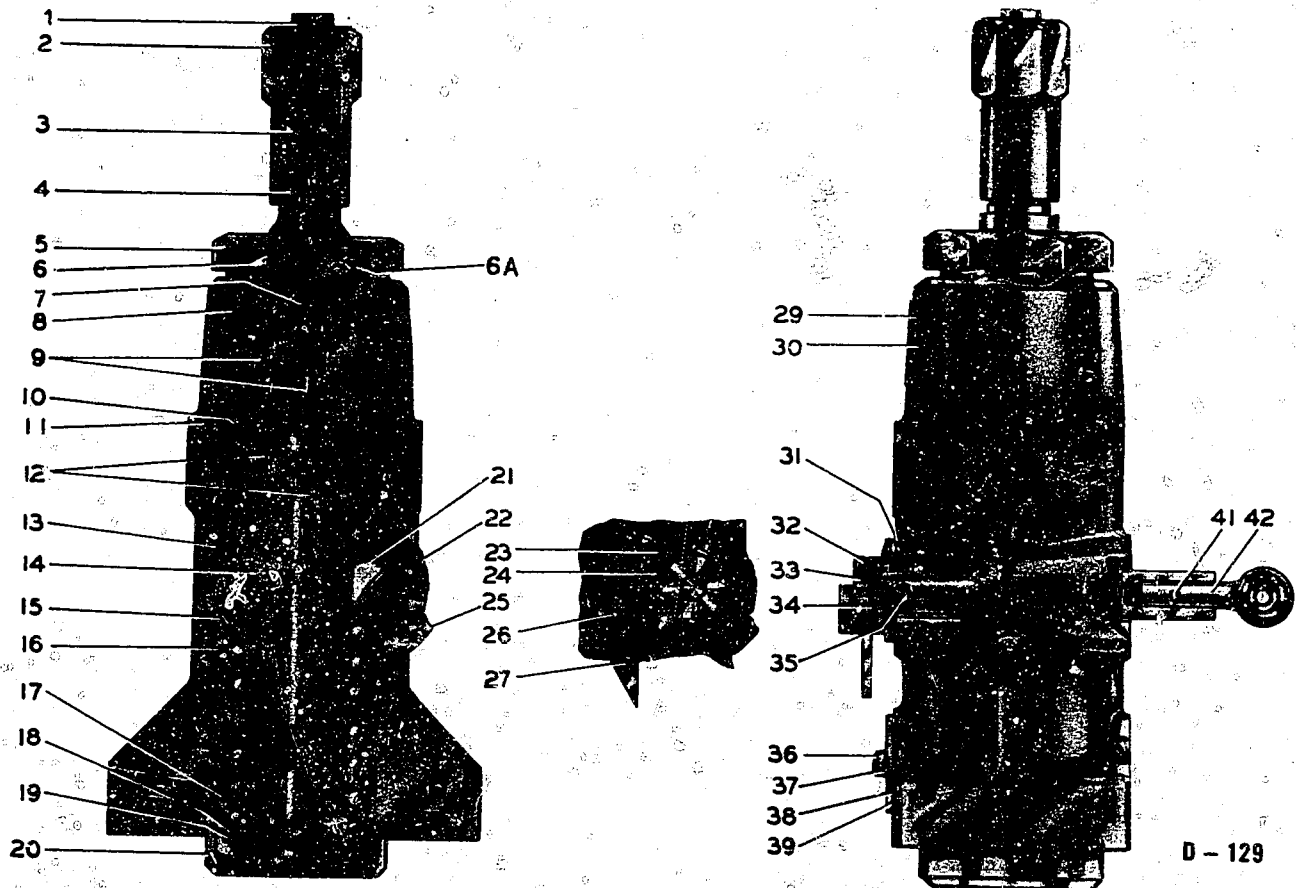

NOTE: (1) Unless otherwise indicated in parenthesis () following description of part, quantity used is one - applicable to all lists. (2) For explanation of abbreviations, refer to Section D 10/20. (3) The first digit of an "Ill. No." identifies the applicable figure; the numbers following the dash (-) refer to the illustrated parts in the figure.

BASIC SERVICE PARTS LIST

Ill. No.	Part No.	Description	Ill. No.	Part No.	Description
1-1	See Note 1	WASHER, union nut	1-33	AS 766	STOP, adjustable - See Note 4
1-2	See Note 1	NUT, union	1-34	SR 7630-1	SHIM, adjng stop - .005" (AR)
1-3	VA 76194A	VALVE ASSY, sbr		SR 7630-2	SHIM, adjng stop - .0075" (AR)
1-4	HP 76356	HOLDER, dely va		SR 7630-3	SHIM, adjng stop - .010" (AR)
1-5	NT 7668	NUT, scurng-torque to 450-500 lbs. ft. (600-670 Nm)		SR 7630-4	SHIM, adjng stop - .020" (AR)
1-6	RG 1047	RING, backup - leather		SR 7630-5	SHIM, adjng stop - .031" (AR)
1-6A	GA 76214	GASKET, "O" ring		PN 11c2	PIN, securing stop - See Note 4
1-7	SP 76114	SPRING, dely va	1-35	SC 28-10CA	SCREW, fstng-insptn in cv(2)
1-8	GA 1060	GASKET, "O" ring	1-37	GA 7616	GASKET, fstng sc (2)
1-9	VA 76196A	VALVE ASSY, dely	1-38	GA 76269	GASKET, cv - insptn wn
1-10	BA 762	BAFFLE, ring	1-39	CV 76293	COVER, ins. wn
1-11	HG 761142A	HOUSING ASSY, pump - incl 1-13 & 1-21	1-40	Deleted	
**a	See Note 1	SCREW, fuel inlet	1-41	PN 1162	PIN, securing cntl rack lk - See Note 5
**b	See Note 1	GASKET, fuel inlet sc (2)	1-42	LN 765	LINK, cntl rack - See Note 5
1-12	BC 76286-2A	PLUNGER & BBL ASSY			
1-13	PN 7652	PIN, bbl lctng - See Note 2			
1-14	SV 7656	SLEEVE, control			
1-15	GU 76144	SEAT, sp - upper			
1-16	SP 76141	SPRING, plunger			
1-17	GU 76153	GUIDE, cup			
1-18	WA 7646	WASHER, plain			
1-19	GU 76114	SEAT, sp - lower			
1-20	RG 7624	RING, snap			
1-21	BG 7678	BUSHING cntl rack (2) - See Note 3			
1-22	Wi 763	WIRE, lock (AR)			
1-23	SC 60-8 CA	SCREW, fstng - po (2)			
1-24	PO 7610	POINTER			
1-25	SC 76179	SCREW, stop			
1-26	SC 76178	SCREW, fstng - latch			
1-27	LH 762	LATCH ASSY			
1-28	Deleted				
1-29	NP 7659	NAMEPLATE, field service			
1-30	SC 150-2	SCREW, dv - np (2)			
1-31	SR 7629-1	SHIM, adjng po - .005" (AR)			
	SR 7629-2	SHIM, adjng po - .0075" (AR)			
	SR 7629-3	SHIM, adjng po - .010" (AR)			
	SR 7629-4	SHIM, adjng po - .020" (AR)			
	SR 7629-5	SHIM, adjng po - .031" (AR)			
	SR 7629-6	SHIM, adjng po - .062" (AR)			
	SR 7629-7	SHIM, adjng po - .078" (AR)			
	SR 7629-8	SHIM, adjng po - .093" (AR)			
1-32	RD 76205A	RACK ASSY, cntl - incl 1-33, 1-34, 1-35, 1-41 & 1-42 - See Notes 4 & 5			

NOTES

- Parts not supplied by American Bosch must be obtained from:
ALCO Power Inc.
100 Orchard Street
Auburn, N. Y. 13021
- IMPORTANT:** These parts are not furnished by American Bosch on service replacement pumps.
- Using a .375" (9.52mm) diameter rod and an arbor press, press barrel locating pin (1-13) into housing until rod bottoms in counterbore of housing.
- When replacing control rack bushings (1-21), install and ream with service tool reamer TSE 76152.
- Adjust stop (1-33) so that face will coincide with rack graduation mark "34" using shims (1-34). Drill hole .156" - .158" (#22 drill) through stop (1-33) and secure with pin (1-35).
- Position control rack link (1-42) so that flat on link is parallel with tooth pitch line and center of link hole is 3.373" - 3.377" (85.68 - 85.78mm) from centerline of center tooth space of control rack. Drill hole .156" - .158" (#22 drill) through control rack link (1-42) and secure with pin (1-41).

VARIATIONS

NOTE: The following parts lists itemize particular parts and/or quantities that apply to variations of the basic pump.

APF 1CQ 160T 3568A

(ALCO #2320012-4 & -5)

ALCO Engine - Model 251A

Timed for port closing. Scribe timing mark on window 1.047" - 1.055" (26.6 - 26.8mm) above bottom face of mounting flange.

Ill. No.	Part No.	Description
1-3	+ VA 76180A	VALVE ASSY, snubber
1-4	+ HP 76273A	HOLDER, dely va
1-5	+ SP 7671	SPRING, dely va
1-9	+ VA 76181A	VALVE ASSY, dely
1-11	+ HG 761117A	HOUSING, pump - incl 1-13 & 1-21
1-12	+ BC 76271-3A	PLUNGER & BBL ASSY
1-18	+ WA 7643	WASHER, plain
1-19	+ SQ 76109	SEAT, spring - lower
1-32	+ RD 76197A	RACK ASSY, cntl - incl 1-33, 1-34, 1-35, 1-41 & 1-42 - See Note 5 on Basic Parts List & Note 6
1-33	+ AF 765	STOP, adjustable

Refer to Basic Parts List, Section D195/100, for all other required parts.

NOTES

- Adjust stop (1-33) so that face will coincide with rack graduation mark "30" using shims (1-34). Drill hole .156" - .158" (#22 drill) through stop (1-33) and secure with pin (1-35).

CALIBRATION

- Use TSE 8410 (1.25mm orifice) full load, TSE 8411 (0.5mm orifice) idle and 5/16" x .123" x 21" (7.94mm x 3.12mm x 533.4mm) long high pressure tubing.
- Set at 500 RPM and control rack position of 30mm for 365 - 370 cc/300 strokes.
- Check at 175 RPM and control rack position of 10mm for 31 - 35 cc/300 strokes.

APF 1CQ 150T 3730A & B

(ALCO #2320014)

ALCO Engine - Model 251A

Timed for port closing. Scribe timing mark on window 1.051" - 1.059" (26.7 - 26.9mm) above bottom face of mounting flange.

Ill. No.	Part No.	Description
1-3	+ VA 76180A	VALVE ASSY, snbr
1-9	+ VA 76189A	VALVE ASSY, dely
1-11	+ HG 761117A	HOUSING, pump - incl 1-13 & 1-21
1-12	+ BC 76297-2A	PLUNGER & BBL ASSY
1-32	+ RD 76199A	RACK ASSY, cntl - incl 1-33, 1-34, 1-35, 1-41 & 1-42 - See Note 5 on Basic Parts List & Note 7

CAUTION: On APF 1CQ 150T 3730A, if plunger and barrel assembly (1-12), washer (1-18) or lower spring seat (1-19) must be replaced, all three components must be replaced at one time and the part number must be changed to APF 1CQ 150T 3730B.

Refer to Basic Parts List, Section D195/100 for all other required parts.

NOTES

- Adjust stop (1-33) so that face will coincide with rack graduation mark "32" using shims (1-34). Drill hole .156" - .158" (#22 drill) through stop (1-33) and secure with pin (1-35).

CALIBRATION

- Use TSE 8410 (1.25mm orifice) full load, TSE 8411 (0.5mm orifice) idle and 5/16" x .123" x 21" (7.94 mm x 3.12mm x 533.4mm) long high pressure tubing.
- Set at 500 RPM and control rack position of 32mm for 375 - 385 cc/300 strokes.
- Check at 175 RPM and control rack position of 8mm for 20 - 23 cc/300 strokes.

APF 1CQ 150T 4016A thru H

(ALCO #2320016-3)

ALCO Engine - Model 251B

Timed for port closing. Scribe timing mark on left side of window only .996" - 1.004" (25.3 - 25.5mm) above bottom face of mounting flange.

Refer to Basic Parts List, Section D195/100 for all required parts and notes.

CALIBRATION

1. Use TSE 8410 (1.25mm orifice) full load, TSE 8411 (0.5mm orifice) idle and 5/16" x .123" x 21" (7.94mm x 3.12mm x 533.4mm) long high pressure tubing.
2. Set at 500 RPM and control rack position of 30mm for 343 - 353 cc/300 strokes.
3. Check at 175 RPM and control rack position of 9mm for 30 - 34 cc/300 strokes.

APF 1CQ 150T 4561A

(ALCO #23200116-2 & 23200120-1)

ALCO Engine - Model 251B

Timed for port closing. Scribe timing mark on left side of window only .996" - 1.004" (25.3 - 25.5mm) above bottom face of mounting flange.

Ill. No.	Part No.	Description
1-3	VA 76202A	VALVE ASSY, snbr
1-7	SP 76119	SPRING, dely valve
1-9	VA 76201A	VALVE ASSY, dely
1-12	BC 76321-2A	PLUNGER & BBL ASSY

Refer to Basic Parts List, Section D195/100, for all other required parts.

CALIBRATION

1. Use TSE 8410 (1.25mm orifice) full load, TSE 8411 (0.5mm orifice) idle and 5/16" x .123" x 21" (7.94 mm x 3.12mm x 533.2mm) long high pressure tubing.
2. Set at 500 RPM and control rack position of 30mm for 343 - 353 cc/300 strokes.
3. Check at 175 RPM and control rack position of 9mm for 30 - 34 cc/300 strokes.

APF 1CQ 170T 5048A thru E

(ALCO #4320021 & 4320021-1)

ALCO Engine - Model 251D, E & F

Timed for port closing. Scribe timing mark on left side of window only .996" - 1.004" (25.3 - 25.5mm) above bottom face of mounting flange.

Ill. No.	Part No.	Description
1-9	VA 76189A	VALVE ASSY, dely
1-12	BC 76356A	PLUNGER & BBL ASSY

CAUTION: A minimum of .020" (0.5mm) spacers (1-31) must be used under pointer (1-24).

Refer to Basic Parts List, Section D195/100, for all other required parts.

CALIBRATION

1. Use TSE 8410 (1.25mm orifice) full load, TSE 8411 (0.5mm orifice) idle and 5/16" x .123" x 21" (7.94mm x 3.12mm x 533.2mm) long high pressure tubing.
2. Set at 500 RPM and control rack position of 28mm for 395 - 402 cc/300 strokes.
3. Check at 175 RPM and control rack position of 9mm for 43 - 47 cc/300 strokes.

APF 1CQ 160T 5655A thru E

(ALCO #23200123 & 23200123-1)

ALCO Engine - Model 251C

Timed for port closing. Scribe timing mark on left side of window only .996" - 1.004" (25.3 - 25.5mm) above bottom face of mounting flange.

Ill. No.	Part No.	Description
1-12	BC 76286-3A	PLUNGER & BARREL ASSY

Refer to Basic Parts List, Section D195/100, for all other required parts.

CALIBRATION

1. Use TSE 8410 (1.25mm orifice) full load; TSE 8411 (0.5mm orifice) idle and 5/16" x .123" x 21" (7.94mm x 3.12mm x 533.2mm) long high pressure tubing.
2. Set at 525 RPM and control rack position of 32mm for 424 - 429 cc/300 strokes.
3. Check at 200 RPM and control rack position of 8mm for 25 - 29 cc/300 strokes.

APF 1CQ 150T 5687A

(ALCO #23200124)

ALCO Engine - Model 251B

Timed for port closing. Scribe timing mark on left side of window only .996" - 1.004" (25.3 - 25.5mm) above bottom face of mounting flange.

Ill. No.	Part No.	Description
1-12	BC 76286-8A	PLUNGER & BARREL ASSY

Refer to Basic Parts List, Section D195/100, for all other required parts.

CALIBRATION

1. Use TSE 8410 (1.25mm orifice) full load, TSE 8411 (0.5mm orifice) idle and 5/16" x .123" x 21" (7.94mm x 3.12mm x 533.2mm) long high pressure tubing.
2. Set at 500 RPM and control rack position of 30mm for 343 - 353 cc/300 strokes.
3. Check at 175 RPM and control rack position of 9mm for 30 - 34 cc/300 strokes.

APF 1CQ 160T 6325A thru C

(ALCO #23200126 & 23200126-1)

ALCO Engine - Model 251C

Timed for port closing. Scribe timing mark on left side of window only .996" - 1.004" (25.3 - 25.5mm) above bottom face of mounting flange.

Ill. No.	Part No.	Description
1-12	BC 76286-3A	PLUNGER & BBL ASSY
**	ST 761	STOP, latch - See Note

NOTE: Install latch stop on SC 76178 (1-26) beneath latch assembly (1-27) and adjacent to pump housing. Flat of latch stop must butt against rack pointer shims (1-31).

Refer to Basic Parts List, Section D195/100 for all other required parts.

CALIBRATION

1. Use TSE 8410 (1.25mm orifice) full load, TSE 8411 (0.5mm orifice) idle and 5/16" x .123" x 21" (7.94mm x 3.12mm x 533.2mm) long high pressure tubing.
2. Set at 525RPM and control rack position of 32mm for 424 - 429 cc/300 strokes.
3. Check at 200 RPM and control rack position of 8mm for 25 - 29 cc/300 strokes.

APF 1CQ 180T 6445A thru C

(ALCO #23200127)

ALCO Engine - Model 251F

CALIBRATION

Timed for port closing. Scribe timing mark on left side of window only .996" - 1.004" (25.3 - 25.5mm) above bottom face of mounting flange.

Ill. No.	Part No.	Description
1-9	VA 76189A	VALVE ASSY, delivery
1-12	BC 76408-1A	PLUNGER & BBL ASSY

NOTE: A minimum of .020" (0.5mm) spacers (1-31) must be used under the pointer.

Refer to Basic Parts List, Section D195/100, for all other required parts.

1. Use TSE 8410 (1.25mm orifice) full load, TSE 8411 (0.5mm orifice) idle and 5/16" x .123" x 21" (7.94mm x 3.12mm x 533.2mm) long high pressure tubing.

2. Set at 450 RPM and control rack position of 28mm for 335 - 342 cc/200 strokes.

3. Check at 175 RPM and control rack position of 9mm for 28 - 32 cc/200 strokes.

APF 1CQ 170T 6631A

(ALCO #23200134)

ALCO Engine - Model 251F

CALIBRATION

Timed for port closing. Scribe timing mark on left side of window only .996" - 1.004" (25.3 - 25.5mm) above bottom face of mounting flange.

Ill. No.	Part No.	Description
1-9	VA 76189A	VALVE ASSY, dely
1-12	BC 76448-1A	PLUNGER & BBL ASSY
**	SR 7655	SPACER, latch - installed between latch 1-27 and housing (1-11)

NOTE: A minimum of .020" (0.5mm) spacers (1-31) must be used under the pointer.

Refer to Basic Parts List, Section D195/100, for all other required parts.

1. Use TSE 8410 (1.25mm orifice) full load, TSE 8411 (0.5mm orifice) idle and 5/16" x .123" x 21" (7.94mm x 3.12mm x 533.2mm) long high pressure tubing.

2. Set at 550 RPM and control rack position of 32mm for 348 - 351 cc/200 strokes.

3. Check at 200 RPM and control rack position of 9mm for 27 - 30 cc/200 strokes.

Supersedes Manual Pages D192/450 thru /452, Issued April, 1965

SERVICE PARTS LIST
And
CALIBRATION SPECIFICATIONS
For
AMERICAN BOSCH
APF 1CQ --- T EXECUTION
FUEL INJECTION PUMPS
(USED ON WHITE MOTORS ENGINES)



SYMBOLS

- | | |
|---------------------------------------|---|
| • - New Part | .. - Not Illustrated |
| † - Discontinued with no replacement. | ... - Not Shown Assembled |
| • - Parts Included in listed kit. | - Text or listing opposite has been revised or changed. |

NOTE: (1) Unless otherwise indicated in parenthesis () following description of part, quantity used is one - applicable to all lists. (2) For explanation of abbreviations, refer to Section D10/20. (3) The first digit of an "Ill. No." identifies the applicable figure; the numbers following the dash (-) refer to the illustrated parts in the figure.

SERVICE PARTS LIST FOR BASIC APF 1 CQ 180T --- FUEL INJECTION PUMP

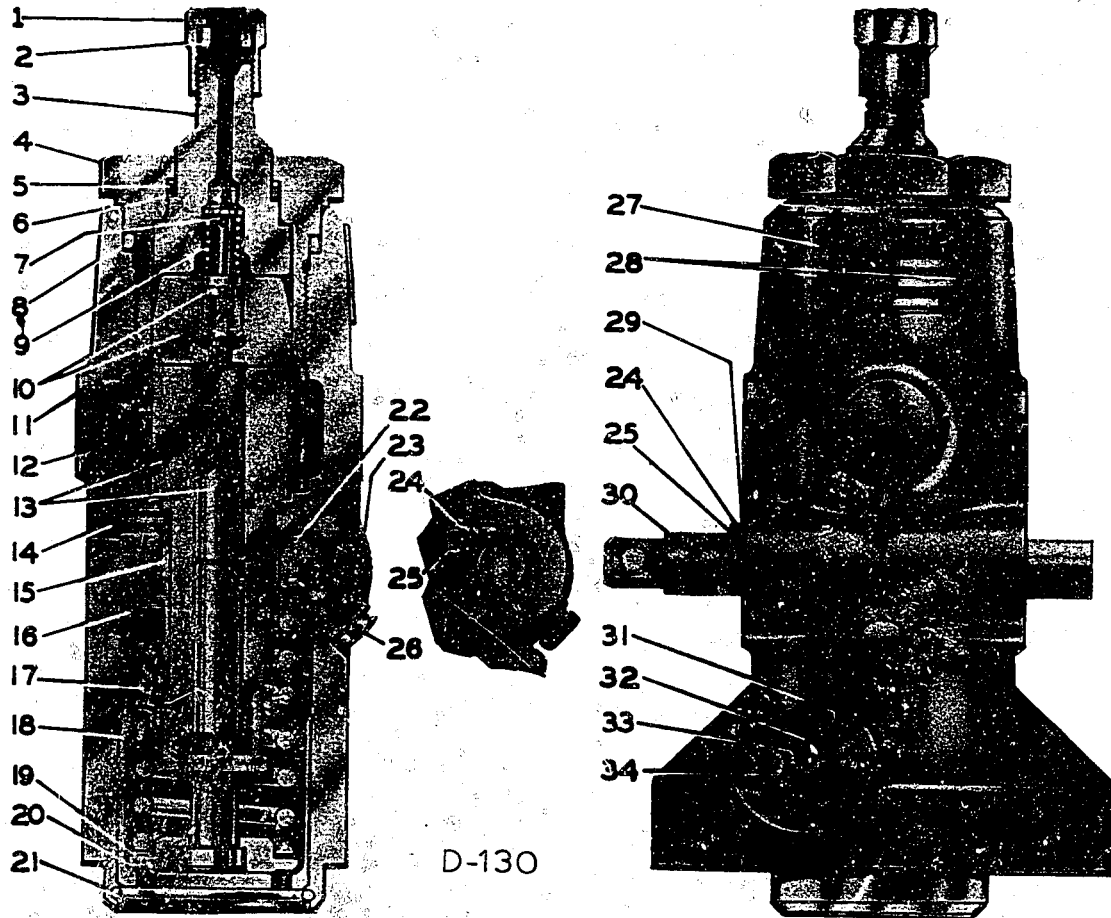

FIGURE 1

Ill. No.	Part Number	Description	Ill. No.	Part Number	Description
1-1	WMU 2089/1X	NUT, union	1-10	VA 76196 A	VALVE ASSY, dely
1-2	WMS 2108/400X	WASHER, union nut	1-11	HG 761179 A	HOUSING, pump - incl 14 & 22
1-3	+ HP 76322 A	HOLDER, dely va - includes 7	1-12	BA 764	BAFFLE, ring
1-4	NT 7668	NUT, securing	1-13	BC 76337-1A	PLUNGER & BARREL ASSY
1-5	RG 1047	RING, backup - leather	1-14	PN 7652	PIN, locating
1-6	GA 76214	GASKET, "O" ring	1-15	SV 7656	SLEEVE, control
1-7	GU 76112	SEAT, sp - See Note 1	1-16	GU 76144	SEAT, sp - upper
1-8	GA 1060	GASKET, "O" ring	1-17	SP 76113	SPRING, plunger
1-9	SP 76114	SPRING, dely va			

AMERICAN BOSCH MARKETING DIVISION**AMBAC**

INDUSTRIES INC

SPRINGFIELD, MASS. 01107

Ill. No.	Part Number	Description
1-18	GJ 76153	GUIDE, cup
1-19	WA 7646	WASHER, plain
1-20	GU 76114	SEAT, spring - lower
1-21	RG 7624	RING, snap
1-22	BG 7678	BUSHING, cntl rack (2) - See Note 2
1-23	WI 763	WIRE, lock (AR)
1-24	PO 768	POINTER
1-25	SC 78-8 CA	SCREW, fstng - po
1-26	SC 76179	SCREW, stop
1-27	NP 7659	NAMEPLATE
1-28	SC 150-2	SCREW, dv - np (2)
1-29	WMS 2040/16X	SHIM, adjng - pointer .008" (AR)
	WMS 2040/17X	SHIM, adjng - pointer .012" (AR)
	WMS 2104/3X	SHIM, adjng - pointer .020" (AR)
	WMS 2104/4X	SHIM, adjng - pointer .065" (AR)
	WMS 2104/5X	SHIM, adjng - pointer .035" (AR)

Ill. No.	Part Number	Description
1-30	RD 76215	RACK, control
1-31	GA 76269	GASKET, cv - insptn window
1-32	CV 76293	COVER, insptn wn
1-33	GA 7616	GASKET, fstng sc (2)
1-34	SC 28-6 CA	SCREW, fstng (2)

NOTES

- To press out spring seat (Ill. 7), use pin 5/32" O.D. x 2" long. To install, use sleeve 23/64" O.D. x 7/32" I.D. x 2" long.
- Use Bacharach tool number 72-0068 (A.B. # TSE 76152) to ream control rack bushings (Ill. 22).

AMERICAN BOSCH MARKETING DIVISION



SPRINGFIELD, MASS. 01107

VARIATIONS

4600	4796
4631	5090

NOTE: The following parts lists itemize particular parts and/or quantities that apply to variations of the basic pump.

APF 1CQ 180T 4600 A & B

WHITE MOTORS ENGINE MODEL 60 SX 8 -
12" x 15"

Time for port closing. Scribe timing mark on window 1.014" - 1.022" above bottom face of mounting flange.

Refer to Basic Parts List, Section D195/101, for all required parts.

CALIBRATION

1. Use TSE 8410 (1.25 mm orifice) full load, TSE 8411 (0.5 mm orifice) idle and 5/16" x .123" x 21" high pressure tubing.
2. Set at 225 RPM and control rack position of 22 mm for 414 - 420 cc/250 strokes.
3. Check at 225 RPM and control rack position of 4 mm for 25 - 29 cc/250 strokes.

APF 1CQ 180T 4631 A & B

WHITE MOTORS ENGINE MODEL 60 SX 8 -
12" x 15"

Time for port closing. Scribe timing mark on window 1.014" - 1.022" above bottom face of mounting flange.

Ill. No.	Part Number	Description
1-9	SP 76135	SPRING, dely valve
1-10	VA 76201 A	VALVE ASSY, dely
1-13	BC 76341-1 A	PLUNGER & BARREL ASSEMBLY

Refer to Basic Parts List, Section D195/101, for all other required parts.

CALIBRATION

1. Use TSE 8410 (1.25 mm orifice) full load, TSE 8411 (0.5 mm orifice) idle and 5/16"

x .123" x 21" high pressure tubing.

2. Set at 225 RPM and control rack position of 22 mm for 414 - 420 cc/250 strokes.
3. Check at 225 RPM and control rack position of 4 mm for 25 - 29 cc/250 strokes.

APF 1CQ 180T 4796A & B

WHITE MOTORS ENGINE MODEL 60 SX 8
(Dual Fuel) - 12" x 15"

Time for port closing. Scribe timing mark on window 1.014" x 1.022" above bottom face of mounting flange.

Ill. No.	Part Number	Description
1-10	+ VA 76217 A	VALVE ASSY, dely
1-13	BC 76345-1 A	PLUNGER & BARREL ASSY

Refer to Basic Parts List, Section D195/101, for all other required parts.

CALIBRATION

1. Use TSE 8410 (1.25 mm orifice) full load, TSE 8411 (0.5 mm orifice) pilot and 5/16" x .123" x 21" high pressure tubing.
2. Set at 225 RPM and control rack position of 3 mm for 19 - 20.5 cc/300 strokes (pilot).
3. Check at 225 RPM and control rack position of 26 mm for 375 - 385 cc/200 strokes (full load).

APF 1CQ 180T 5090A

WHITE MOTORS ENGINE MODEL 60 SX 8 -
12" x 15"

Time for port closing. Scribe timing mark on window 1.014" - 1.022" above bottom face of mounting flange.

- Cont'd -

AMERICAN BOSCH MARKETING DIVISION**AMBAC**

INDUSTRIES INC.

SPRINGFIELD, MASS. 01107**5091A
5092A**

Ill. No.	Part Number	Description
1-1	NT 7669	NUT, union
1-2	WA 7648	WASHER, union nut
1-3	HP 76356	HOLDER, dely valve
**	VA 76180A	VALVE ASSY, snbr - must be secured from engine mfr

Refer to Basic Parts List, Section D195/101, for all other required parts.

CALIBRATION

- Use TSE 8410 (1.25 mm orifice) full load, TSE 8411 (0.5 mm orifice) low idle & pilot and 5/16" x .123" x 21" high pressure tubing.
- Set at 225 RPM and control rack position of 22 mm for 414 - 420 cc/250 strokes.
- Check at 225 RPM and control rack position of 4 mm for 25 - 29 cc/250 strokes.

APF 1CQ 180T 5091A

WHITE MOTORS ENGINE MODEL 60 SX 8 -
12" x 15"

Time for port closing. Scribe timing mark on window 1.014" - 1.022" above bottom face of mounting flange.

Ill. No.	Part Number	Description
1-1	NT 7669	NUT, union
1-2	WA 7648	WASHER, union nut
1-3	HP 76356	HOLDER, dely valve
1-9	SP 76135	SPRING, dely valve
1-10	VA 76201A	VALVE ASSY, dely
1-12	BC 76341-1A	PLUNGER & BARREL ASSEMBLY
**	VA 76180A	VALVE ASSY, snbr - must be secured from engine mfr

Refer to Basic Parts List, Section D195/101, for all other required parts.

CALIBRATION

- Use TSE 8410 (1.25 mm orifice) full load, TSE 8411 (0.5 mm orifice) low idle & pilot and 5/16" x .123" x 21" high pressure tubing.

- Set at 225 RPM and control rack position of 22 mm for 414 - 420 cc/250 strokes.
- Check at 225 RPM and control rack position of 4 mm for 25 - 29 cc/250 strokes.

APF 1CQ 180T 5092A

WHITE MOTORS ENGINE MODEL 60 SX 8
(Dual Fuel) - 12" x 15"

Time for port closing. Scribe timing mark on window 1.022" - 1.026" above bottom face of mounting flange.

Ill. No.	Part Number	Description
1-1	NT 7669	NUT, union
1-2	WA 7648	WASHER, union nut
1-3	HP 76356	HOLDER, dely va
1-12	BC 76345-1A	PLUNGER & BARREL ASSEMBLY
**	VA 76180A	VALVE ASSY, snbr - must be secured from engine mfr

Refer to Basic Parts List, Section D195/101, for all other required parts.

CALIBRATION

- Use TSE 8410 (1.25 mm orifice) full load, TSE 8411 (0.5 mm orifice) pilot and 5/16" x .123" x 21" high pressure tubing.
- Set at 225 RPM and control rack position of 3 mm for 19 - 20.5 cc/300 strokes (pilot).
- Check at 225 RPM and control rack position of 26 mm for 280 - 390 cc/200 strokes (full load).