

PSM

**TORQUE
VALUES**

SECTION 11

TORQUE CHART

TORQUE VALUES FOR TMD TYPE TIMING DEVICE

NOTE: Numbers In Parentheses Refer To Illustration Numbers In Figure 3-1, Page 44.

| <u>DESCRIPTION OF PART</u> | <u>TORQUE</u> |
|-----------------------------------|-------------------|
| SCREW, Set - Camshaft Nut (11) | 15 - 18 Lb. Ft. |
| NUT, Camshaft (9) | 50 - 55 Lb. Ft. |
| SCREW, Timing Window Cover (25) | 50 - 60 Lb. In. |
| SCREW, Timing Device Mounting (1) | 17 - 20 Lb. Ft. |
| SCREW, Timing Device Mounting (4) | 17 - 20 Lb. Ft. |
| WEIGHT PIN RETAINING SCREW (20) | 100 - 110 Lb. In. |

TORQUE VALUES FOR TME TYPE TIMING DEVICE

NOTE: Numbers In Parentheses Refer To Illustration Numbers In Figure 2-1, Page 39.

| <u>DESCRIPTION OF PART</u> | <u>TORQUE</u> |
|---------------------------------------|-------------------|
| SCREW, Set - Camshaft Nut (27) | 15 - 18 Lb. Ft. |
| NUT, Camshaft (26) | 50 - 55 Lb. Ft. |
| SCREW, Timing Window Cover (9) | 15 - 20 Lb. In. |
| SCREW, Coupling To Hub Fastening (18) | 17 - 20 Lb. Ft. |
| NUT, Timing Device Mounting (1) | 17 - 20 Lb. Ft. |
| WEIGHT PIN RETAINING SCREW (11C) | 100 - 110 Lb. In. |

PSM-TYPE PUMP TORQUE VALUES

NOTE: TORQUE AUXILIARY LUBE INLET PLUG (OPPOSITE CONTROL UNIT COVER) TO 15-17 LB. FT.

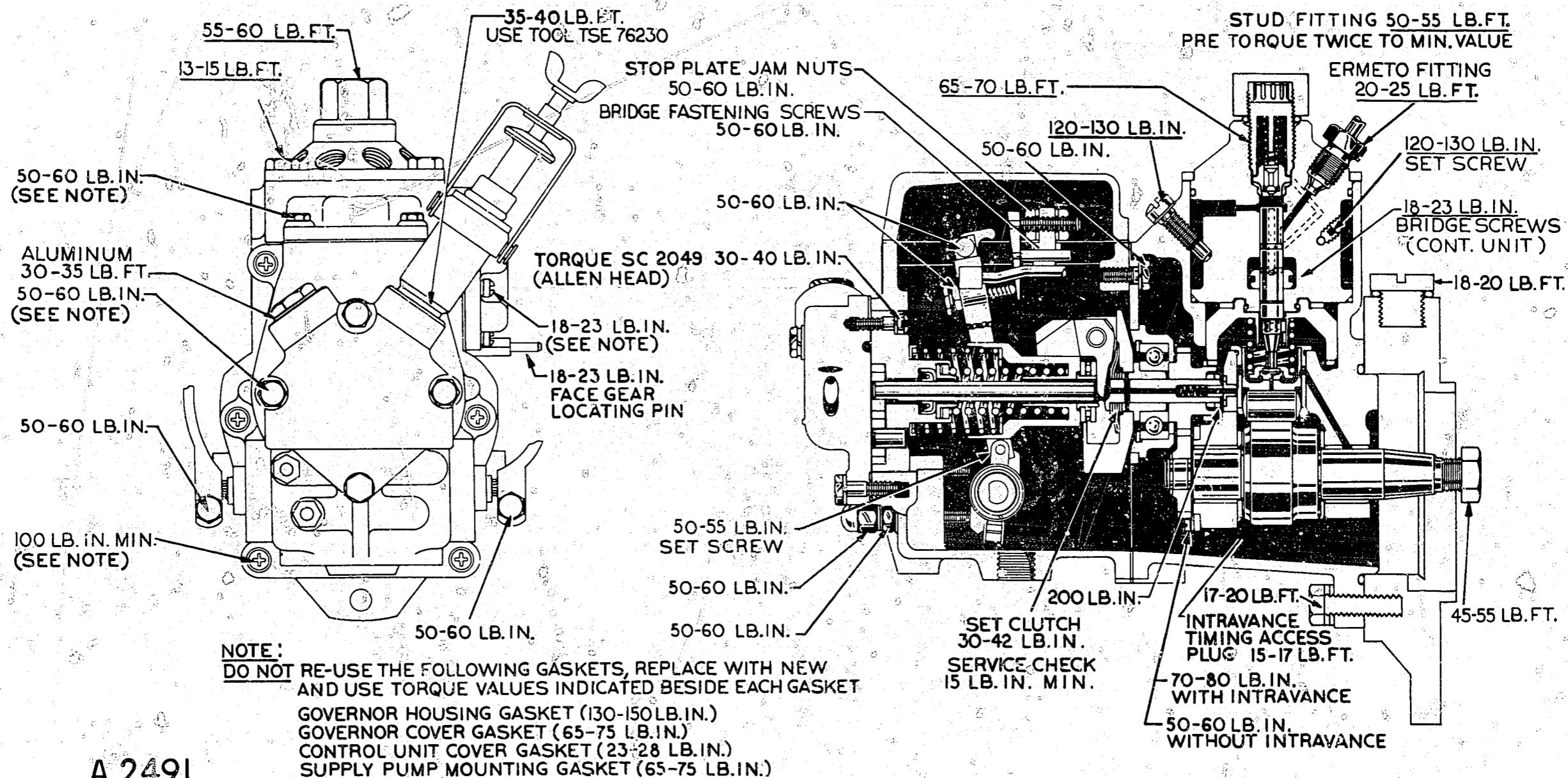

A 2491

UNDERLINED TORQUES ARE MOST IMPORTANT

SERVICE INSTRUCTIONS FOR PSM FUEL INJECTION PUMPS (Supplement)

SUBJECT: CALIBRATION INSTRUCTIONS

CALIBRATION STAND:

IMPORTANT: Use diesel fuel #2, ESSO #260, VISCOR calibrating fluid #1487C or equivalent, heated to 100° - 105° F., or GULF #45 calibrating oil heated to 110° - 115° F.

NOTE: Make certain lube oil supply pressure to pump is at required value before making any checks or adjustments to the pump.

CALIBRATION:

NOTE: Unless otherwise noted, all fuel delivery specifications are given in cubic centimeters (cc) per 500 strokes. Since one (1) cubic centimeter (cc) is equal to one (1) milliliter (ml), burettes graduated in ml's are equivalent to those graduated in cc's.

"SERVICE CHECK SECTION": Use only to check pump as received from customer or factory.

"RECALIBRATION SECTION": Use only to recalibrate the pump - DOES NOT APPLY if pump is within the "Service Check" specifications.

STARTING FUEL CHECK:

If the full load and droop screw check points are within fuel delivery specifications when checking the pump, but the starting fuel delivery is NOT, proceed as follows:

1. Disconnect the control rod from the control unit lever. Hold the control lever in the maximum delivery position, and record fuel delivery at full load speed.
2. Reduce the test stand speed to the starting fuel R.P.M. and record delivery.
3. If starting fuel delivery is at least 50% of maximum fuel delivery, connect the control rod to the control unit lever, recheck all governor settings, and recalibrate pump if necessary.
4. If starting fuel delivery is less than 50% of maximum fuel delivery, proceed as follows:
 - a. Replace delivery valve assembly and/or gasket and spacer.
 - b. Check plunger lift to port closing - for specifications and procedures, refer to Manual Section D 231/1002, Pages 54 through 57.
 - c. Repeat steps 1, 2 and 3.
5. If the foregoing procedures do not yield the required minimum starting fuel delivery, replace the hydraulic head assembly.

TORQUE CAM ANGLE SETTINGS:

NOTE: Refer to "Cam Nose Angle" Column or Note in "CALIBRATION DATA" for a specific pump to obtain required angle setting.

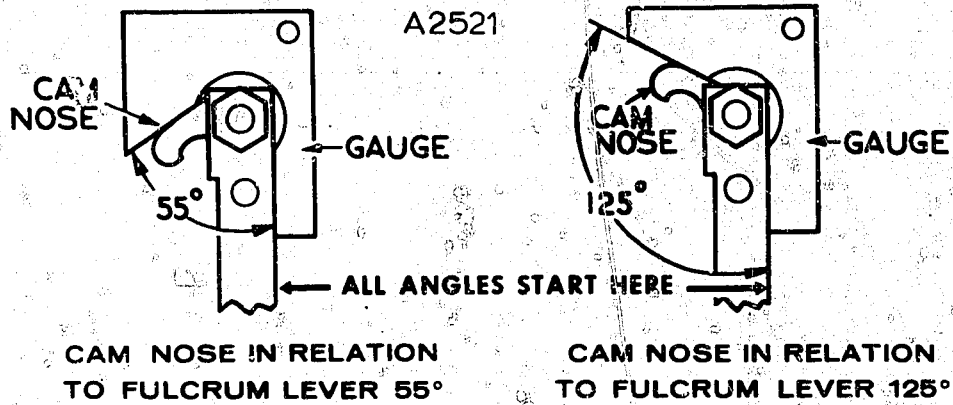

FIGURE 1

AMERICAN BOSCH MARKETING DIVISION / **AMERICAN BOSCH ARMA CORPORATION** / **SPRINGFIELD, MASS. 01107**

SERVICE BULLETIN

SUBJECT: TIMING ADVANCE LIMITS.

PRODUCT AFFECTED: ALL PSJ and PSM PUMPS.

PUBLICATIONS AFFECTED: NONE.

REASON FOR BULLETIN: To provide instructions and advance limits for American Bosch Timing Devices.

INSTRUCTIONS: 1. The following advance limits are released for use with the Bacharach Automatic Advance Indicator (Bacharach No. 67-7043). Refer to Bacharach Form No. 679018 for operating and maintenance instructions.

2. Intravance [®] Advance Limits are as follows:

| <u>Intravance (Part Number)</u> | <u>1 Advance must not start below:</u> | <u>2 Advance Limits (Degrees at R. P. M.)</u> |
|--|--|---|
| CT 8517 A CT 8521 A CT 8523 A CT 8524 A CT 8529 A CT 8530 A | 700 R. P. M. | 10° - 13° at 3200 R. P. M. |
| CT 8520 A | 700 R. P. M. | 10° - 13° at 2100 R. P. M. |
| CT 8526 A CT 8535 A | 700 R. P. M. | 6° - 9° at 2500 R. P. M. |
| CT 8527 A | 700 R. P. M. | 7° - 10° at 2100 R. P. M. |
| CT 8551 A | 600 R. P. M. | 10° - 13° at 2400 R. P. M. |

3. External Timing Device Advance Limits are as follows:

| <u>External Timing Device (Part Number)</u> | <u>1 Advance must not start below:</u> | <u>2 Advance Limits (Degrees at R. P. M.)</u> |
|---|--|---|
| TMD 9B 8378 B 1 TMD 9B 8378 C 1 | 800 R. P. M. | 7° - 10° at 2100 R. P. M. |
| TMD 9B 8378 B 2 TMD 9B 8378 C 2 | 800 R. P. M. | 7° - 10° at 2600 R. P. M. |
| TME 8B 2 | 600 R. P. M. | 7° - 10° at 2300 R. P. M. |
| TME 10B 2 | 600 R. P. M. | 9° - 12° at 2300 R. P. M. |
| TME 17A 2 TME 17B 2 | 600 R. P. M. | 15° - 18° at 2300 R. P. M. |

- Continued -

INSTRUCTIONS: - Continued -

3. Continued -

| <u>External Timing Device (Part Number)</u> | <u>1 Advance must not start below:</u> | <u>2 Advance Limits (Degrees at R.P.M.)</u> |
|---|--|---|
| TMF 17A 1 | 600 R.P.M. | 15° - 18° at 3200 R.P.M. |
| TMF 17A 2 | | |

4. Timing advance should be checked as follows:

- a. Take a reading from the test stand degree wheel at 400 R.P.M. and record.
- b. Increase speed to that given in column 1 for applicable timing device and check to make certain that no advance has occurred.
- c. Increase speed to that given in column 2 for applicable timing device and check to make certain that advance is between limits given.
- d. Observe degree wheel while increasing speed from step b. to step c. to make certain that timing device advances gradually and operation is smooth.

SERVICE BULLETIN

SUBJECT: Tappet Guide Button Pad Wear Limits

PRODUCT AFFECTED: PSJ/PSM Fuel Injection Pumps

REASON FOR BULLETIN: To provide instructions for determining when a tappet guide button pad is worn sufficiently to require replacement.

INSTRUCTIONS:

1. Measure diameter of 1" long x 1/4" (approx.) dia. piece of drill rod with a micrometer.
2. With drill rod assembled to tappet roller bushing, measure distance between drill rod and tappet pad ("A & B" in Figure 1). Make certain that micrometer does not contact center of button pad which is a "No Wear" point.

NOTE: The lube oil drain hole through the button pad will not necessarily be located in the exact center of the pad. This is acceptable because the button slot will still allow lube oil flow.

3. Subtract drill rod diameter from dimension obtained in paragraph 2. Should resulting dimension ("A" in Figure 1) be less than .158", replace tappet guide.

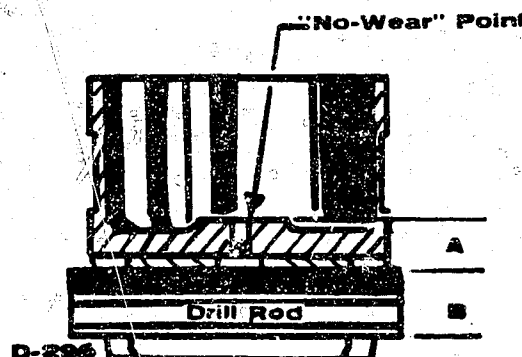

Figure 1

SERVICE BULLETIN

SUBJECT: SGD Supply Pumps

1. SGD 15B--- supply pumps are the current replacements for SGD 15A--- supply pumps. However, the governor housing's supply pump bore must be modified as indicated in Figure 1 to accommodate the GA 1149 "O" ring gasket that must be installed between the SGD 15B--- and governor housing.

CAUTION: A SGD 15A--- can not be applied to a pump with a modified supply pump bore.

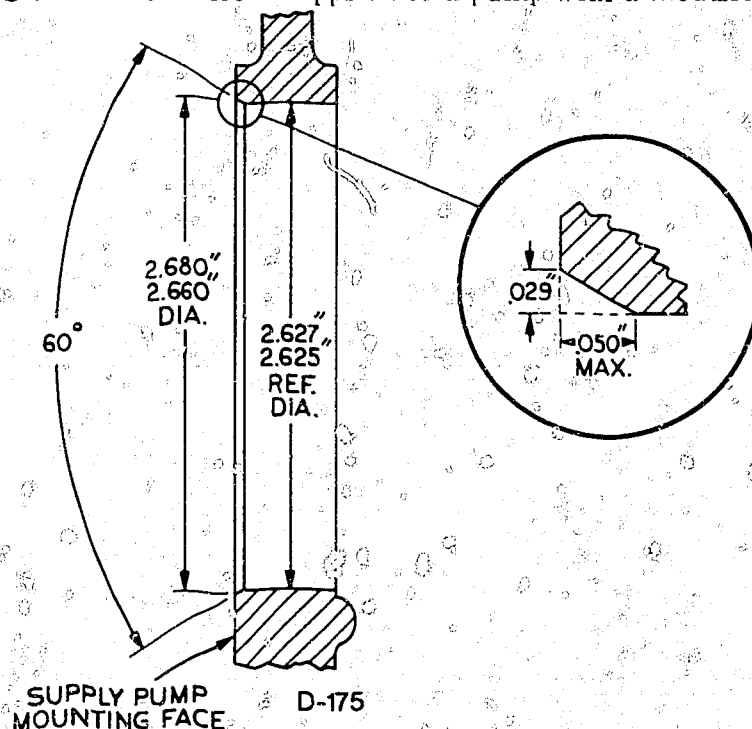

FIGURE 1 - MODIFIED SUPPLY PUMP BORE IN GOVERNOR HOUSING

NOTE: Remove all burrs and sharp edges to prevent damage to the "O" ring gasket.

2. When replacing a SGD 15B--- supply pump insert assembly, utilize the following assemblies:

SUPPLY PUMP

INSERT ASSEMBLY

Clockwise Rotation

SGD 15B 51

IT 8513A

SGD 15B 311

IT 8513A

Counter-Clockwise Rotation

SGD 15B 61

IT 8514A

SGD 15B 411

IT 8514A

3. A GA 8513 shim gasket must NOT be used with an insert assembly that has a figure "8" stamped on the rear face of the insert or an insufficient fuel supply suction will result. The gears on inserts with a stamped "8" are flush with the sealing surface. Insert assemblies without a stamped "8" require a GA 8513 shim gasket. Their gears are 0.0002" - 0.0003" below the sealing face.
4. SGD supply pumps applied to Mack engines were equipped with check valves as follows:

| | SGD 15A--- | SGD 15B--- |
|--------------|--------------|--------------|
| SEALING FACE | VA 9014A (2) | VA 9014A (2) |
| INLET HOLE | VA 9014A (1) | VA 9013A (1) |
| OUTLET HOLE | VA 9014A (1) | VA 9013A (1) |

Supply pumps applied to GMC engines were not equipped with check valves.

5. When installing a SGB 15B--- supply pump, apply a film of grease, LU 3003, to the GA 1149 "O" ring gasket and the supply pump bore in the governor housing.